

Chemtech Scientific provides access to this content as a courtesy.
We do not own the content contained in this document.
All rights and credit go directly to its rightful owners.
www.chemtechsci.com
Call us at: 484-424-9415



TRIVAC NT 5 / NT 10

Operating Instructions 17200918_002_A1

P/N

140 212

140 213

140 214

140 216

140 312

140 313

140 314

140 316

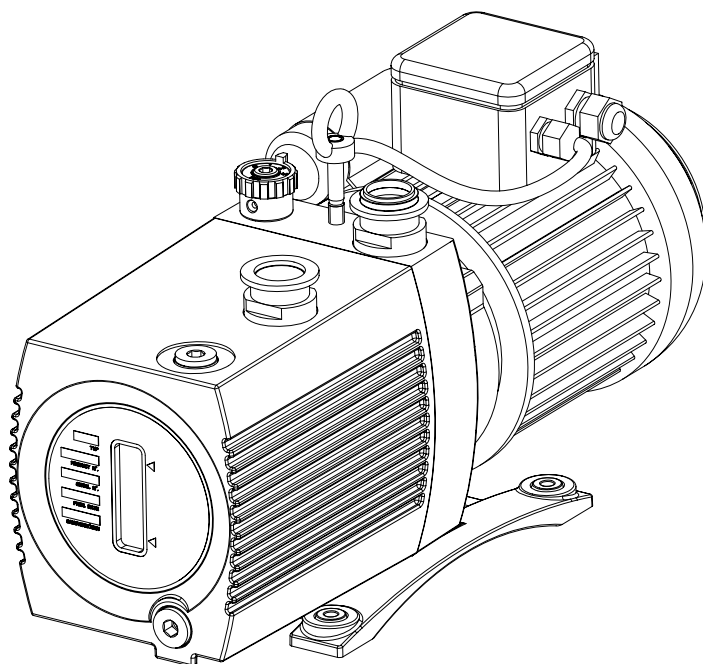

Table of contents

| | Page |
|---|-----------|
| Important Safety Information | 3 |
| 1 Description | 6 |
| 1.1 Principle of Operation | 7 |
| 1.2 Supplied Equipment | 9 |
| 1.2.1 Notes on the Oil and How to Order | 9 |
| 1.3 Technical Data | 10 |
| 1.3.1 Motor Dependent Data | 11 |
| 1.4 Ordering Information | 13 |
| 1.5 Accessories | 13 |
| 2 Transporting and Storing | 14 |
| 3 Installation | 15 |
| 3.1 Placement | 15 |
| 3.2 Conforming Utilisation | 15 |
| 3.3 Connection to the System | 15 |
| 3.4 Electrical Connections | 17 |
| 3.4.1 Pumps with AC motor | 17 |
| 3.4.2 Pumps with Three-Phase Motor | 18 |
| 4 Operation | 19 |
| 4.1 Media Compatibility | 19 |
| 4.2 Start-up | 19 |
| 4.3 Operation | 20 |
| 4.3.1 Pumping of Non-Condensable Gases and Vapours | 20 |
| 4.3.2 Pumping of Condensable Gases and Vapours | 20 |
| 4.3.3 Operating Temperature | 20 |
| 4.4 Shutting Down/Shelving | 21 |
| 5 Maintenance | 22 |
| 5.1 Service at Oerlikon Leybold Vacuum | 22 |
| 5.2 Maintenance Schedule (recommendation) | 23 |
| 5.3 Checking the Oil Level | 24 |
| 5.4 Oil Change | 25 |
| 5.5 Cleaning the Inlet Screen | 26 |
| 5.6 Disassembly and Assembly of the Internal Demister | 27 |
| 5.7 Disassembly and Assembly of the Electric Motor | 27 |
| 6 Troubleshooting | 29 |
| 7 Wearing and Original Parts | 31 |
| 8 Waste Disposal | 31 |
| EC Declaration of Conformity | 32 |

Important Safety Information

Indicates procedures that must be strictly observed to prevent hazards to persons.

Indicates procedures that must strictly be observed to prevent damage to, or destruction of the equipment.

The **TRIVAC NT 5/10** pumps from Oerlikon Leybold Vacuum have been designed for safe and efficient operation when used properly and in accordance with this manual. It is the responsibility of the user to carefully read and strictly observe all safety precautions described in this chapter and throughout the manual. This product must be **operated and maintained by trained personnel only in the proper condition and as described in these Operating Instructions**. Consult local, state, and national agencies regarding specific requirements and regulations. Address any further safety, operation and/or maintenance questions to your nearest Leybold Oerlikon Vacuum office.

Failure to observe the following precautions could result in serious personal injury:

- Before beginning with any maintenance or service work on the TRIVAC NT, disconnect the pump from all power supplies (lockout/tagout).
- Do not operate the pump with any of the covers removed. Serious injury may result.
- If exhaust gases must be collected or contained, do not allow the exhaust line to become pressurised.
- Make sure that the gas flow from the exhaust port is not blocked or restricted in any way.
- The standard version of the TRIVAC NT is not suited for operation in explosion hazard areas.
- Before starting up for the first time, the motor circuit must be equipped with a suitable protective motor switch. Please take note of the information in these Operating Instructions and on the electric motor (wiring diagram).
- The TRIVAC NT pumps including the accessories are fundamentally not suited for pumping of combustible and explosive gases or vapours. Mixtures of substances may, regarding the fire and explosion risk be critical or uncritical. The operating company is under the commitment to analyse this and rate the hazard potential accordingly so as to therefrom derive the necessary safety measures which must be introduced.
- When pumping toxic, chemical, radioactive and corrosive gases as well as pyrophorous substances, the operating company is under the obligation to comply with the national and international safety regulations and guidelines. Regarding the suitability of the TRIVAC NT pumps for special applications in which such gases, respectively substances shall be pumped, Oerlikon Leybold Vacuum should be consulted first.

Warning

Caution

Warning



Safety information

Warning



- Avoid exposing any part of the human body to the vacuum.
- Never operate the TRIVAC NT without a connected intake line or without fitting a blank flange.
- The location at which the TRIVAC NT (including its accessories) is operated should be such that angles over 10° from the vertical are avoided.
- The location of the TRIVAC NT should be such that all controls are easily accessible.
- Under certain ambient conditions the TRIVAC NT may attain a temperature of over 70 °C (158 °F). There then exists the danger of receiving burns. Note the symbols on the pump pointing to the hazards, and in the case of a hot pump wear the required protective clothing.
- All work on the pumps “at operating state temperature“ shall only be done while wearing protective gloves. Always let the pump cool down before any servicing and maintenance work.
- The noise level produced by the TRIVAC NT is 49 dB(A) max. Suitable hearing protection measures must be introduced.
- Before pumping oxygen (or other highly reactive gases) at concentrations exceeding the concentration in the atmosphere (> 21 % for oxygen) it will be necessary to use a special pump. Such a pump will have to be modified and de-greased, and an inert special lubricant (like PFPE) must be used.
- Before operating the TRIVAC NT check first compatibility with the pumped media so as to avoid hazardous conditions during operation right from the start. Observe all applicable safety standards and regulations.
- After a mains power failure the pump will run up automatically again. This also applies in the case of an emergency shutdown. In order to prevent the pump from running up automatically again, the pump must be integrated within a control arrangement such that it can only be switched on manually again after the mains power has returned.
- When operating the pumps at gas throughput, it is urgently recommended to connect an exhaust filter or use a suitable exhaust line. Here, the exhaust line must slope down and away from the pump.
- When moving the TRIVAC NT always use the allowed means. A lifting eye is provided as standard on the pump.
- The pump when filled with oil must only be moved in its vertical position. Spilled oil involves the risk of falling.

Failure to observe the following precautions could result in damage to the pump.

- Do not allow the ingestion of small objects (screws, nuts, washers, pieces of wire, etc.) through the inlet port. Always use the inlet screen which is supplied with every pump.
- Do **not** use the pump for applications that produce abrasive or adhesive powders or condensable vapours that can leave adhesive or high viscosity deposits. Please contact our Sales or Service offices to select a suitable separator. Also please contact Leybold Sales or Service when planning to pump vapours other than water vapour.
- This pump is suited for pumping water vapour within the specified water vapour tolerance limits.
- Avoid vapours that can condense into liquids upon compression inside the pump, if these substances exceed the vapour tolerance of the pump.
- Before pumping vapours, the TRIVAC NT should have attained its operating temperature. The pump will have attained its operating temperature about 30 minutes after starting the pump. During this time the pump should be separated from the process, by a valve in the intake line, for example.
- In the case of wet processes we recommend the installation of liquid separators upstream and downstream of the pump as well as the use of the gas ballast.
- The exhaust line should be laid so that it slopes down and away from the pump so as to prevent condensate from backstreaming into the pump.
- The entry of particles and fluids must be avoided under all circumstances.
- Reactive or aggressive substances in the pump chamber may impair the operating oil or modify it. In addition, such substances may be incompatible with the materials of the pump (Viton, grey cast iron, aluminium, steel, resins, glass etc.).
- Corrosion, deposits and cracking of oil within the pump are not allowed.
- Normal amounts of humidity within the range of the pump's vapour tolerance will not significantly affect pump performance (when the gas ballast is active).
- In the case of custom pumps (with part numbers deviating from those stated in the EC Declaration of Conformity) please note the information provided in the supplementary sheets.

Caution

We reserve the right to modify the design and the specified data. The illustrations are not binding.

Description

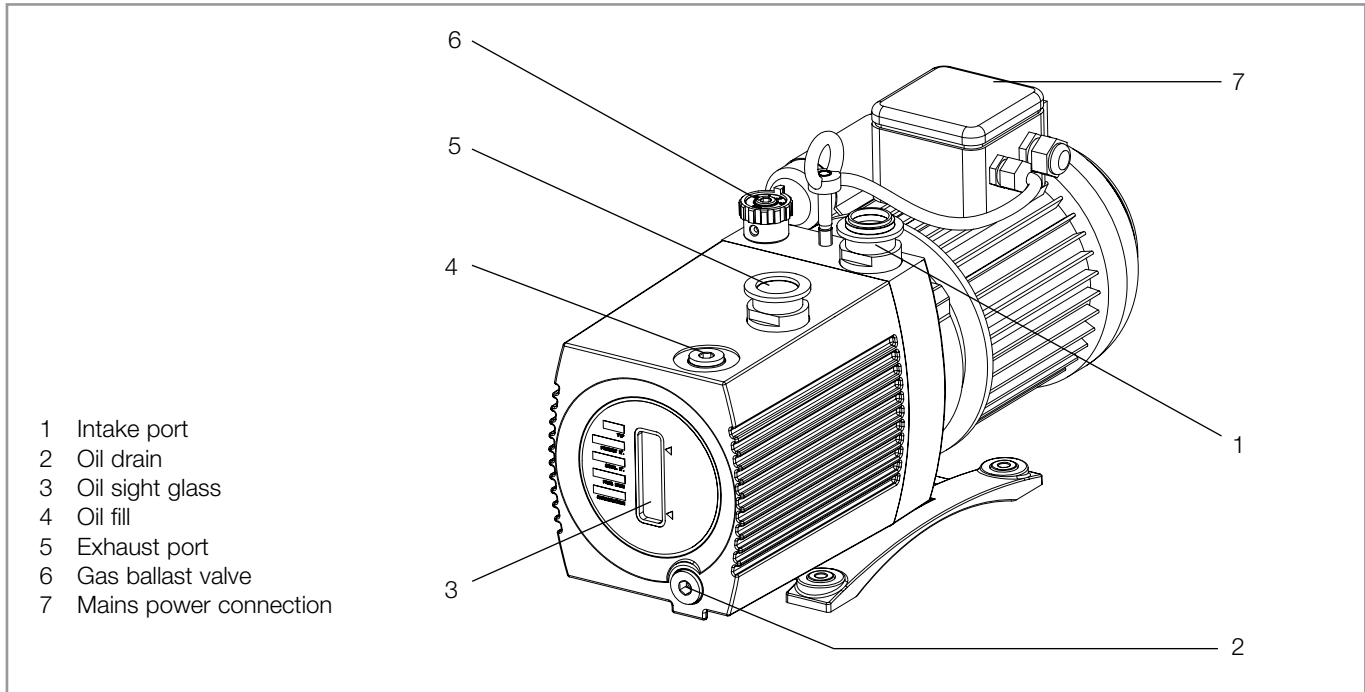

Fig. 1 TRIVAC of the NT series

1 Description

The TRIVAC NT are dual stage oil sealed rotary vane vacuum pumps.

The number in the designation of the pump indicates the pumping speed of this pump in $\text{m}^3 \cdot \text{h}^{-1}$.

These pumps are capable of pumping gases and vapours out of vessels and vacuum systems down into the medium vacuum pressure range. The standard pumps are not designed to handle oxygen at concentrations exceeding the concentration of oxygen in the atmosphere. Moreover, these pumps are not suited for pumping of hazardous gases or extremely aggressive or corrosive media. If in doubt please consult Oerlikon Leybold Vacuum.

The drive motor of the TRIVAC NT is screwed directly to the bearing piece. The shaft of the pump and the shaft of the motor are linked by a coupling piece. The bearings in the inner pump body are force-lubricated sliding bearings.

The oil sight glass for viewing the minimum/maximum oil level and the oil drain as well as the name plate are located on the front of the pump.

The connection components, the gas ballast knob and the oil fill are located on the top of the pump.

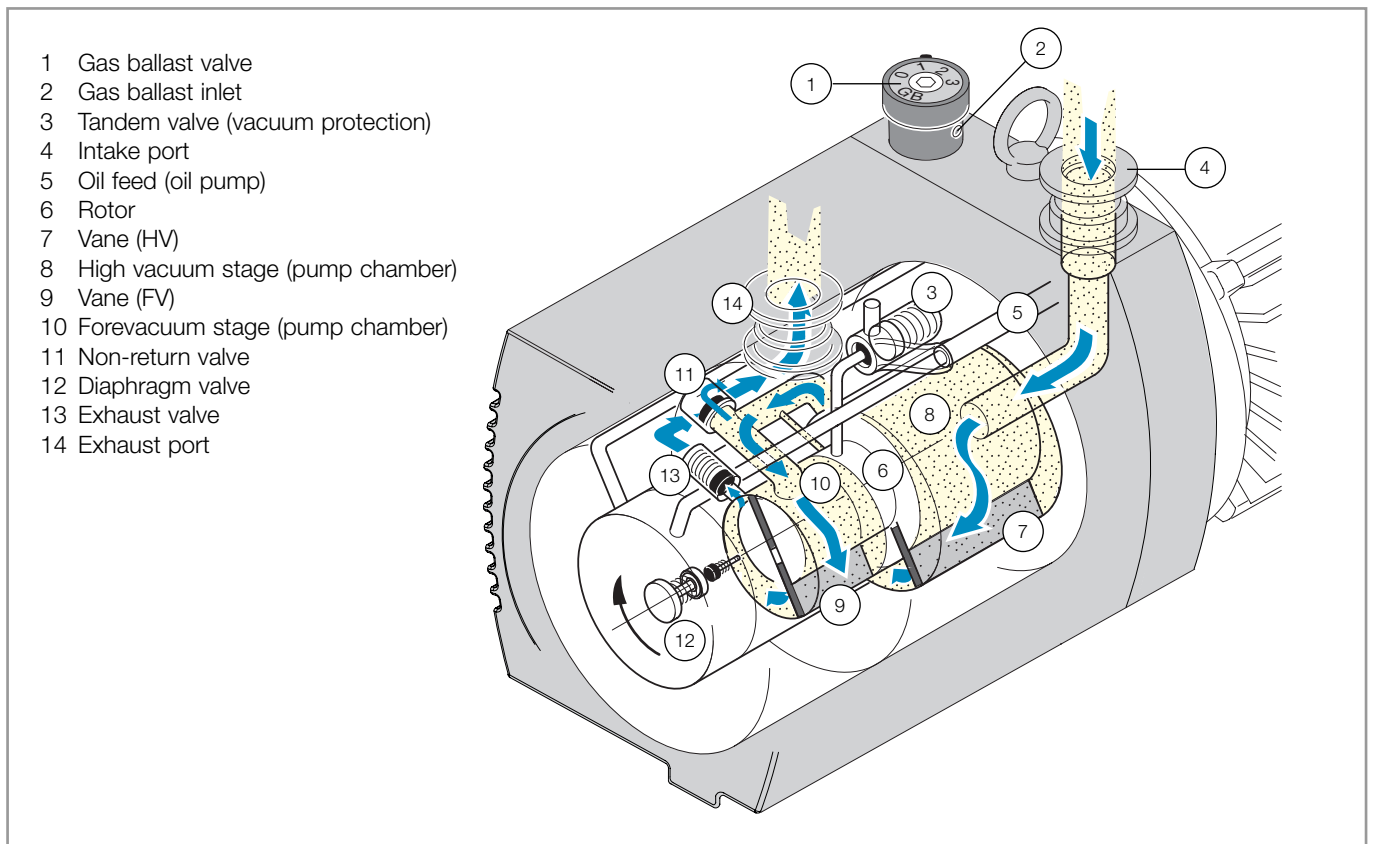

Fig. 2 Operating principle of a TRIVAC NT 5 (other TRIVAC NT types operate in a similar way)

1.1 Principle of Operation

The rotor (2/6) which is eccentrically arranged in the pump housing (pump chamber) has two radially sliding vanes (2/7 and 2/9) which divide the pump chamber of the pump into several chambers.

The volume of each chamber changes periodically with each turn of the rotor so that the gas at the intake port (2/4) is sucked in. The gas enters the pump chamber, and after the admission aperture has been sealed off by the vane, the gas is compressed and moved on.

The compressed gas is ejected from the pump chamber through the exhaust valve. Oil which is entrained in the gas is roughly separated by an internal demister and at the same time any mechanical contaminations are also removed from the oil. The gas exits the pump through the exhaust port.

Oil injected into the pump chamber serves the purpose of sealing and lubrication. The knocking noise (oil slap) which normally occurs when the pump approaches its ultimate pressure is avoided by injecting a small amount of air into the oil so that a silencing effect is attained.

Description

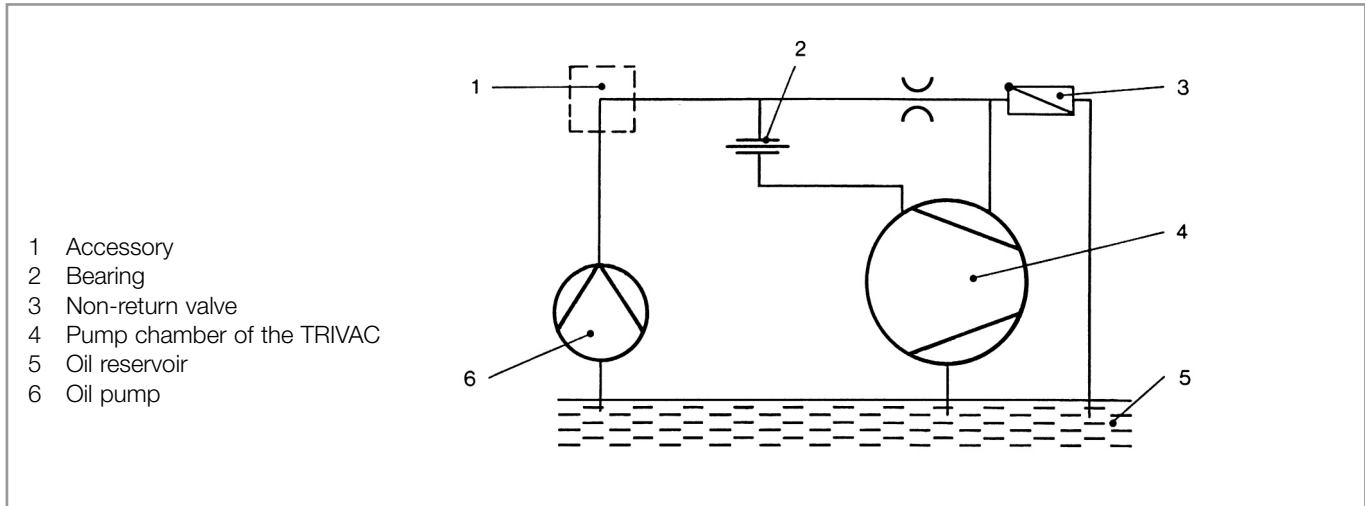

Fig. 3 Diagram for the lubrication system

By opening the gas ballast valve (2/1) it is possible to admit a controlled quantity of air (gas ballast) into the pump chamber while the compression process is in progress. The gas ballast will prevent the condensation of vapours within the pump up to the extent of the vapour tolerance levels as stated in the specifications for the pump (these data refer to water vapour).

A special lubrication system with forced lubrication of the sliding bearings has been developed to enable operation of the pump at intake pressures up to 1000 mbar.

An oil pump supplies the oil from the oil reservoir into a high pressure oil system which in turn supplies all bearings. From here the oil enters the pump chamber of the vacuum pump.

The oil pump is located in bearing piece of the high vacuum stage. Separation of oil and gas in the pump involves two stages. First an internal demister which is arranged ahead of the exhaust valve ensures the creation of larger droplets.

Next these are returned back to the oil reservoir via a separation panel. This ensures a minimal loss of oil.

This and the combination with the large usable oil reservoir, results in long intervals between the oil exchanges, even at high intake pressures.

The gas ballast valve (GB) is opened or closed by turning it (positions 0, 1, 2, 3).

| GB position | Explanation |
|-------------|---|
| 0 | No gas ballast, maximum ultimate pressure |
| 1 | For cleaning the pump's oil at a good ultimate pressure and low oil consumption |
| 2 | Good water vapour tolerance without producing excessive noise |
| 3 | Maximum water vapour tolerance in accordance with the technical data (Chapter. 1.3) |

Settings at the gas ballast valve

When the pump is at standstill (mains power failure, or when the pump is shut down) the pump chamber is hermetically sealed off by two safety valves (tandem valve and gas ballast diaphragm valve) which are controlled through the oil pressure.

This reliably avoids any inadvertent venting of the vacuum chamber and the backstreaming of oil.

1.2 Supplied Equipment

The TRIVAC NT is supplied with the following basic equipment:

- Pump with motor
- Separately included oil filling (see Chapter 1.2.1)
- Separately included inlet screen with O-ring
- Operating Instructions

The connection ports are provided with foil protectors for protection during shipping.

The TRIVAC NT pumps having an AC motor are supplied ready for operation, complete with switch, built-in thermal motor overload protection, mains cord (1.8 m long) and a mains plug which depends on the country of use.

Exempt from this is the dual voltage motor for 110 V-120 V; 208 V-240 V. The mains cord for this voltage range must be ordered separately, see Accessories, Chapter 1.5.

The three-phase models do not come with the accessories needed for the electrical connection. However, these accessories are available upon request.

1.2.1 Notes on the Oil and How to Order

Mineral oil is used as standard. If any other kind of special oil is being used, this fact will be indicated by a sticker on the oil box stating the type of special oil used.

Not all types of oil have been released for all pumps. You must only use the kind of oil which has been specified for the particular pump.

Note

Caution

Description

1.3 Technical Data

| | | TRIVAC NT 5 | TRIVAC NT 10 |
|--|----------------------------------|--|------------------------|
| Nominal pumping speed* 50/60 Hz | $\text{m}^3 \cdot \text{h}^{-1}$ | 6/7.3 | 12/14.6 |
| Pumping speed 50/60 Hz | $\text{m}^3 \cdot \text{h}^{-1}$ | 5.2/6 | 9.9/11,3 |
| Ult. partial pressure without gas ballast | mbar | $\leq 5 \cdot 10^{-4}$ | $\leq 5 \cdot 10^{-4}$ |
| Ult. total pressure without gas ballast** | mbar | $\leq 2 \cdot 10^{-3}$ | $\leq 2 \cdot 10^{-3}$ |
| Ult. total pressure w. gas ballast (stage 2)** | mbar | $\leq 3 \cdot 10^{-2}$ | $\leq 3 \cdot 10^{-2}$ |
| Water vapour tolerance | | | |
| Stage 1 | mbar | 10 | 10 |
| Stage 2 | mbar | 30 | 20 |
| Stage 3 | mbar | 40 | 30 |
| Water vapour capacity (max. at stage 3) | $\text{g} \cdot \text{h}^{-1}$ | 150 | 210 |
| Oil filling, min./max. | l | 0.75 / 1.25 | 0.75 / 1.25 |
| Noise level * acc. to DIN 45 635, (without gas ballast) | dB (A) | ≤ 49 | ≤ 49 |
| Permissible ambient temperature | °C | 12 - 50 (EURO motor) / 12 - 40 (USA/Japan motor) | |
| Motor power 50/60 Hz | W | 450/550 | 450/550 |
| Speed 50/60 Hz | min^{-1} | 1350/1650 | 1350/1650 |
| Motor protection | IP | 54 | 54 |
| Weight with operating agent ** | kg | 22.1 | 24.2 |
| Connections, intake and exhaust | DN | 25 KF | 25 KF |
| Dimensions | mm | see Figure 4 | see Figure 4 |

* acc. to DIN 28 426 T1, ** acc. to DIN 28 400 ff, with 3-ph. motor

Caution

Only provided the lubricants recommended by us will we guarantee that the pump will attain its specified technical data.

1.3.1 Motor Dependent Data

| Motors for TRIVAC NT 5 | Voltage [V] | Frequency [Hz] | Voltage tolerance | Power consumption [W] | Nominal current [A] | Fuse* [A] | Protection IP | Nom. speed [min ⁻¹] |
|-------------------------------|-------------------------|----------------|-------------------|-----------------------|---------------------|-----------|---------------|---------------------------------|
| EURO motor | 220-240/230 | 50/60 | ± 5 % | 450/540 | 2.5/2.4 | 10 | 54 | 1350/1650 |
| World motor | Δ 200-240/ Y 346/415 | 50 | ± 5 % | 550 | 2.8 1.6 | 6 | 54 | 1500 |
| World motor | Δ 200-266/ Y 346-460 | 60 | ± 5 % | 650 | 2.8 1.6 | 6 | 54 | 1800 |
| Dual voltage motor (DV motor) | 110-120/ 208-240 | 50/60 | ± 5 % | 490/550 | 6.8/5.6 3.4/2.8 | 10 | 54 | 1350/1650 |
| Japan motor | 100 | 50/60 | ± 5 % | 540/630 | 8.4/7.2 | 10 | 54 | 1350/1650 |

| Motors for TRIVAC NT 10 | Voltage [V] | Frequency [Hz] | Voltage tolerance | Power consumption [W] | Nominal current [A] | Fuse* [A] | Protection IP | Nom. speed [min ⁻¹] |
|-------------------------------|-------------------------|----------------|-------------------|-----------------------|---------------------|-----------|---------------|---------------------------------|
| EURO motor | 220-240/230 | 50/60 | ± 5 % | 450/540 | 2.5/2.4 | 10 | 54 | 1350/1650 |
| World motor | Δ 200-240/ Y 346/415 | 50 | ± 5 % | 550 | 2.8 1.6 | 6 | 54 | 1500 |
| World motor | Δ 200-266/ Y 346-460 | 60 | ± 5 % | 650 | 2.8 1.6 | 6 | 54 | 1800 |
| Dual voltage motor (DV motor) | 110-120/ 208-240 | 50/60 | ± 5 % | 490/550 | 6.8/5.6 3.4/2.8 | 10 | 54 | 1350/1650 |
| Japan motor | 100 | 50/60 | ± 5 % | 540/630 | 8.4/7.2 | 10 | 54 | 1350/1650 |

*the values stated for the fuses are recommended values only!

Values for up-front fuses for short-circuit protection. Please take note of the information provided by the manufacturers of contactors and motor protection switches.

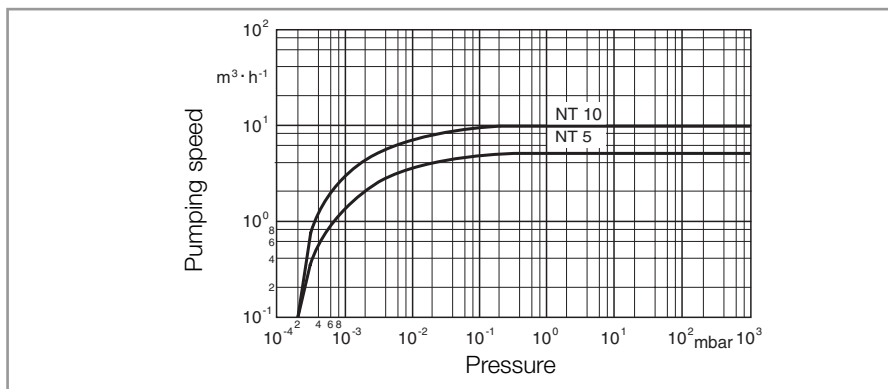
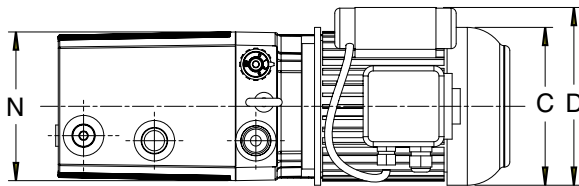
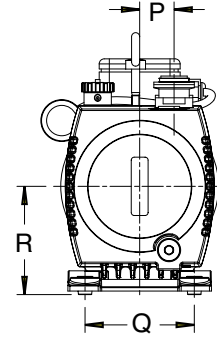
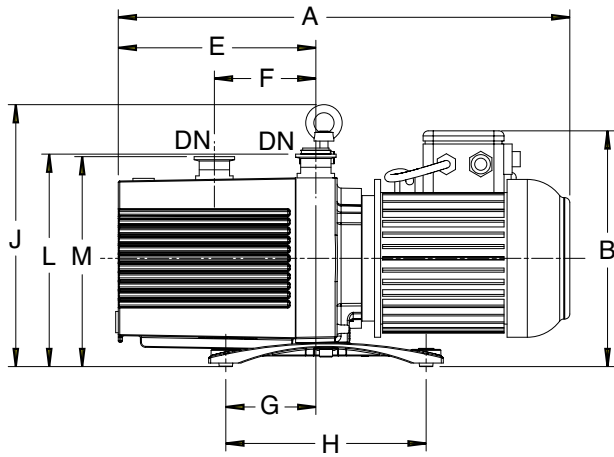

Fig. 4 Pumping speed curves of the TRIVAC NT 5 and NT 10

Description



| Dim. | Description | NT 5 | NT 10 |
|------|--------------|------|-------|
| A | 1~, EURO | 427 | 446 |
| | 1~, DV motor | 427 | 446 |
| | 3~, World | 427 | 446 |
| | 1~, Japan | 427 | 446 |
| B | 1~, EURO | 233 | 233 |
| | 1~, DV motor | 251 | 251 |
| | 3~, World | 214 | 214 |
| | 1~, Japan | 233 | 233 |
| C | 1~, EURO | 156 | 156 |
| | 1~, DV motor | 156 | 156 |
| | 3~, World | 156 | 156 |
| | 1~, Japan | 156 | 156 |
| D | 1~, EURO | 174 | 174 |
| | 1~, DV motor | 156* | 156* |
| | 3~, World | 156 | 156 |
| | 1~, Japan | 178 | 176 |
| E | | 195 | 195 |
| F | | 100 | 100 |
| G | | 95 | 89 |
| H | | 198 | 198 |
| J | | 259 | 259 |
| L | | 210 | 210 |
| M | | 208 | 208 |
| N | | 147 | 147 |
| P | | 34 | 34 |
| Q | | 108 | 108 |
| R | | 107 | 107 |
| DN | | 25 | 25 |

* Capacitors in the junction box
 DV = Dual voltage motor

(all dimensions are in mm)

Fig. 5 Dimensional drawing

1.4 Ordering Information

| | P/N |
|---|---------|
| TRIVAC NT 5 with 1- Dual voltage-Motor | 140 212 |
| TRIVAC NT 5 with 3- World motor | 140 213 |
| TRIVAC NT 5 with 1- Euro-Motor | 140 214 |
| TRIVAC NT 5 with 1- Japan motor | 140 216 |
| TRIVAC NT 10 with 1- Dual voltage motor | 140 312 |
| TRIVAC NT 10 with 3- World motor | 140 313 |
| TRIVAC NT 10 with 1- Euro motor | 140 314 |
| TRIVAC NT 10 with 1- Japan motor | 140 316 |

1.5 Accessories

| | P/N |
|--|----------|
| Horizontal inlet | 140 102 |
| Horizontal exhaust | 140 103 |
| Exhaust filter AF 8, DN 16 KF | 190 50 |
| Exhaust filter AF 10, DN 25 KF | 190 51 |
| Replacement filter elements FE 8 (pack of five) | 190 80 |
| Replacement filter elements FE 10 (pack of five) | 190 81 |
| Drain cock for exhaust filter AF 8/10 | 190 95 |
| Condensate separator AK 8, DN 16 KF | 190 60 |
| Condensate separator AK 10, DN 25 KF | 190 61 |
| Oil drain cocks (for NT 5 / NT 10) | 190 90 |
| Manual oil return through GB inlet (kit for AF 8-16) ARM | 190 93 |
| Mains cord NEMA 100 V - 120 V 50/60 Hz | 20081090 |
| EUROSCHUKO 200 V - 240 V 50/60 Hz | 20081091 |
| NEMA 200 V - 240 V 50/60 Hz | 20081141 |

The permissible motor voltage may deviate from the cable designation.
The motor voltage released and stated on the nameplate of the motor applies!

| | | |
|-------------|------|--------|
| Mineral oil | 1 l | 177 01 |
| | 5 l | 177 02 |
| | 20 l | 177 03 |

Use only types of oil specified by Oerlikon Leybold Vacuum.
Alternative oils are stated upon request.

The necessary connection components for connecting the exhaust filter and the condensate separator in each case are stated in the following:

| | |
|--|--------|
| 1 Elbow DN 25 KF | 184 37 |
| 2 Centering rings with O-ring DN 25 KF | 183 27 |
| 2 Clamping rings DN 25 KF | 183 42 |

Caution

Note

Transporting and Storing

2 Transporting and Storing

Caution

Pumps which are filled with operating agents must be only transported standing upright. Otherwise oil may escape. Avoid any other orientations during transportation.

Warning



Check the pump for oil leaks, there exists the risk of falling on oil spills.

To lift the pumps use only the lifting eye provided and the specified lifting facilities.

Store the pump before using it again preferably at room temperatures (20 °C). Before storing the pump, properly separate the pump from the vacuum system, purge it with dry nitrogen and change the oil.

Seal off the inlet and discharge openings of the pump with the transport seals provided upon delivery of the pump.

Set the gas ballast switch to the position "0".

When intending to store the pump for a longer period of time, place it in PE bag. Add some desiccant (silica gel) into the bag and seal off the bag.

When having shelved the pump for more than one year, perform maintenance on the pump and an oil exchange before recommissioning the pump. We recommend to contact our service.

3 Installation

3.1 Placement

The standard pump is not suited for placement in areas with explosive atmospheres. Please contact us first when planning such an application.

The TRIVAC NT can be placed freely on a flat and horizontal surface.

The rubber elements under the pump's base prevent the pump from slipping. If the pump is to be permanently attached, this may be done by making use of the holes in the rubber elements and a threaded bolt or similar.

The inclination of the pump (without additional fixing means) and with possibly attached standard accessories must not exceed an angle of 10° from the vertical axis.

The rubber elements act as vibration absorbers. For this reason they must not be compressed by the screws.

When installing the pump you must ensure accessibility of all connections and controls.

Select a place for the pump which ensures a sufficient air circulation for cooling the pump (keep front and rear sides unobstructed).

The ambient temperature around the pump should not exceed 50 °C (in the case of USA and Japan motors 40 °C) and not drop below 12 °C (see Chapter 4.3.3).

If required, the crane eye may be removed.

Before operating the pump, please check the oil level first.

3.2 Conforming Utilisation

The TRIVAC NT pumps are suited of pumping gases and vapours out of vessels and vacuum systems down into the medium vacuum pressure range. The standard pumps are not designed to handle oxygen at concentrations exceeding the concentration of oxygen in the atmosphere. Moreover, these pumps are not suited for pumping of hazardous gases or extremely aggressive or corrosive media.

3.3 Connection to the System

Before connecting the pump, the shipping seals on the connection flanges (6/1 and 6/2) must be removed. If residues of adhesives are present on the connecting flanges you must remove these using a suitable solvent like alcohol, for example.

Warning



Caution

Caution

Retain the transport seals

Installation

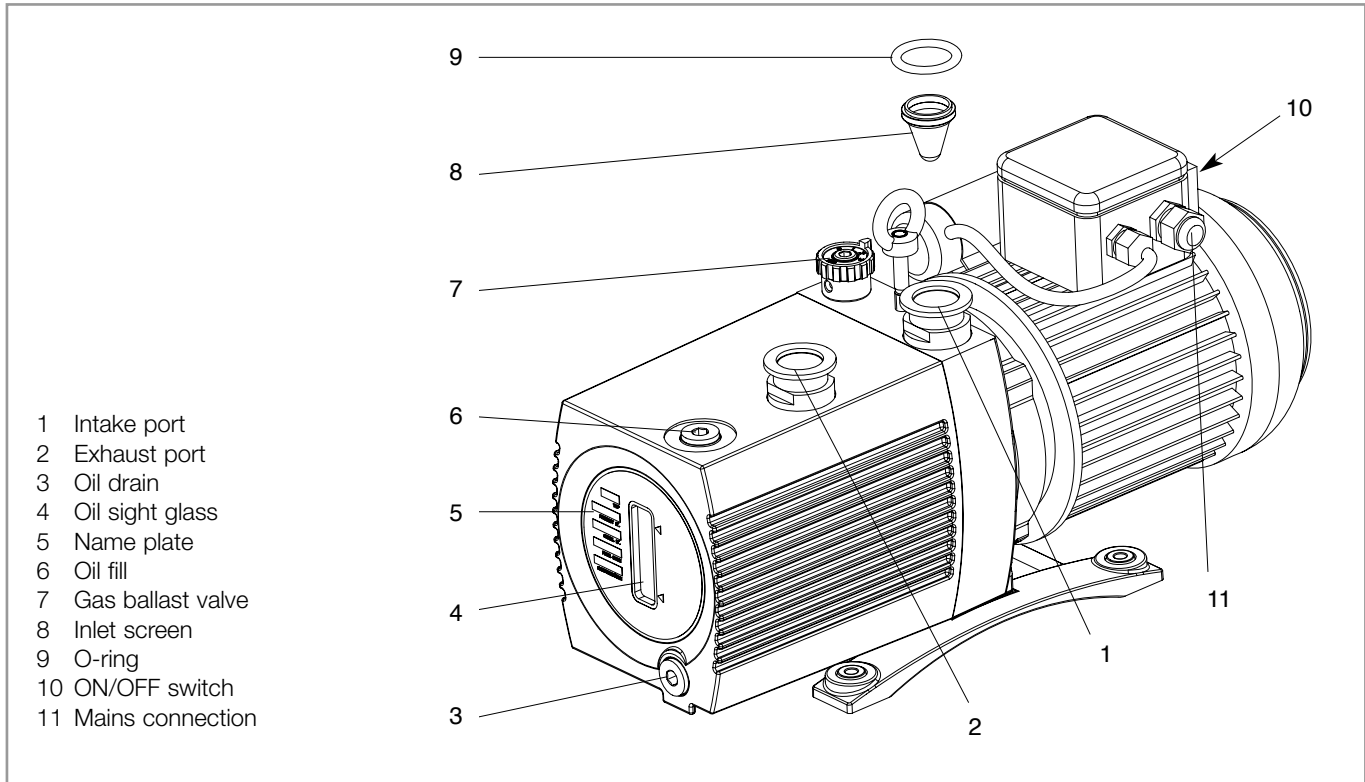

Fig. 6 Connections and controls

Caution

Insert the inlet screen (6/8) with the O-ring (6/9).

The intake and exhaust lines are fitted with standard small flanges. The connection flanges must be clean and undamaged.

The intake line and the exhaust line must be connected using corrugated pipes or vacuum hoses so that no mechanical forces can be transferred to the pump.

The intake line must be clean. Any deposits in the intake line will tend to degas and impair the attainable vacuum pressures.

The cross section of the intake and exhaust line must at least be of the same diameter as that of the pump connections.

An intake line which is too small in diameter will throttle the pumping speed.

Warning



The pressure in the oil box must not exceed 1.5 bar (absolute).

An exhaust line which is too small in diameter or which is blocked can result in the formation of overpressures within the pump. Possible consequences can be a damaged or even burst open pump. For this reason the exhaust line must be checked from time to time to ensure that there are no obstructions.

When pumping vapours we strongly recommend the installation of a condensate separator on the suction side and also on the exhaust side.

The exhaust line must be laid so that it slopes down and away from pump (lower than the pump) to prevent any condensate from flowing back into the pump. If a sloping line can not be installed, a separator must be fitted.

When the oil mist is to be removed from the exhaust gas flow we recommend the installation of an exhaust filter.

When pumping inert gases the pump's gas ballast inlet can directly be connected to the system by an adaptor (for this the gas ballast knob must be removed).

3.4 Electrical Connection

Risk of suffering injury!

During all electrical work ensure that the power supply lines have reliably been switched off and protected against being switched on inadvertently (tagout/lockout). The electrical connections may only be provided by a trained electrician in accordance with EN 50110-1, for example.

In order to prevent the pump from running up unexpectedly after a power failure, the pump must be connected to the system controller in such a way that the pump may only be re-started manually. This applies equally after the pump has been switched off through an emergency switch.

The pumps are supplied with either an AC motor or a three-phase motor.

3.4.1 Pumps with AC Motor

The pump may be directly connected via its mains cable and its plug to the mains.

In the case of 230 V mains, 6 A slow blow or 10 A fast blow fusing is required as a minimum.

A check on the direction of rotation is not required since this is fixed.

The thermal motor overload protector protects the motor in case it is overloaded.

The mains voltage must comply with the voltage stated on the name plate.

When the thermal motor overload protection system has switched the motor off, the motor will automatically cut in again when the temperature has dropped below the maximum permissible operating temperature.

Caution

Warning



Warning



Installation

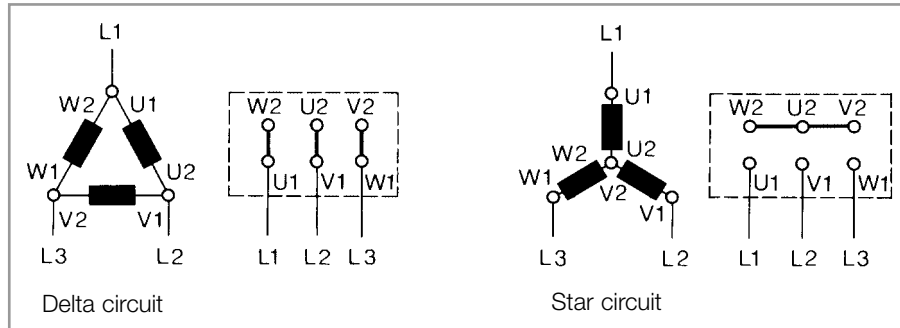

Fig. 7 Wiring diagram for the TRIVAC NT with 50 Hz three-phase motor

3.4.2 Pumps with Three-Phase Motor

The TRIVAC NT pumps equipped with a three-phase motor are delivered without the components required for their electrical connection.

You must connect the pump using an appropriately rated cable (we recommend: AWG 18 for the NT5 and NT10) and a suitably rated motor protection switch. The value set on the motor protection switch must correspond to the current rating stated on the name plate of the motor.

Shown in Fig. 7 is the way in which the pump having a three-phase motor (50/60 Hz) may be connected in Star or Delta fashion. Please also take note of the information given in the junction box or on the name plate of the motor.

Caution

After having connected the motor and each time after having made a change to the wiring you must check the direction of rotation.

For this switch the motor on briefly and determine whether or not a suitable plate (a blank flange, for example) held in front of the intake is sucked towards the pump's body. If this is not the case you must interchange two of the mains phases.

Note the direction indicating arrow on the fan cowl.

3.4.2.1 Current Drawn by the Three-Phase Motors of the TRIVAC NT 5 and NT 10

| | Voltage ranges for the three-phase motors | Max. current consumption at an intake pressure of about 300 mbar | Min. current consumption at ultimate pressure | Setting for the motor protection switch (motor data) |
|---------|---|--|---|--|
| Δ 50 Hz | 200 V - 240 V | 2.2 A - 2.6 A | 1.6 A - 2.5 A | 2.8 A |
| 60 Hz | 200 V - 266 V | 2.5 A - 2.3 A | 1.4 A - 1.9 A | 2.8 A |
| Y 50 Hz | 346 V - 415 V | 1.2 A - 1.5 A | 0.9 A - 1.4 A | 1.6 A |
| 60 Hz | 346 V - 460 V | 1.4 A - 1.35 A | 0.8 A - 1.2 A | 1.6 A |

4 Operation

4.1 Media Compatibility

Before pumping oxygen (or other highly reactive gases) at concentrations exceeding that of the atmosphere (> 21 % for oxygen), it is necessary to use a special pump. This special pump must be modified and degreased and a special lubricant (like PFPE) must be used.

When pumping toxic, chemical, radioactive and corrosive gases as well as pyrophorous substances, the operating company is under the obligation to comply with the national and international safety regulations and guidelines. Regarding the suitability of the TRIVAC NT pumps for special applications in which such gases, respectively substances shall be pumped, Oerlikon Leybold Vacuum should be consulted first.

The pumps are not suited for pumping liquids or very dusty media.

Corresponding protection facilities need to be provided.

The pump is as standard not suited for pumping hazardous gases or vapours.

For inquiries, call our technical sales department.

4.2 Start Up

Check the oil level each time before switching on the pump.

When starting the pump up for the first time and each time changes are made to the electrical power supply connection, check the direction of rotation in the case of those pumps which are equipped with a three-phase motor (in accordance with Chapter 3.4).

The pump is started up by operating the ON/OFF switch (6/10 - does not apply in the case of pumps with a three-phase motor). The ON/OFF switch may be operated at all pressures.

During initial start up and after a longer period during which the pump has not been used, the pump may not immediately attain the specified ultimate pressure because the oil has to be degassed first.

For this you should let the pump run for about 30 minutes with the intake line closed and the gas ballast valve (6/7) open (position 2 of the gas ballast valve).

Avoid exposing any part of the human body to the vacuum. There is the risk of suffering injury. Never operate the pump with an open intake port. Vacuum connections as well as oil feed and discharge openings must not be opened while the pump is operating.

The pressure in the oil box must not exceed 1.5 bar (absolute).

An exhaust line which is too small in diameter or which is blocked can result in the formation of overpressures within the pump. Possible consequences can be a damaged or even burst open pump. Thus the exhaust line must be checked from time to time to ensure that there are no obstructions.

Warning



Caution

Warning



4.3 Operation

These pumps are capable of pumping gases and vapours. Vapours can only be pumped provided the gas ballast valve is open and provided the pump has attained its operating temperature.

The maximum vapour tolerance is attained when the gas ballast valve (6/7) is set to position 3.

4.3.1 Pumping of Non-Condensable Gases and Vapours

In the presence of excess quantities of permanent gases the TRIVAC NT may be operated without gas ballast (position 0), provided the saturation vapour pressure at the operating temperature is not exceeded during compression.

If the composition of the gases which are to be pumped is not known and if the possibility of condensation within the pump can not be excluded, we recommend operation of the pump with the gas ballast valve open (in accordance with Chapter 4.3.2).

4.3.2 Pumping of Condensable Gases and Vapours

With the gas ballast valve open and when the pump is running at its operating temperature, pure water vapour can be pumped up to the extent stated in the technical data for the pump (position 3 of the gas ballast valve). When the vapour pressure increases above the permissible level, the vapour will condense in the oil of the pump. When pumping vapours make sure that the gas ballast valve is open and that the pump has been running for at least 30 minutes with the intake line closed and with gas ballast.

Caution

It will be possible to pump vapours up to the permissible limit only after the pump has reached its operating temperature.

During the pumping process vapours may dissolve in the oil of the pump. This impairs the properties of the oil and there is the risk of corrosion within the pump. For this reason the pump must not be switched off immediately after termination of the process. The pump must remain on with the gas ballast valve open and the intake line sealed until all vapours which were dissolved in the oil have been removed.

We strongly recommend that the TRIVAC NT pumps be left running for about 30 minutes after termination of the process.

In the case of cyclic or repetitive processes the TRIVAC NT should not be switched off during the breaks between the individual work phases (low energy requirement when running at ultimate pressure). The gas ballast valve should be opened and the intake line should be sealed (through a valve, if possible).

When all vapours have been pumped from a process (drying, for example) the gas ballast valve can be closed to improve the attainable ultimate pressure.

4.3.3 Operating Temperature

Proper operation of the TRIVAC NT is ensured at ambient temperatures between 12 °C and 50 °C, with the exception of the pump models for the USA and Japan where a range of 12 °C to 40 °C applies.

For certain motors and for certain lubricants, operating the pump also at lower temperatures is possible. Call our technical sales office for more information.

When using SHC 224 Arctic oil, the pump will reliably run up even at a temperature of 5 °C.

When the pump is warm, the temperature at the surface of the oil box may rise to between 40 °C and 80 °C, depending on the load on the pump.

TRIVAC NT pumps may attain surface temperatures of over 80 °C. There is the danger of receiving burns.

4.4 Shutting Down/Shelving

During normal use of the TRIVAC NT it will be sufficient to electrically switch off the pump. Further measures are not required.

After having pumped condensable media, let the pump run for some time with the gas ballast valve open and the intake line blocked (see Chapter 4.3.2).

When pumping aggressive or corrosive media and also in the case of long process interruptions (overnight, for example) we recommend that you let the pump run with the intake line sealed and with the gas ballast switched on.

This helps to prevent the occurrence of standstill corrosion.

If the pump is to be switched off for a longer period of time after it has been pumping aggressive or corrosive media or if the pump is to be shelved, proceed as follows:

When hazardous substances have been pumped ensure that the appropriate safety precautions are observed.

For more information please contact our technical sales department.

Seal off the intake port. The use of special conservation or anti-corrosion oils is not required.

Shut Down through Monitoring Components

When the pump has been switched off due to overheating sensed by the motor coil protector (single phase motors only), the pump must only be started manually after the pump has cooled down to the ambient temperature and after having removed the cause first.

Failure of the Control System or the Mains Power

In order to prevent the pump from running up unexpectedly after a mains power failure, the pump must be integrated in the control system in such a way that the pump can only be switched on again manually. This applies equally to emergency cut-out arrangements.

Note

Warning



Warning



Warning



Warning



Maintenance

Warning



5 Maintenance

Before starting any disassembly work, disconnect all electrical connections to the pump. Reliably prevent the pump from running up (lockout/tagout).

When the pump has been pumping hazardous substances contrary to the information provided in Chapter 4.1, determine the nature of the hazard and make sure that the appropriate safety measures are observed.

Observe all safety regulations.

Due to the concept of the TRIVAC NT these pumps will hardly require any maintenance under normal operating conditions. The necessary maintenance work is described in the following chapters. In addition a maintenance schedule is provided in Chapter 5.2.

All work should be left to trained personnel. Improperly performed maintenance or repair work endangers the durability and operational readiness and will lead to difficulties when wanting to file any warranty claims.

Also available from Oerlikon Leybold Vacuum are seminars covering practical aspects like maintenance, repair and checking of the TRIVAC NT which are run under the supervision of our experts. For more information on these seminars please contact us at Oerlikon Leybold Vacuum.

If the TRIVAC NT is used in much contaminated ambient air you must ensure that operation of the gas ballast system and the air cooling is not impaired.

Spare parts are contained in the Repair Sets and in the Maintenance Kits. If required, ask us for a quotation on spare parts.

In the case of custom models and variants please always state the custom, variant and serial number.

5.1 Service at Oerlikon Leybold Vacuum

Contamination

If you send equipment to Oerlikon Leybold Vacuum indicate whether the pump is free of substances damaging to health or whether it is contaminated. If it is contaminated also indicate the nature of hazard. To do so, you must use a preprinted form which we shall send to you upon request.

Form

A copy of this form is reproduced at the end of these Operating Instructions: "Declaration of Contamination of Compressors, Vacuum Pumps and Components". Moreover, you may download a suitable form from the Internet: www.oerlikon.com → Oerlikon Leybold Vacuum → Documentation → Download Documents. Please attach this form to the pump or enclose it with the pump.

This "Declaration of Contamination" is required to meet the requirements of German Law and to protect our personnel. Oerlikon Leybold Vacuum must return any pumps without a "Declaration of Contamination" to the sender's address.

5.2 Maintenance Schedule (recommendation)

| No. | Rotary vane pump TRIVAC NT | Measumem./test quantity operating/auxiliary agents | Interval | | | | | Remarks |
|-----|--|---|----------|---|----|---|-----|--|
| | | | VE | t | 6m | a | n-a | |
| 1 | Operate the pump with gas ballast for at least 45 minutes. | | | x | | | | Condensed water is thereby removed from the oil. |
| 2 | Check the oil level and change the oil as required. | Oil: N 62 or special and alternative types of oil | x | x | | | | Topping up: only after the pump has been switched off. |
| 3 | Check the quality of the oil and change the oil as required. | Visually Chemically Mechanically | x | x | | | | Visually: Normal condition light and transparent, oil change is required at increasing discoloration. Chemically: to DIN 51558, when the neutralisation value exceeds > 2, then an oil change is required. Mechanically: when the dynamic viscosity at 25 °C > 240 mPas, then an oil change is required. |
| 4 | Clean inlet screen in the intake and exchange it as required. | Suitable cleaning agent and compressed air. | | | x | | | <ul style="list-style-type: none"> ■ Clean the inlet screen with a cleaning agent and blow it clean with compressed air under a suction hood. ■ Replace defective inlet screen. Use a cleaning agent which complies with the national/international specifications. Observe the safety regulations which apply to the cleaning agent used. |
| 5 | Clean the internal demister and change it as required. | Suitable cleaning agent. | | | | | x | Perform cleaning also in advance of the scheduled maintenance interval when the noise increases more and more. <ul style="list-style-type: none"> ■ Clean the internal demister with cleaning agent. ■ Replace a defective internal demister. ■ Dispose the used internal demister as special waste. Use a cleaning agent which complies with the national/international specifications. Observe the safety regulations which apply to the cleaning agent used. |
| 6 | Check the coupling bushings for damage and wear. | | | | | | 3 | Check also in advance of the scheduled maintenance interval in case of extreme noise.* |
| 7 | Change the oil. Clean the oil sight glass. | Oil: N 62 or special and alternative types of oil. Suitable cleaning agent and compressed air. | | | | | x | Oil change: <ul style="list-style-type: none"> ■ First oil change after 100 operating hours. ■ Pump switched off and cold. Change the oil while the pump is cold so as not to release absorbed gases. Clean oil sight glass with a cleaning agent and blow it clean with compressed air under a suction hood. Use a cleaning agent which complies with the national/international specifications. Observe the safety regulations which apply to the cleaning agent used. |
| 8 | Check the pump's fan, the motor fan and the cooling fins of the motor for dirt, and clean as required. | Brush and industrial vacuum cleaner. | | | | | 3 | Perform cleaning also in advance of the scheduled maintenance interval when the pump or the motor get too warm. Warning: switch the pump off and prevent it from |

Key to the maintenance schedule

VE = Perform maintenance before switching the system on

t = Daily maintenance

6m = Maintenance every six months

a = Annual maintenance

n-a = Maintenance every n years

* At high gas throughputs and higher temperatures within a pressure range >100 mbar shorter maintenance intervals apply.

Every 3 years we recommend servicing of the pump involving the following steps:

- Cleaning
- Checking of individual components
- Replacement of all gaskets
- Functional check.

This check should be performed by the Oerlikon-Leybold-Vacuum-Service.

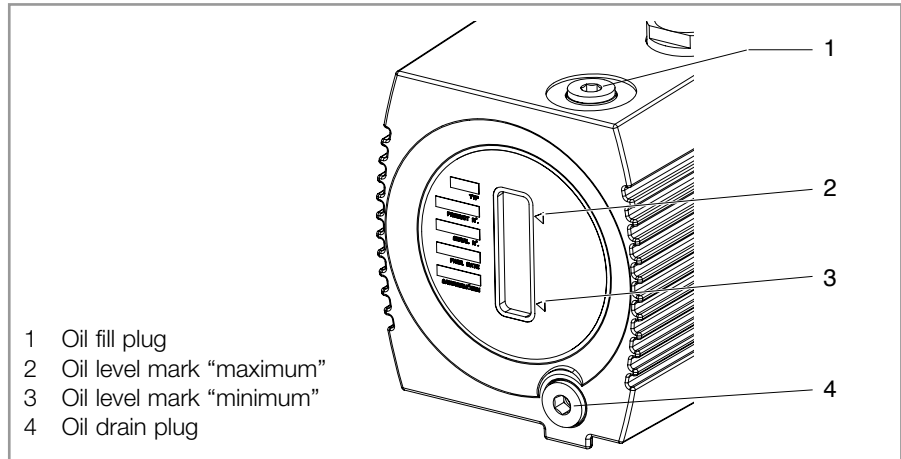

Fig. 8 Oil change

5.3 Checking the Oil Level

During operation the oil level of the TRIVAC NT must always be visible between the marks on oil sight glass (8/2 and 8/3). The quantity of oil must be checked and topped up as required.

Caution

Check and top up oil only with the pump switched off.

Oil check for N 62

The ageing process of the standard oil N 62 / HE 200 basically depends on the operating conditions of the pump.

You may check the condition of the oil as follows:

a) Visually

Normally the oil will be light and transparent. In the case of increasing discolouration of the oil (it becomes darker) we recommend that you exchange the oil.

b) Chemically

The neutralisation value for N 62 is determined in accordance with DIN 51558. When the neutralisation value exceeds the value of 2 you must change the oil.

c) Mechanically

When the viscosity of N 62 exceeds a value of 240 mPas at 25 °C (20 % over the viscosity of fresh oil) we recommend that you change the oil.

When gases or liquids are dissolved in the oil, the attainable ultimate pressure will be impaired. In such cases the oil may possibly be degassed by letting the pump run for about 30 minutes with the intake line closed and the gas ballast valve open.

Let the quantity of oil needed for testing flow from the oil drain opening (8/4) into a beaker with the pump switched off and while still warm from operation.

Warning



Note the safety information given in Chapter 5.

5.4 Oil Change

Before pumping oxygen (or other highly reactive gases) at concentrations exceeding the concentration in the atmosphere (> 21 % for oxygen) it will be necessary to use a special pump. Such a pump will have to be modified and de-greased, and an inert special lubricant (like PFPE) must be used.

Hazardous substances may escape from the pump and from the oil. Introduce suitable safety precautions; wear protective gloves, face protection or a breathing mask, for example.

Observe all safety regulations.

For proper operation of the pump, it is essential that the pump has an adequate supply of the correct and clean oil at all times.

The oil must be changed when it looks dirty or if it appears chemically or mechanically worn out (see Chapter 5.3).

The oil should be changed after the first 100 operating hours and then at least every 2,000 to 3,000 operating hours or after one year. At high intake pressures and intake temperatures and/or when pumping contaminated gases, the oil will have to be changed much more frequently.

Further oil changes should be made before and after long-term storage of the pump.

If the oil becomes contaminated too quickly, install a dust and/or oil filter (see Chapter 1.5). For this, ask us for a quotation.

Exchange the oil always ensuring that the pump has been shut down.

Required tools: Allen key, size 8.

Remove the oil drain plug (8/4) and let the used oil drain into a suitable container. When the flow of oil slows down, screw the oil drain plug back in, briefly switch on the pump (max. 10 s) and then switch it off again. Remove the oil drain plug once more and drain out the remaining oil.

Screw the oil drain plug back in (check the gasket and reinstall a new one if necessary).

Remove the oil fill plug (8/1) and fill in fresh oil.

Screw the oil fill plug (8/1) back in.

Torque level for the oil fill and oil drain plug: 10 Nm

Gasket: P/N: 239 55 165

If there is the danger that the operating agent may present a hazard in any way due to decomposition of the oil, or because of the media which have been pumped, you must determine the kind of hazard and ensure that all necessary safety precautions are taken.

Warning



Caution

Warning



Maintenance

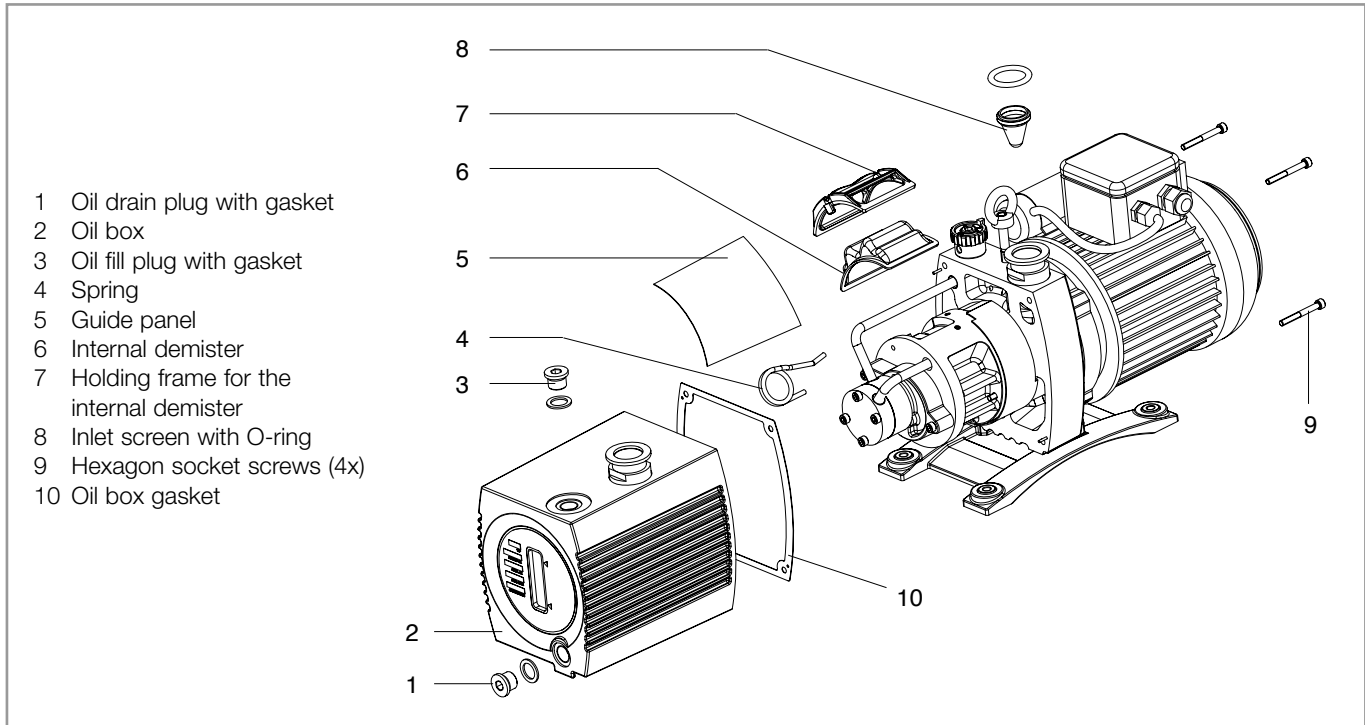

Fig. 9 Removing and installing the internal demister

Caution

We can only guarantee that the pump operates as specified by the technical data if the lubricants recommended by us are used.

5.5 Cleaning the Inlet Screen

Located in the intake port is a wire mesh sieve acting as a dirt trap for foreign objects. This sieve must be kept clean in order to avoid any throttling of the pump.

To clean the inlet screen (9/8) remove it from the intake and clean it in a vessel using a solvent. Then thoroughly dry it with compressed air. If the inlet screen is faulty you must replace it.

Note

Adapt the cleaning intervals according to the requirements. If large quantities of abrasive materials are involved you should install a dust filter in the intake line.

5.6 Removing and Inserting the Internal Demister

Required tools:

Allen keys 4 and 8 mm

The internal demister has been installed in a resilient frame. When it has clogged it will lift itself up periodically at high intake pressures in order to equalise the resulting pressure difference.

The increased noise level at high intake pressure is thus a sign for a clogged internal demister.

Depending on the operating conditions the internal demister will have to be cleaned regularly or it must be exchanged. Cleaning must be performed using a suitable solvent.

Switch the pump off and drain out the oil (in accordance with Chapter 5.4).

In order to collect the remaining oil in the oil box we recommend that you lift the pump up slightly at the side of the motor.

Unscrew the four hex. socket screws (9/9) of the oil box.

Pull the oil box (9/2) out to the front.

Remove the gasket (9/10) of the oil box.

Use a pair of pliers to pull the spring (9/4) out to the front.

Detach the holding frame (9/7) and the internal demister (9/6).

Clean all parts and check them for perfect condition and replace them as required. The oil box seal (9/10) must always be replaced.

Reassemble in the reverse order.

The torque level for the hexagon socket screws (9/9) amounts to 5.5 Nm.

Note

5.7 Disassembly and Assembly of the Electric Motor

Before starting with any work on the pump, always reliably disconnect the motor from its power supply. Remove the mains connection (three-phase motors only) or pull the mains plug (lockout/tagout).

Required tools:

Spanner size 8 and special tool for the tie rods.

We recommend that you remove the foot (10/8) of the pump.

Place the pump on the front side of the oil box (10/1). Remove the four hex. screws (10/2) from the fan cowl (10/3).

Detach the fan cowl.

Unscrew the four tie rods (10/4).

Maintenance

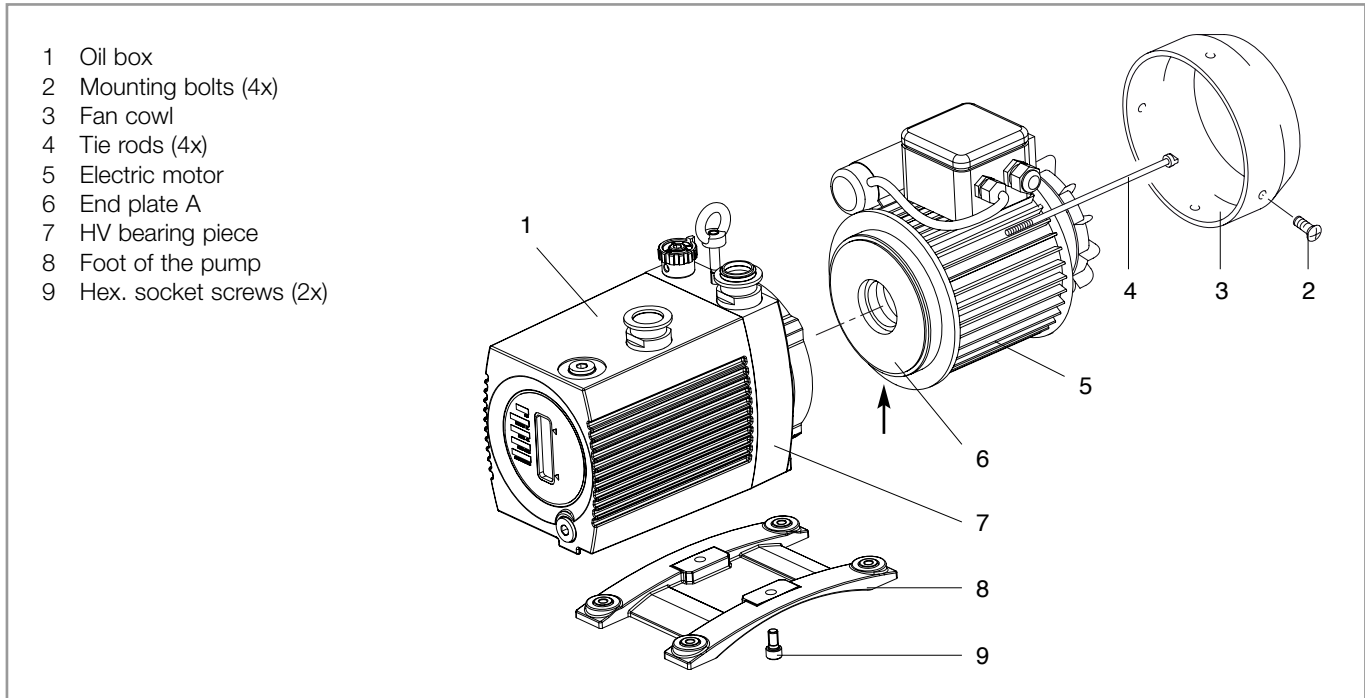

Fig. 10 Disassembly and assembly of the electric motor

Detach the motor (lever off using two screwdrivers inserted in parallel between the end plate A and the HV bearing piece) (10/6 and 10/7). Clean all parts and make sure that they are in perfect condition; replace any parts as required.

In case of wear exchange the coupling bushings; these are included in Repair Set 1.

Reassemble in the reverse order.

Tighten the tie rods crosswise to 4 Nm.

Tighten the bolts for the pump's base to 23 Nm.

Note

Especially note the position of the oil ejection hole (see arrow in Fig. 10) in the end plate A. The hole must always lead downward.

Troubleshooting

6 Troubleshooting

| Fault | Possible cause | Remedy | Repair note |
|---|--|--|-------------|
| Pump does not start up. | Faulty wiring. | Check the wiring and repair it. | - |
| | Motor protection switch not set correctly (three-phase motors only). | Properly set up motor protection switch. | 3.4 |
| | Power supply voltage does not match the rating of the motor. | Exchange the motor. | - |
| | Motor faulty. | Exchange the motor. | - |
| | Oil temperature less than 12 °C. | Warm up the pump and the oil of the pump or use a different oil. | 4.3.3/1.5 |
| | Oil is too thick. Exhaust filter or exhaust line is clogged. | Change the oil. Exchange the filter or clean the exhaust line. | 5.4 - |
| | Pump has seized (sign: blocked pump). | Repair the pump. | Service |
| Pump does not attain its ultimate pressure. | Unsuitable method of measurement or measuring equipment. | Use correct method of measurement and measuring equipment. Measure pressure directly at the intake port of the pump. | - |
| | External leak ¹⁾ . | Perform maintenance. | Service |
| | Dirty inlet valve. | Repair the valve. | Service |
| | Faulty exhaust valve. | Repair the valve. | Service |
| | Unsuitable oil. | Change the oil (possibly degas it). | 5.4 |
| | Intake line dirty. | Clean the intake line. | - |
| | Pump too small. | Check process data, possibly change the pump. | - |
| Pumping speed of the pump is too low. | Inlet screen in the intake line is clogged. | Clean the inlet screen. Preventive action: install a dust filter in the intake line. | 5.5 |
| | Clogged exhaust filter. | Exchange the filter element. | - |
| | Connection lines too narrow or too long. | Use sufficiently wide and short intake lines. | 3.3 |
| After switching the pump off the pressure in the system increases too fast. | System has a leak. | Check the system. | - |
| | Faulty intake valve. | Repair the valve. | Service |

* Repair information: see corresponding chapter of the Operating Instructions.

1) Bubble test: the warm pump with degassed oil is running without gas ballast with the intake blanked off. The exhaust line is lead into a vessel containing water. If an evenly spaced row of bubbles appears, then the pump has developed an external leak.

Troubleshooting

| Fault | Possible cause | Remedy | Repair note |
|---|--|--|-------------|
| Pump gets hotter than previously observed. | Supply of cooling air is obstructed. | Properly install the pump. | 3.1 |
| | Ambient temperature is too high. | Properly install the pump. | 3.1/4.3.3 |
| | Process gas is too hot. | Change the process. | - |
| | Not enough oil. | Fill in oil. | 5.3 |
| | Unsuitable oil. | Change the oil. | 5.4 |
| | Oil circulation is obstructed. | Clean or repair the oil channels. | Service |
| | Clogged exhaust filter or exhaust line. | Change the exhaust filter. Clean the exhaust line. | - |
| | Exhaust valve faulty. | Repair the valve. | Service |
| | Inner part worn out. | Replace the inner part. | Service |
| Deviating mains supply voltage. | Check power supply rating of the motor and the mains power supply. | | |
| Oil in the intake line or the vacuum chamber. | Oil coming from the system. | Check the system. | - |
| | Blocked intake valve. | Clean the valve. | Service |
| | Sealing surfaces of the intake valve damaged or dirty. | Clean or repair the intake port or the intake valve. | Service |
| | Oil level is too high. | Drain out excess oil. | 5.3 |
| Oil is turbid. | Condensation. | Degas the oil or change the oil and clean the pump. Preventive action: open the gas ballast valve or fit a separator. | 4.3.2/5.4 |
| The pump is extremely loud. | Oil level is much too low (oil is no longer visible). | Top up some oil. | 5.3/5.4 |
| | Silencing nozzle is clogged. | Clean or replace the silencing nozzle. | Service |
| | Intake pressure is too high. | Reduce the intake pressure. | - |
| | Clogged in internal demister. | Clean or replace the internal demister | Service |
| | Coupling bushings worn out. | Replace the coupling bushings. | - |
| | Damaged vanes or bearings. | Repair the pump. | Service |
| Pump shuts down after a few minutes. With a very high motor temperature or a very high current uptake (> 15 A). | Relay does not shut off the start-up capacitor. | Leave the motor to cool down (for at least 10 minutes). | - |
| | (Voltage too low). | Ensure that the supply voltage is correct (see motor nameplate). | - |

Wearing parts/waste disposal

7 Wearing and Original Parts

| | P/N. |
|--|-------------|
| Small maintenance kit NT 5/10 (without oil) | EK110002815 |
| Large maintenance kit NT 5 (without oil) | EK110002816 |
| Large maintenance kit NT 10 (without oil) | EK110002817 |
| Spare parts kit for shaft sealing ring replacement NT 5/10 (without oil) | EK110002814 |

8 Waste Disposal

The equipment may suffer contamination by the process or through environment influences. In such a case it must be professionally decontaminated. We offer such a service at fixed prices. Ask us for a quotation.

Damage to health and the environment

Contaminated components can cause damage to health and the environment. Before beginning work inform yourself as to the possible presence of any contamination. When handling contaminated components, observe the pertinent regulations and comply with the protection measures.

Disassemble clean equipment, separate and dispose of the materials according to their type.

When returning equipment back to us, please note the information provided in Chapter "5.1 Service at Oerlikon Leybold Vacuum".

Disposal of Waste Oil

Owners of waste oil are entirely self-responsible for proper disposal of this waste.

Waste oil from vacuum pumps must not be mixed with other substances or materials.

Waste oil from vacuum pumps (Leybold oils which are based on mineral oils) which are subject to normal wear and which are contaminated due to the influence of oxygen in the air, high temperatures or mechanical wear must be disposed of through the locally available waste oil disposal system.

Waste oil from vacuum pumps which is contaminated with other substances must be marked and stored in such a way that the type of contamination is apparent. This waste must be disposed of as special waste.

European, national and regional regulations concerning waste disposal need to be observed. Waste must only be transported and disposed of by an approved waste disposal vendor.

Contamination

Warning





EC Declaration of Conformity

We, Oerlikon Leybold Vacuum GmbH, hereby declare that the products specified and listed below which we have placed on the market, comply with the applicable EC Council Directives.

This declaration becomes invalid if modifications are made to the product without agreement of Oerlikon Leybold Vacuum GmbH.

Compliance with the EMC Directives requires that the components are installed within a system or machine in a manner adapted to EMC requirements.

Designation of the products: Rotary vane vacuum pump

Model: TRIVAC NT 5 / NT 10

Part-No.: 140212 to 140219 / 140312 to 140319

The product complies to the following European Council Directives:

- EC-Machinery Directive (98/37/EC)
- EC-Directive related to electrical equipment designed for use within certain voltage limits (2006/95/EC)
- EC-Directive relating to electromagnetic compatibility, (2004/108/EC)

Related, harmonized standards:

- EN 1012-2, 1996 Safety requirements for compressors and vacuum pumps – Part 2: Vacuum pumps
- EN 60034-1, 2004 Rotating electrical machines - Part 1: Rating and performance
- EN 60204-1, 2006 Safety of machinery - Electrical equipment of machines – Part 1: General requirements

Cologne

21.04.2008

Cologne

21.04.2008

Declaration of Contamination of Compressors, Vacuum Pumps and Components

The repair and / or servicing of compressors, vacuum pumps and components will be carried out only if a correctly completed declaration has been submitted. **Non-completion will result in delay.** The manufacturer can refuse to accept any equipment without a declaration.

A separate declaration has to be completed for each single component.

This declaration may be completed and signed only by authorised and qualified staff.

| | |
|--------------------------------|---|
| Customer/Dep./Institute: _____ | Reason for return <input checked="" type="checkbox"/> applicable please mark |
| _____ | <input type="checkbox"/> Repair <input type="checkbox"/> chargeable <input type="checkbox"/> warranty |
| Address _____ | <input type="checkbox"/> Exchange <input type="checkbox"/> chargeable <input type="checkbox"/> warranty |
| _____ | <input type="checkbox"/> exchange already arranged / received |
| Person to contact: _____ | Return only: <input type="checkbox"/> rent <input type="checkbox"/> loan <input type="checkbox"/> for credit |
| Phone: _____ Fax: _____ | Calibration: <input type="checkbox"/> DKD <input type="checkbox"/> Factory calibration |
| End user: _____ | <input type="checkbox"/> Quality test certificate DIN 55350-18-4.2.1 |

| | |
|--|----------------------------|
| A. Description of the Leybold product | Failure description: _____ |
| Material description: _____ | _____ |
| Catalog number: _____ | Additional parts: _____ |
| Serial number: _____ | Application Tool: _____ |
| Type of oil (Forevacuum pumps): _____ | Application Process: _____ |

| | | | | | | |
|--|--------------------------|--------------------------|-------------------------------------|-------------------------------|--------------------------|--------------------------|
| B. Condition of the equipment | | | | | | |
| | No ¹⁾ | Yes | No | Contamination: | No ¹⁾ | Yes |
| 1. Has the equipment been used ¹⁾ | <input type="checkbox"/> | <input type="checkbox"/> | <input checked="" type="checkbox"/> | toxic | <input type="checkbox"/> | <input type="checkbox"/> |
| 2. Drained (Product/service fluid) | <input type="checkbox"/> | <input type="checkbox"/> | <input type="checkbox"/> | corrosive | <input type="checkbox"/> | <input type="checkbox"/> |
| 3. All openings sealed airtight | <input type="checkbox"/> | <input type="checkbox"/> | <input type="checkbox"/> | flammable | <input type="checkbox"/> | <input type="checkbox"/> |
| 4. Purged | <input type="checkbox"/> | <input type="checkbox"/> | <input type="checkbox"/> | explosive ²⁾ | <input type="checkbox"/> | <input type="checkbox"/> |
| If yes which cleaning agent: _____ | | | | radioactive ²⁾ | <input type="checkbox"/> | <input type="checkbox"/> |
| and which method of cleaning: _____ | | | | microbiological ²⁾ | <input type="checkbox"/> | <input type="checkbox"/> |
| ¹⁾ if answered with "No" go to D. ← | | | | other harmful substances | <input type="checkbox"/> | <input type="checkbox"/> |

| | |
|---|---|
| C. Description of processed substances (Please fill in absolutely) | |
| 1. What substances have come into contact with the equipment: Trade name and / or chemical term of service fluids and substances processed, properties of the substances; According to safety data sheet (e.g. toxic, inflammable, corrosive, radioactive) | |
| Tradenname: _____ | Chemical name: _____ |
| a) _____ | |
| b) _____ | |
| c) _____ | |
| d) _____ | |
| 2. Are these substances harmful? | No Yes |
| | <input type="checkbox"/> <input type="checkbox"/> |
| 3. Dangerous decomposition products when heated? | No Yes |
| If yes, which? _____ | <input type="checkbox"/> <input type="checkbox"/> |

2) Components contaminated by microbiological, explosive or radioactive products/substances will not be accepted without written evidence of decontamination.

| | |
|--|------------|
| D. Legally binding declaration | |
| I / we hereby declare that the information supplied on this form is accurate and sufficient to judge any contamination level. | |
| Name of authorised person (block letters): _____ | firm stamp |
| Date _____ Signatur of authorised person _____ | |