

Chemtech Scientific provides access to this content as a courtesy.
We do not own the content contained in this document.
All rights and credit go directly to its rightful owners.
www.chemtechsci.com
Call us at: 484-424-9415



Sogevac[®] SV630 B - SV750 B

Single-stage, oil-sealed rotary vane pump

Operating instructions GA02319_002_03

Part Numbers :

960 862
960 863
960 865
960 866
960 867
960 869
960 875



Contents

	Page
Important Safety Information	3
1 Description	5
1.1 Principle of operation	5
1.2 Technical characteristics	6
1.3 Ordering Information	14
1.4 Connection fittings	16
1.5 Accessories	18
1.6 SV + WAU combinations	18
1.7 Spare parts	19
1.8 Lubricants	19
2 Transport and Storing	20
2.1 Transport and packaging	20
2.2 Mounting orientation	20
2.3 Storage	20
3 Installation	21
3.1 Mise en place	21
3.2 Connection to system	21
3.3 Electrical connections	25
3.4 Start-up	28
4 Operation	29
4.1 Operation	29
4.2 Switching off / Shutdown	30
4.3 Ultimate pump pressure	30
5 Maintenance	31
5.1 Safety Information	31
5.2 Maintenance Intervals	31
5.3 Oerlikon Leybold Vacuum Service	32
5.4 Maintenance Work	32
6 Troubleshooting	40
7 Spare parts	42
EC Conformance Declaration	52
Declaration of Contamination of Compressors, Vacuum Pumps and Components	53

Safety Information

Important Safety Information

Indicates procedures that must be strictly observed to prevent hazards to persons.

Indicates procedures that must be strictly observed to prevent damage to, or destruction of the product.

Emphasises additional application information and other useful information provided within these Operating Instructions.

The Oerlikon Leybold Vacuum Sogevac® SV630 B - SV750 B has been designed for safe and efficient operation when used properly and in accordance with these Operating Instructions. It is the responsibility of the user to carefully read and strictly observe all safety precautions described in this section and throughout the Operating Instructions. The Sogevac® SV630 B - SV750 B **must only be operated in the proper condition and under the conditions described in the Operating Instructions.** It must be operated and maintained by trained personnel only. Consult local, state, and national agencies regarding specific requirements and regulations. Address any further safety, operation and/or maintenance questions to our nearest office.

Failure to observe the following precautions could result in serious personal injury!

SOGEVAC® pumps are not designed:

- for pumping of aggressive, corrosive, flammable or explosive gases or gases mixtures ;
- for pumping of oxygen or other highly reactive gases with a greater concentration than atmospheric concentration (>20%) ;
- for working in flammable or explosive environment.

For all these cases, special materials must be used. In case of doubt, please contact Oerlikon Leybold Vacuum.

See also the limits of use indicated in the CE declaration of conformity.

Never expose part of the body to the vacuum. There is a danger of injury. Never operate the pump with an open and thus accessible inlet. Vacuum connections as well as oil filling and oil draining openings must not be opened during operation of the pump.

When operating pump is hot and some surfaces could reach a temperature higher than 80°C (176°F). There is a risk of burn by touching.

Depending on the process involved, dangerous substances and oil may escape from the pump. Take the necessary safety precautions !

When working on the pump system always observe the Operating Instructions.

Disconnect the unit from the power supply before starting any work.

Warning

Caution

Note

Warning



Avertissement



Safety Information

Warning



Take appropriate precautions to insure that the pump cannot start.

If the pump has pumped hazardous gases it will be absolutely necessary to determine the nature of the hazard involved and take the appropriate safety precautions.

Observe all safety regulations !

Take adequate safety precautions prior to opening the intake or exhaust port.

Caution

Failure to observe the following precautions could result in damage to the equipment!

Liquid and solid particles must not enter the pump. Install the adequate filters, separators and/or condensers. In case of doubt consult Oerlikon Leybold Vacuum.

The intake line of the pump must never be connected to a device with over atmospheric pressure. Design the exhaust line so that no pressure higher than 1,15 bar abs. (0,15 bar rel.) can occur.

Operating of the pump without oil or operating with incorrect direction of rotation can destroy the pump.

Note

Never use discarded seals. Always assemble using new seals.

Respect the instructions concerning environment protection when discarding used oil or exhaust filters !

The pump must be packaged in such a way that it will not be damaged during shipping, and so that no harmful substances can escape from the package.

We reserve the right to alter the design or any data given in these Operating Instructions. The illustrations are not binding.

1 Description

SOGEVAC® pumps are designed for pumping of inert gases in the range of rough vacuum, between atmospheric pressure and end pressure of the pump.

When removing condensable vapours, a gas ballast valve (or 2) must be installed.

1.1 Principle of operation

The SOGEVAC® SV630 B / SV750 B is a single-stage, oil-sealed rotary vane pump.

The anti-suckback valve, gas ballast valve, exhaust filters, oil feedback circuit, oil cooler and thermal switch are integrated functional elements of the SV630 B. The pump is driven by a foot-mounted motor via four V-belts.

The rotor mounted eccentrically in the pump cylinder has three vanes which divide the pump chamber into several compartments. The volume of each changes periodically with the rotation of the rotor.

As a result of enlargement of the pump chamber that is open in the direction of the intake port, gas is sucked in. The gas passes through the dirt trap and the open antisuckback valve and enters the pump chamber. As the rotor rotates further, the vane separates part of the pump chamber from the intake port. This part of the pump chamber is reduced, and the gas is compressed. At slightly above atmospheric pressure the gas is expelled from the chamber via the exhaust valves.

Oil injected into the pump chamber serves to seal, lubricate and cool the pump.

The oil entrained with the compressed gas is coarsely trapped in the bottom part of the oil casing. Then fine filtering occurs in the 8 integrated exhaust filter elements.

The oil trapped in the exhaust filters is returned to the stator via an oil return line. To prevent gas flowing at atmospheric pressure from the oil reservoir into the intake port, the oil return line is controlled by a float valve.

The oil cycle of the SOGEVAC® SV630 B is maintained by the pressure difference existing between the oil casing (pressure above atmospheric pressure) and the intake port (pressure below atmospheric pressure).

Unintentional venting of the vacuum chamber as well as oil suckback when switching off the pump are prevented by the built-in anti-suckback valve. Nevertheless, the anti-suckback valve does not guarantee the same safety as one valve.

As an additional failsafe device a thermal switch is incorporated ; it measures the temperature in the main oil cycle before the oil is injected into the pump chamber.

Description

Comme mesure de sécurité supplémentaire, il a été prévu en série une sécurité thermique qui contrôle la température dans le circuit principal d'huile de la pompe avant que l'huile soit injectée dans la chambre d'admission.

1.2 Technical characteristics

SV630 B

Technical data		50 Hz	60 Hz
Pumping speed ¹⁾	m ³ . h ⁻¹	640	755
Ultimate partial pressure without gas ballast ¹⁾	mbar	≤ 8.10 ⁻²	≤ 8.10 ⁻²
Ultimate total pressure with 1 gas ballast ¹⁾	mbar	≤ 0,7	≤ 0,7
Ultimate total pressure with 2 gas ballasts ¹⁾	mbar	≤ 2	≤ 2
Water vapour tolerance:	mbar		
■ without gas ballast			
■ with 1 gas ballast ^{1) 3)}		40	50
■ with 2 gas ballasts ^{1) 3)}		60	70
Water vapour capacity:	kg.h ⁻¹		
■ without gas ballast			
■ with 1 gas ballast ^{1) 3)}		17	24
■ with 2 gas ballasts ^{1) 3)}		26	34
Noise level ²⁾	dB (A)	72	75
Type of protection/Isolation		IP 54/F	IP 54/F
Rated rotational speed pump	min ⁻¹	820	1000
Weight (with oil filling)	kg	650	650
Oil capacity min./max.	l	20/23	20/23
Thermal switch (pump)		YES	YES

1) to DIN 28400 and following numbers, with standard gas-ballast

2) operated at the ultimate pressure without gas-ballast, free-field measurement at a distance of 1 m

3) please contact Oerlikon Leybold Vacuum

Description

SV630 B - SV750 B

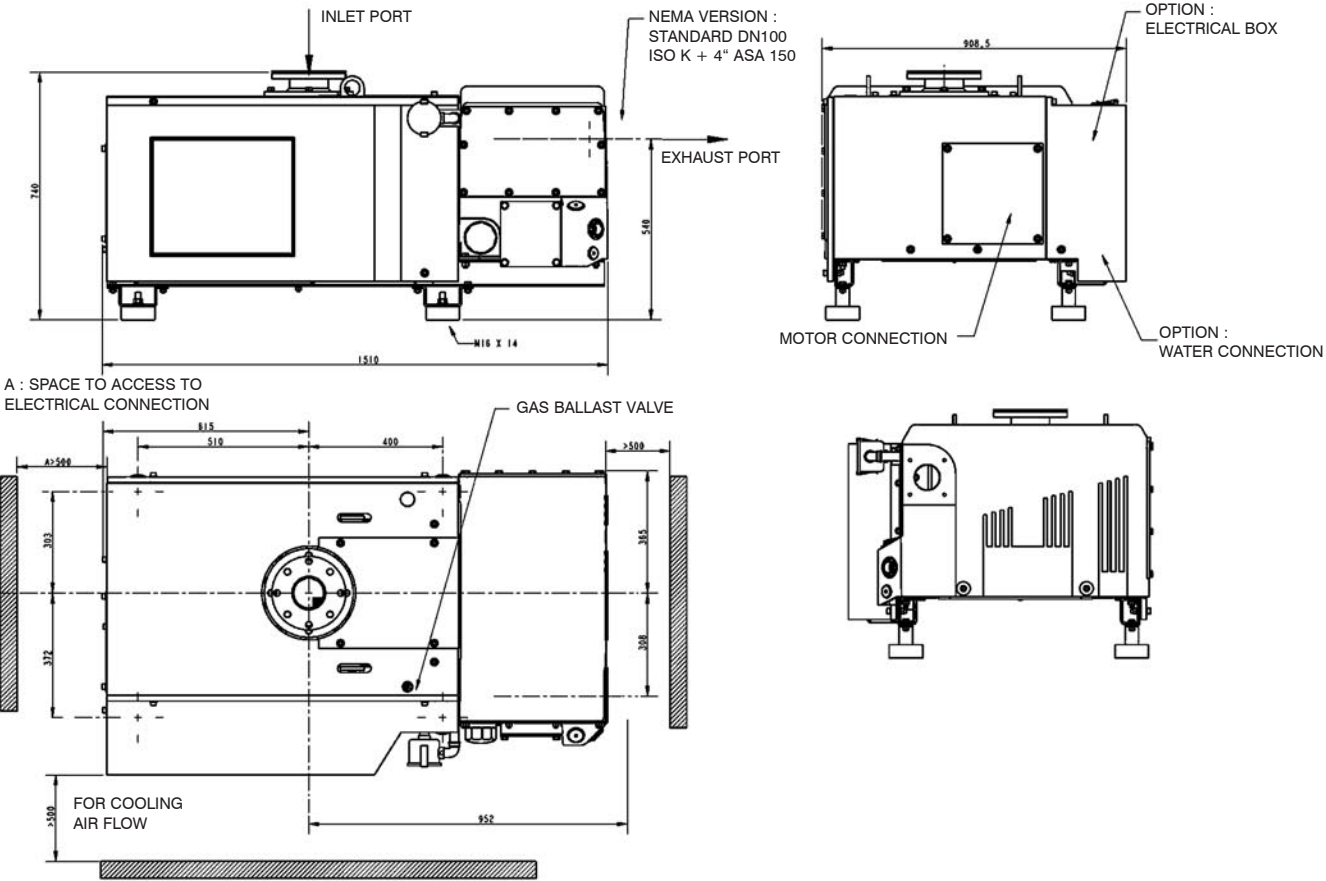

Pumping speeds SV630 B - SV750 B

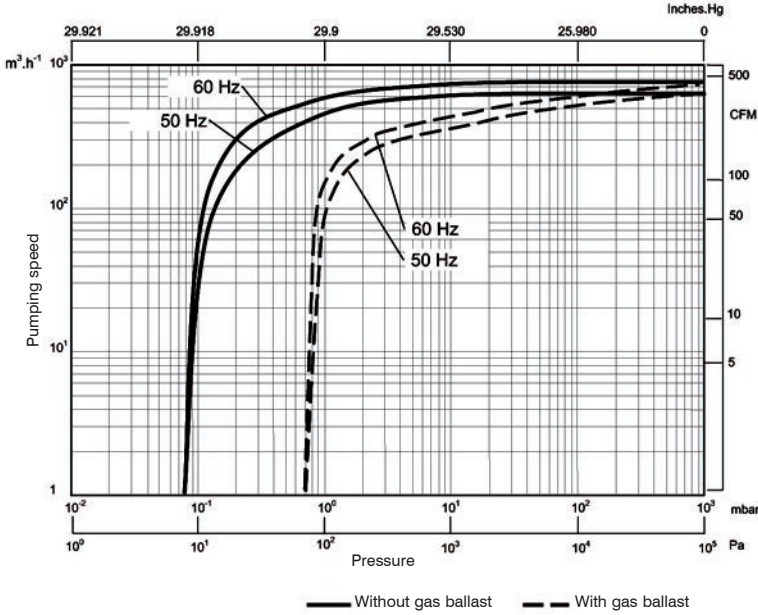

fig. 1

Description

SV630 BF

Technical data		50 Hz	60 Hz
Pumping speed ¹⁾	m ³ . h ⁻¹	640	755
Ultimate partial pressure without gas ballast ¹⁾	mbar	≤ 8.10 ⁻²	≤ 8.10 ⁻²
Ultimate total pressure with 1 gas ballast EM ¹⁾ 24 VDC	mbar	≤ 0,7	≤ 0,7
Ultimate total pressure with 2 gas ballasts EM ¹⁾ 24 VDC	mbar	≤ 2	≤ 2
Antisuckback valve 24 VDC		YES	YES
Water vapour tolerance:	mbar		
■ without gas ballast			
■ with 1 gas ballast ³⁾		25	30
■ with 2 gas ballasts ³⁾		35	40
Water vapour capacity:	kg.h ⁻¹		
■ without gas ballast			
■ with 1 gas ballast ^{1) 3)}		11	14
■ with 2 gas ballasts ^{1) 3)}		15	19
Cooling		H ₂ O	H ₂ O
Thermostatic valve		YES	YES
Water quality	TH (°F)	4 - 8	4 - 8
Water pressure min./max. see § 3.2 for water consumption	bar	2/8	2/8
Noise level ²⁾	dB (A)	72	75
Type of protection/Isolation		IP 54/F	IP 54/F
Rated rotational speed pump	min ⁻¹	820	1000
Weight (with oil filling)	kg	650	650
Oil capacity min./max.	l	20/23	20/23
Thermal switch pump		YES	YES
Thermal switch motor		YES	YES

1) to DIN 28400 and following numbers, with standard gas-ballast

2) operated at the ultimate pressure without gas-ballast, free-field measurement at a distance of 1 m

3) please contact Oerlikon Leybold Vacuum

Description

SV630 BF

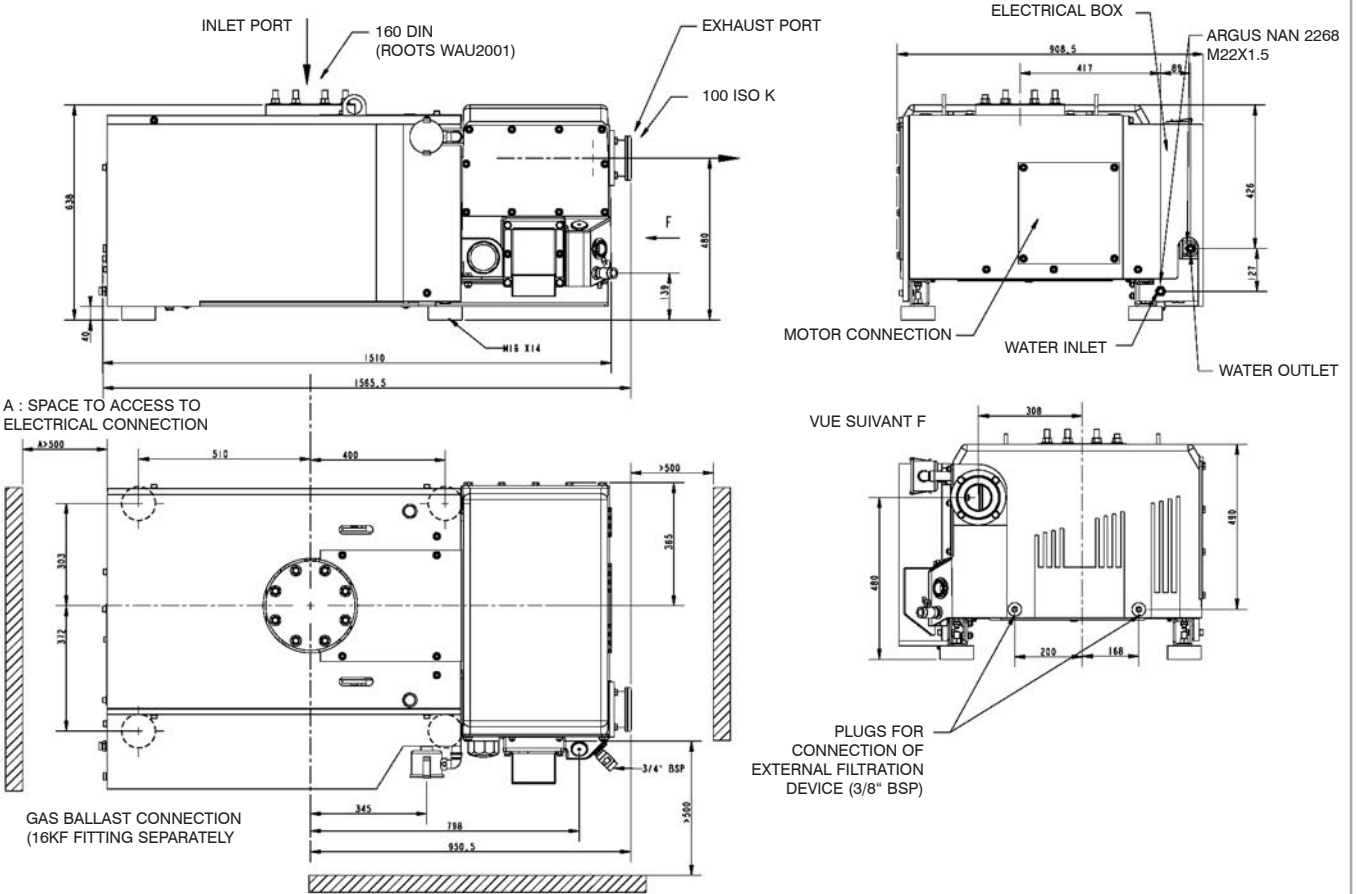

Pumping speeds SV630 BF

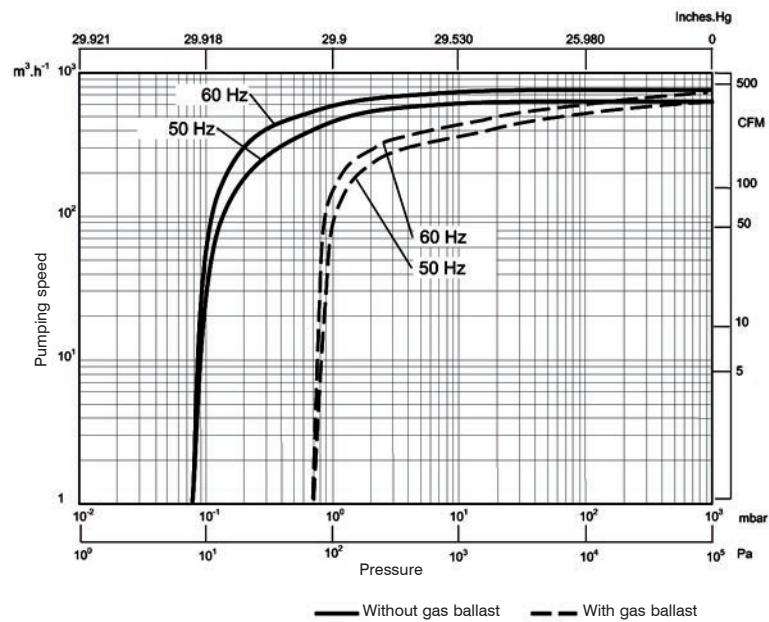

fig. 2

Description

SV750 B

Technical data

50 Hz

Pumping speed ¹⁾	m ³ . h ⁻¹	755
Ultimate partial pressure without gas ballast ¹⁾	mbar	≤ 8.10 ⁻²
Ultimate total pressure with 1 gas ballast standard ¹⁾	mbar	≤ 0,7
Ultimate total pressure with 2 gas ballasts standard ¹⁾	mbar	≤ 2
Water vapour tolerance:	mbar	
■ without gas ballast		
■ with 1 gas ballast ^{1) 3)}		50
■ with 2 gas ballasts ^{1) 3)}		70
Water vapour capacity:	kg.h ⁻¹	
■ without gas ballast		
■ with 1 gas ballast ^{1) 3)}		24
■ with 2 gas ballasts ^{1) 3)}		34
Noise level ²⁾	dB (A)	75
Type of protection/Isolation		IP 54/F
Rated rotational speed pump	min ⁻¹	1000
Weight (with oil filling)	kg	650
Oil capacity min./max.	l	20/23
Intake connection		DN 100 PN 10 100 ISOK
Exhaust connection		option
Oil cooler		LUFT
Thermal switch (pump)		YES
Thermal sensors motor		YES

1) to DIN 28400 and following numbers, with standard gas-ballast

2) operated at the ultimate pressure without gas-ballast, free-field measurement at a distance of 1 m

3) please contact Oerlikon Leybold Vacuum

Description

SV750 B

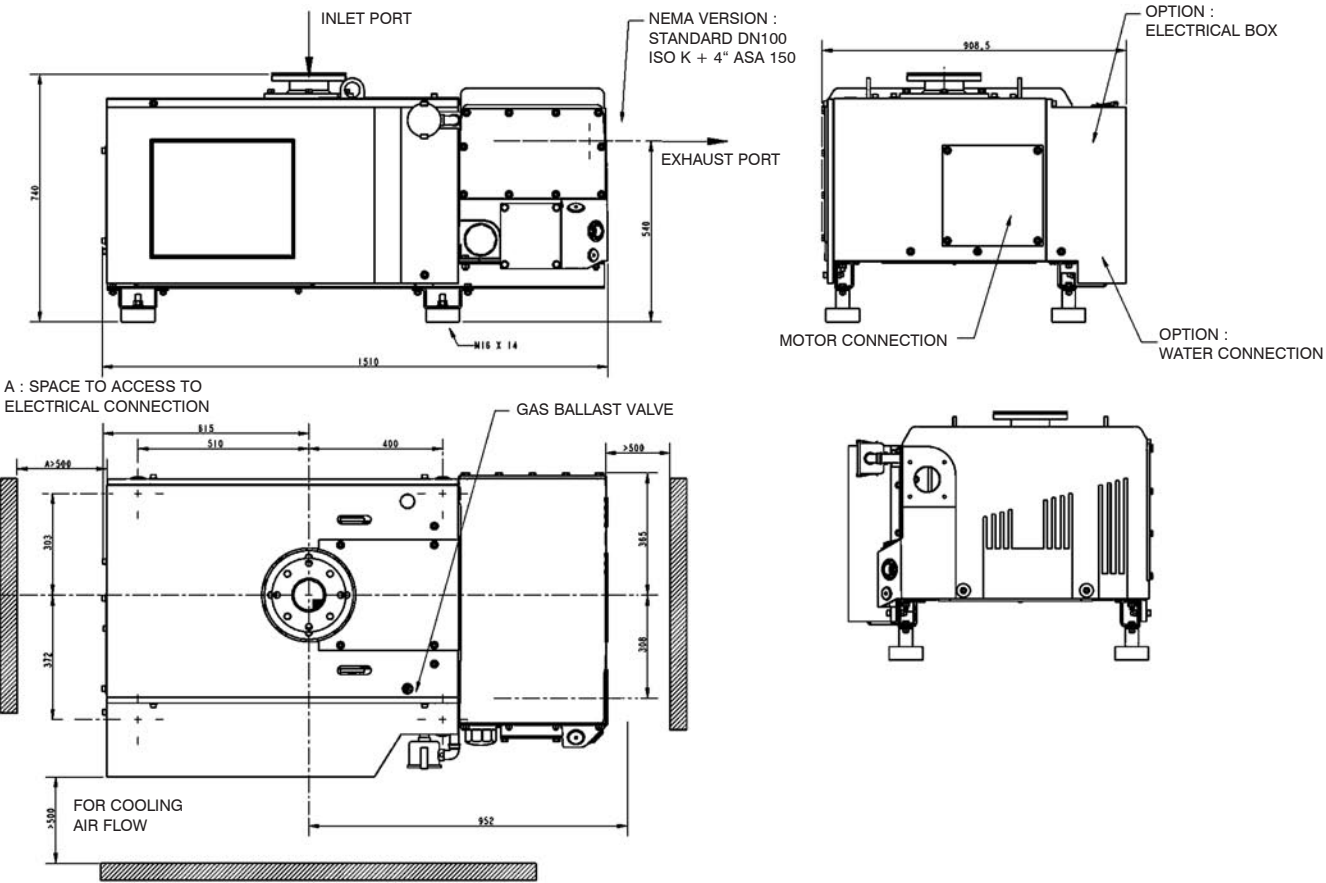

Pumping speeds SV750 B

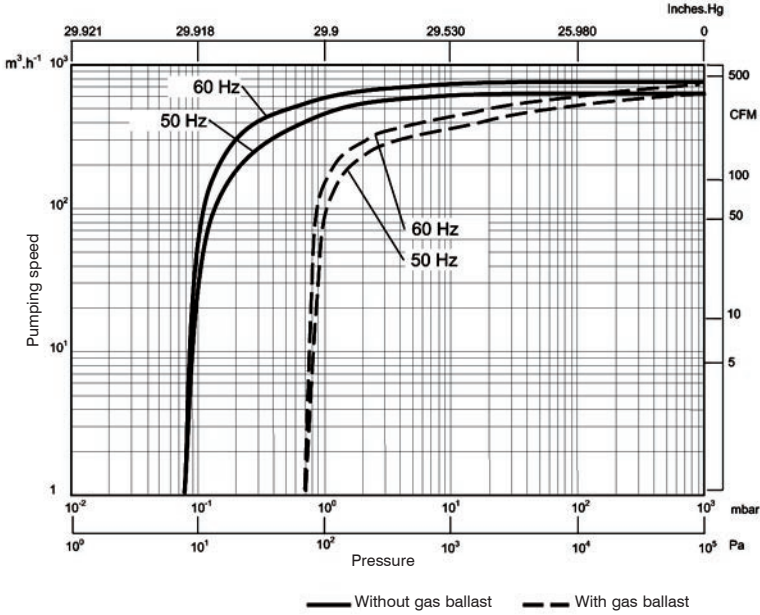

fig. 3

Description

SV630 B US/AIR (60 Hz)

Technical data		60 Hz
Pumping speed ¹⁾	cfm	444
Ultimate partial pressure without gas ballast ¹⁾	Torr	≤ 0.06
Ultimate total pressure with 1 gas ballast standard ¹⁾	Torr	≤ 0.5
Ultimate total pressure with 2 gas ballasts standard ¹⁾	Torr	≤ 1.5
Water vapour tolerance:	Torr	
■ without gas ballast		
■ with 1 gas ballast ¹⁾		37
■ with 2 gas ballasts ¹⁾		52
Water vapour capacity:	qt/hr	
■ without gas ballast		
■ with 1 gas ballast ^{1) 3)}		25
■ with 2 gas ballasts ^{1) 3)}		35
Noise level ²⁾	dB (A)	75
Motor power	hp	25
Type of protection/Isolation		TEFC / F
Rated rotational speed pump	rpm	1000
Weight (with oil filling)	lb	1440
Oil capacity min./max.	qt	21/24
Intake connection		4" ASA 150 / 100 ISOK
Exhaust connection		4" ASA 150 / 100 ISOK
Thermal switch (pump)		YES
Thermal sensors motor		YES

1) to DIN 28400 and following numbers, with standard gas-ballast

2) operated at the ultimate pressure without gas-ballast, free-field measurement at a distance of 1 m

3) please contact Oerlikon Leybold Vacuum

Conversion factors

Different pressure units

Different pumping speed units

	Mbar (millibar)	torr	inches Hg vacuum		m ³ .h ⁻¹	l.s ⁻¹	cfm
1 lb = 0.453 kg	1013	760	0	m ³ . h ⁻¹ = m ³ /h	1	0.278	0.589
1 qt = 0.946 l	400	300	18.12				
1 hp = 0.735 kW	133	100	25.98	l.s ⁻¹ = l/s	3.60	1	2.12 l r.p.m.
= 1 min ⁻¹	4	3	29.80				
1 pouce = 25.4 mm	1	0.75	29.89	cfm (cubic feet per minute)	1.699	0.472	1
	0	0	29.92				

1 atm (atmosphere) = 1013 mbar

1 Pa (pascal) = 0.01 mbar = 10⁻² mbar

1 bar = 1000 mbar

1 torr = 1.33 mbar

Example : 1 m³.H⁻¹ = 0.589 cfm

SV630 BF US (60 Hz)

Technical data		60 Hz
Pumping speed ¹⁾	cfm	444
Ultimate partial pressure without gas ballast ¹⁾	Torr	0.06
Ultimate total pressure with 1 gas ballast EM ¹⁾ 24 VDC	Torr	≤ 0.5
Ultimate total pressure with 2 gas ballasts EM ¹⁾ 24 VDC	Torr	≤ 1.5
Antisuckback valve 24 VDC		OUI
Water vapour tolerance:	Torr	
■ without gas ballast		
■ with 1 gas ballast ³⁾		22,5
■ with 2 gas ballasts ³⁾		30
Water vapour capacity:	qt/hr	
■ without gas ballast		
■ with 1 gas ballast ^{1) 3)}		15
■ with 2 gas ballasts ^{1) 3)}		20
Cooling		H2O
Thermostatic valve		YES
Water quality	TH (°F)	4 - 8
Water pressure min./max.	PSI	29/114
Noise level ²⁾	dB (A)	75
Motor power	HP	25
Type of protection/Isolation		TEFC / F
Rated rotational speed pump	rpm	1000
Weight (with oil filling)	lb	1440
Oil capacity min./max.	qt	21/24
Intake connection		DIN 160
Exhaust connection		DN 100 ISOK
Thermal switch Pump		YES
Thermal switch Motor		YES

1) to DIN 28400 and following numbers, with standard gas-ballast

2) operated at the ultimate pressure without gas-ballast, free-field measurement at a distance of 1 m

3) please contact Oerlikon Leybold Vacuum

Description

1.3 Ordering Information

SV630 B

Options	960 862	960 863	960 865
Intake connection	DN 100 PN10 DN 100 ISO-K	DN 100 PN10 DN 100 ISO-K	4" ASA 150 / DN 100 ISO-K
Exhaust connection	Option	Option	4" ASA 150 / 100 ISO-K
Gas ballast	Manual	Manual	Manual
Anti-suckback valve	Standard	Standard	Standard
Mains voltage	200 V \pm 10%, 50 Hz 18,5 kW JIS	380 V \pm 5%, 50 Hz 400 V \pm 10%, 50 Hz 690 V \pm 10%, 50 Hz 415 V \pm 5%, 50 Hz 15 kW	400 V \pm 10%, 50 Hz 25 hp NEMA
	200 V \pm 10%, 60 Hz 18,5 kW	440 V \pm 5%, 60 Hz 460 V \pm 10%, 60 Hz 18 kW	230 V \pm 10%, 60 Hz 460 V \pm 10%, 60 Hz 25 hp
CTP thermistors	YES	NO	NO

SV630 BF

Options	960 866	960 867	960 869
Intake connection	DIN 160	DIN 160	DIN 160
Exhaust connection	DN 100 ISO-K	DN 100 ISO-K	DN 100 ISO-K
Gas ballast	24 VDC	24 VDC	24 VDC
Anti-suckback valve	24 VDC	24 VDC	24 VDC
Mains voltage	200 V \pm 10%, 50 Hz 18,5 kW JIS	380 V \pm 5%, 50 Hz 400 V \pm 10%, 50 Hz 690 V \pm 10%, 50 Hz 415 V \pm 5%, 50 Hz 15 kW	400 V \pm 10%, 50 Hz 25 hp NEMA
	200 V \pm 10%, 60 Hz 18,5 kW	440 V \pm 5%, 60 Hz 460 V \pm 10%, 60 Hz 18 kW	230 V \pm 10%, 60 Hz 460 V \pm 10%, 60 Hz 25 hp
CTP thermistors	YES	YES	YES

SV750 B

Options

960 875

Intake connection	DN 100 PN10 DN 100 ISO-K
Exhaust connection	Option
Gas ballast	Manual
Anti-suckback valve	Standard
ains voltage	380 V \pm 5%, 50 Hz 400 V \pm 10%, 50 Hz 690 V \pm 10%, 50 Hz 415 V \pm 5%, 50 Hz 18,5 kW
CTP thermistors	YES

Description

1.4 Connection fittings

Rep.	Specification	Size	Cat. Nr.
1	PVC tube	Ø 90	711 18 329
2	Adapter for tube	DN 90 - 100 PN 10	711 18 362
3	Elastic coupling	Ø 100 - PN 10	711 18 342
4	Adapter flange	DN 100 PN 10-4" BSP	711 18 372
5	Adapter flange	DN 100 PN 10-3" BSP	711 18 370
6	Adapter flange	4" BSP M/DN 90	711 18 017
7	Roots Adapter	Roots 1000	9 714 32 340
	Roots Adapter	Roots 2000	9 714 32 350
	Adapter (not represented)	DN100 PN10 100 ISO K	711 18 336
	Screwsset*		714 12 440
8	O Ring (NBR)	DN 110x5	712 42 882
9	Centering Ring + O Ring (NBR)	100 ISO K, 100 PN 10	711 18 391
10	Elbow 90°	DN 100 PN 10	711 18 284
11	Filter (Paper)	F 400 - 630 P	951 71
	Filter (Metal)	F 400 - 630 M	711 27 163
	Filter (Activated charcoal)	F 400 - 630 CA	711 27 162
	Filter (Polyester)	F 400 - 630	711 27 164
12	Hand valve	DN 100	711 30 116
13	EP valve	DN 100	Option**
14	Adapter flange	Ø 100 PN 10 - NFE 29222	711 18 351
15	Adapter flange	DN 100 PN 10 - 100 ISO K	711 18 383
16	RBall valve	1/2" BSP M/F	711 30 113
17	Manometer	Ø 1/2" BSP M	951 92
18	Elbow 90°	100 ISO K	887 26
19	Set of 4 clamps for ISO K flanges	M 10 x 24	26 701
20	Centering ring	100 ISO K AL/NBR	26 808
21	Filtre (Paper)	100 ISO K	951 72
	Filtre (Metal)	100 ISO K	711 27 167
	Filter (Activated charcoal)	100 ISO K	711 27 166
	Filtre (Polyester)	100 ISO K	

Description

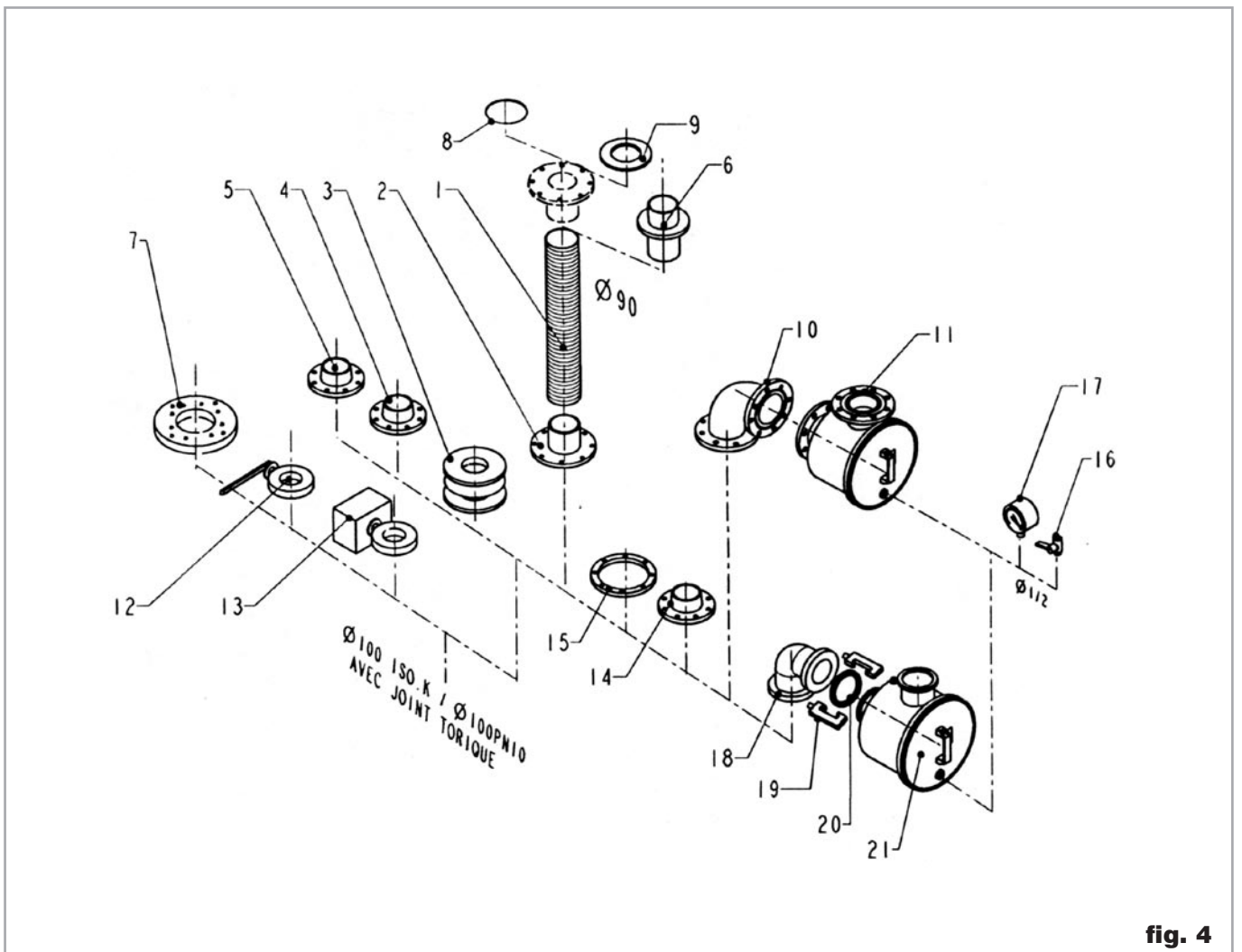

fig. 4

Description

1.5 Accessories

Specification	Size	SV630 B - SV750 B	SV630 BF
		Cat. Nr.	Cat. Nr.
Oil drain tap		711 30 114	Standard
EM gas ballast kit	24 V DC	9 714 38 170	9 714 38 170
Gas ballast standard (2 nd) (manual)		9 714 46 490	9 714 46 490
2 EM gas ballasts	24 V DC		9 714 38 160
2 gas ballasts (manual)		9 714 38 340	9 714 38 340
Exhaust filter gauge (manometer)		951 94	951 94
Oil level monitor		9 714 25 760	9 714 25 760
Thermal switch	Standard	9 714 30 630	9 714 40 000
Inlet kit 100 ISOK		Standard	9 714 30 550
Water cooling with thermostatic valve		On request	Standard
Oil filter by-pass		712 36 390	712 36 390
Exhaust filter over pressure switch		712 22 360	712 22 360

Operation of pump is insured with accessories of Oerlikon Leybold Vacuum:
mounting any other accessory will engage the responsibility of user concerning
operation of pump.

1.6 SV + WAU combinations

Specification	Size	SV630 B - SV750 B	SV630 BF
		Cat. Nr.	Cat. Nr.
Adapter Roots 1000		9 714 32 340	9 714 32 340
Adapter Roots 2000		9 714 32 350	Standard

1.7 Spare parts

		SV630 B	SV630 BF	SV750 B
Specification	Size	Cat. Nr.	Cat. Nr.	Cat. Nr.
Oil filter standard		714 05 310	714 05 310	714 05 310
Exhaust filter (Quantity per pump)		9 714 31 120 8	9 714 31 120 8	9 714 31 120 8
Set of seals	FPM	9 714 37 310	9 714 37 310	9 714 37 310
Repair set		9 714 37 320	9 714 37 320	(1)
Module kit		9 714 37 330	9 714 37 330	(1)
Service kit		9 714 37 340	9 714 37 340	9 714 37 340
Inlet filter element				
■ paper		710 35 242	710 35 242	710 35 242
■ metal		710 37 734	710 37 734	710 37 734
■ charcoal		710 37 724	710 37 724	710 37 724
■ polyester		712 61 508	712 61 508	712 61 508

1) Upon request

1.8 Lubricants

The SOGEVAC® SV B pumps should be run with mineral oils for vacuum pumps with low viscosity according to ISO category VG77. The Oerlikon Leybold Vacuum oil GS77 (He-200 in the US) fulfills these specifications.

GS77 Oil : (He-200)	Conditioning	Reference
	2 l	711 17 773
	5 l	711 17 774
	20 l	711 17 775
	200 l	711 17 779

You may use other special lubricants adapted to the applications. Please consult us.

Transport and Storing

2 Transport and Storing

2.1 Transport and packaging

SOGEVAC® vacuum pumps pass a rigorous operating test in our factory and are packaged to avoid transport damages.

Please check packaging on delivery for transport damages.

Packing materials should be disposed off according to environmental laws or re-cycled. These operating instructions are part of the consignment.

The connection ports are blanked off by plastic protective caps or self-adhesives. Take these caps or self-adhesives away before turning on the pump.

The SV630 B, SV750 B, have the GS77 (He-200) mineral oil filled in.

2.2 Mounting orientation

See required space on drawings in paragraph 1.2.

Pumps which have been filled with oil must only be moved in the upright position (horizontally). Otherwise oil may escape. The angle of slope may not be over 10° max. Avoid any other orientations while moving the pump.

Only use the lifting lugs which are provided on the pump to lift the pump with the specified lifting devices.

Make sure that these have been installed safety. Use suitable lifting equipment. Make sure that all safety regulations are observed..

2.3 Storage

Before stocking the pump for a long time put it back in its original condition (blank off inlet and exhaust ports with the shipping seals, drain the oil) and store the pump in a dry place at room temperature.

Until the pump is put back in to service again, the pump should be stored in a dry place, preferably at room temperature (20 °C - 168 °F). Before taking the pump out of service, it should be properly disconnected from the vacuum system, purged with dry nitrogen and the oil should be exchange too. Drain the water from the cooling circuit (See § 3.2). The gas ballast must be closed and if the pump is to be shelved for a longer period of time is should be sealed in a plastic bag together with a desiccant (Silicagel).

If the pump has been shelved for over one year, standard maintenance must be done and the oil must be exchanged too before the pump is put in to service once more.

We recommend that you contact the service from Oerlikon Leybold Vacuum.

Caution

3 Installation

It is essential to observe the following instructions step by step to ensure safe start-up. Start-up may only be conducted by trained specialists.

The standard pump is not suitable for installation in explosion hazard areas ATEX. Please contact us, if you are planning such an application. Before installing the pump you must reliably disconnect it from the electrical power supply and prevent the pump from running up inadvertently.

Observe all safety regulations.

3.1 Installation

The SOGEVAC®s can be set up on any flat, horizontal surface. Under the four feet, there are metric threaded holes (M16x1.4) for securing the pump.

The oil level cannot be read properly if the pump is tilted and lubrication may be affected.

The pump's ambient temperature should be between 12°C (55°F) and 40°C (104°F). By modifying the pump or changing the oil type, the pump can be run at a other ambient temperature. Please consult us.

To ensure adequate cooling of the pump, leave enough space at the air intake and exhaust points, and for access and maintenance (see Fig. 1-2-3 for SV630 B/SV750 B)

Make sure to keep the air intake of the motor clean.

3.2 Connection to system

The standard pump is not suitable for installation in explosion hazard areas ATEX. Please contact us, when you are planning such an application.

Intake Side

- Pump should be connected to inlet line without any tension. Use flex lines or pipe unions in your inlet and exhaust lines so that they can be easily removed for pump maintenance.
- The maximum pressure at the inlet may not exceed atmospheric pressure (about 1013 mbar). Never operate the pump in the presence of over pressures at its intake.
- Type of materials used for mounting of pipings should take care of pumped gases. It is the same for its tightness.

The pump is equipped with an inlet flange 100 ISO K/DN 100 PN 10 (SV630 B / SV750 B) or DIN 160 roots adapter (SV630 BF). Using suitable connecting elements (see § 1.4) the pump can be connected to the vacuum system.

The cross-section of the intake line should be at least the same as the one for the intake port. If the intake line is too narrow, it reduces the pumping speed.

If the process gas contains dust, it is absolutely essential to install a dust filter in addition to the dirt trap supplied (see §1.4).

Warning



Caution

Caution

Installation

We recommend to install the dust filter horizontally. This ensures that when removing the filter no particles fall into the intake port.

When pumping vapors, we recommend installing condensate traps on the intake and exhaust sides

The intake must be installed in such a way to avoid condensates flowing into the pump.

Exhaust Side

The SOGEVAC® pumps have integrated exhaust filters which, even at a high gas throughput, trap the oil mist and guarantee exhaust gas free of oil mist. If the exhaust filters are clogged, the by pass opens at 1.5 bar, (absolute pressure), and the filters are bypassed. As a result, the proportion of oil in the exhaust gas as well as the pump's oil consumption will rise. Installing new exhaust filters will correct this problem. (See § 5.4).

Check in the individual case whether an line is necessary and/or prescribed. Volatile substances will pass through the filter. Depending on the process gas, we recommend connecting an exhaust line ; this is always necessary when the exhaust gases are dangerous.

Note

The maximum exhaust pressure must neither exceed 1.15 bar absolute (0.15 bar relative), nor fall under atmosphere pressure minus 15 mbar.

Exhaust flanges

■ The SV630 B (Euro-version) and the SV750 B are not equipped with outlet flange (only hole Ø 80). An outlet pipe can be connected through accessory : Exhaust kit DN 100 PN10, 100 ISO K : Cat. Nr. 9 714 38 540.

■ SV630 BF is in standard equipped with outlet flange DN 100 ISO K.

The cross-section of the exhaust line should be at least the same as the pump's exhaust port. If the exhaust line is too narrow, overpressure or overheating may occur in the pump.

Before installing the exhaust line, remove the exhaust-flange plate and ensure that the exhaust demister(s) are secured tightly in place. They sometimes loosen during shipping and installation. A loose demister results in exhaust smoke during start-up and operation. Install the exhaust line with a downward slope to prevent condensate from flowing back into the pump. If this is not possible, we strongly recommend installing a condensate trap.

Caution

Never operate the pump with a blocked or restricted exhaust line. Before start-up, ensure that any blinds or similar shut-off devices in the exhaust line on the pressure side are opened and that the exhaust line is not obstructed.

Exhaust pipe material must be resistant to pumped gases.

Water cooling

The SOGEVAC® pumps are equipped, in standard for the SV630 BF and as an option for the SV630 B/SV750 B, with a water cooling system and a thermostatic valve. Depending on the local regulations, the cooling water needed may not be taken from the drinking water mains and max. water temperatures must be observed. The water cooling connection is made by an ARGUS type 1/2» x M22 - 150 adapter.

The thermostatic valve regulates the cooling water throughput, and so the pump temperature. The valve is set in standard on position 1.

Normally, the thermostatic valve should be set somewhere in the range from 1 to 3. Thermostat setting 1 (valve fully open) produces a low operating temperature of the pump, and setting 3 a high one.

Pumping on vapors requires setting on position 3.

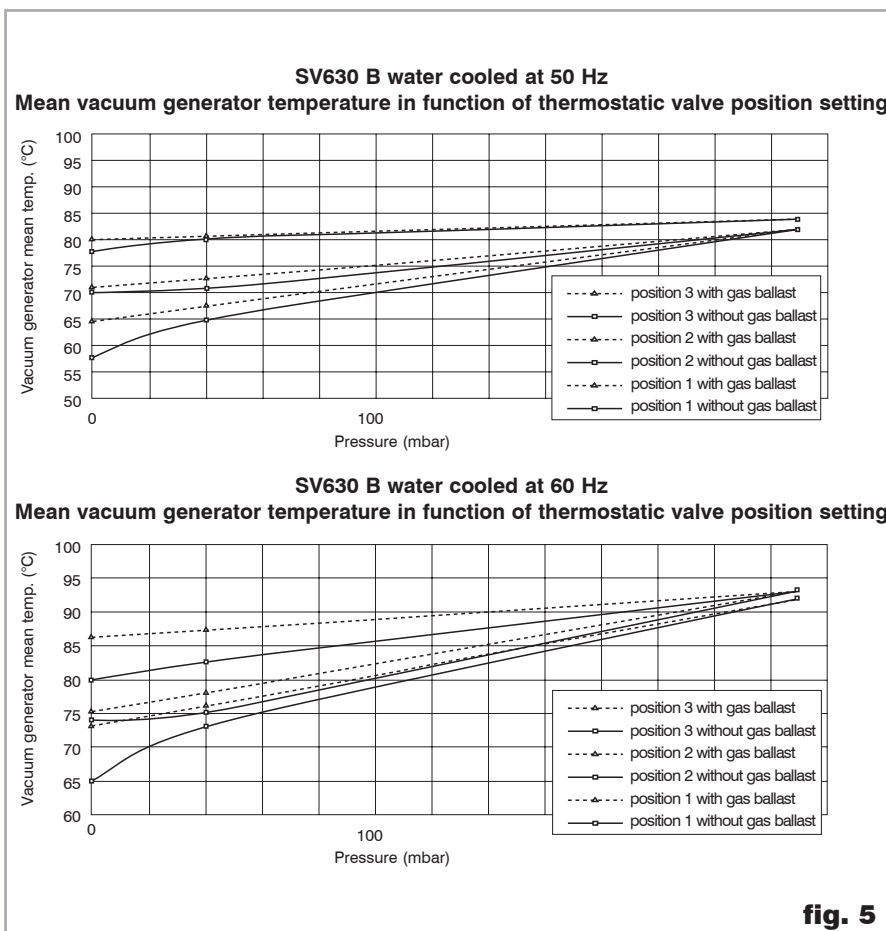

Installation

Position thermo. valve		50 Hz				60 Hz			
		Ultimate pr.	40 mbar	Ultimate pr. and gas ballast	250 mbar and gas ballast	Ultimate pr.	40 mbar	Ultimate pr. and gas ballast	250 mbar and gas ballast
1	ΔT water (°C)	7	10	9	13	8	11	11	15
	δ H ₂ O (l/h)	643	667	668	656	690	668	676	68
	P (kW)	6	7	7	10	7	9	8	12
2	ΔT water (°C)	52	17	18	12	27	14	10	14
	δ H ₂ O (l/h)	99	307	292	726	181	511	718	730
	P (kW)	4	6	6	10	6	8	8	12
3	ΔT water (°C)	45	32	35	17	38	23	34	14
	δ H ₂ O (l/h)	78	158	139	462	129	276	185	703
	P (kW)	4	6	6	9	6	7	7	11

ΔT water (°C) : Cooling water temperature increase

δ H₂O (l/h) : Cooling water flow

P (kW) : Absorbed power by cooling water

Water cooling

	TH (°F)	0°	4°	8°	12°	20°
Water quality			Corrosion (water too soft)	Service area		Incrusting water (deposit of scale)
Carbonat content	PPm	0	30	9	160	300
			Corrosion (water too soft)	Service area	Incrusting water	Very incrusting water
	PH	0	5	7,5		
			Corrosion (water too soft)	Service area	Incrusting water	

Do not use deionised cooling water.

To clean the heat exchanger : it is recommended to clean at least twice a year the water circuit.

For that, dismantle the exchanger from the pump. Chemical cleaning is the most efficient, with dilute hydrochloric acid solution (5 to 10%) then neutralize with hexamethylethyrene tetramine at 0.2 %. For a 1 mm coat of scale, leave acting the acid during about 30 min.

The system must be open during the operations, so the product gases can escape. Rinse copiously with water after neutralization.

Proceed in an open and well ventilated place.

Observe the safety regulations given by the manufacturer of the product you are using.

Observe the regulations for the treatment and the disposal of chemical products.

Observe the relevant environmental regulations.

Warning



Draining of the water-cooling circuit (before transport, long time storage, winter time).

Remove the cover Item 55 and place a water recovery pan under the heat exchanger and unscrew the plug Item 57.

The heat exchanger water will drain.

To drain completely the heat exchanger:

- Remove the water outlet hose and close the water outlet with a plug.
- Remove the water inlet hose
- Connect a compressed air supply in place of plug Item 57 and blow.

Attention, water will be evacuated through the water inlet connection.

Reassemble in the reverse sequence.

Note

3.3 Electrical connections

Ensure that incoming power to the pump is off before wiring the motor or altering the wiring.

Warning

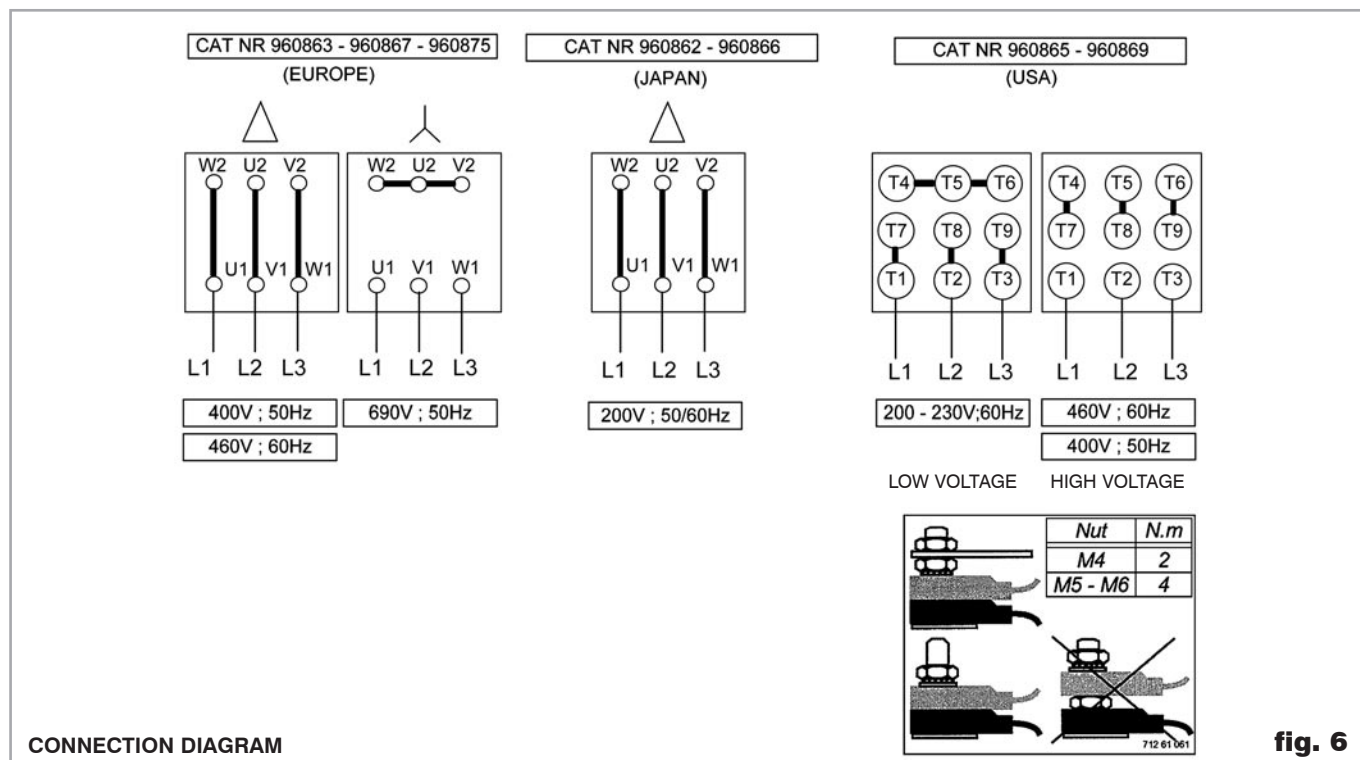

fig. 6

Electrical connection work must only be carried out by a qualified electrician in accordance with the applicable safety rules, see IEC 60204-1.

Connect the pump's motor to the right supply voltage via the connections in the junction box (see fig. 6). The relevant safety rules require the use of a suitable motor protection switch. Set the switch in accordance with the rating on the motor nameplate.

Installation

Warning



If any security switch or electrical defect cuts out the pump, re-start-up of the pump has to be possible only manually.

Motor protection device

To protect the motor windings against a variety of operational malfunctions, the motor of the SV630 BF is fitted with protection devices.

CTP thermistors to IEC 60034-1 and DIN 44081/440823 are temperature - dependent, semi-conductor devices embedded in the motor windings.

Working principle

Non-linear variable resistors. It is recommended to connect them to the control circuit. CTP thermistors ensure a good protection against the overheating of the motor.

The pump is designed for direct starting even under load conditions, i.e. the pump can be switched on against vacuum in the intake port.

Note

After connecting the motor and after every time you alter the wiring, check the direction of rotation. Refer to the marking on the motor. During the check, the intake port should be open. If the direction of rotation is wrong, oil may be ejected out the intake port. (The vacuum system may be pressurised).

For the check, switch on the motor briefly. If it starts up with the wrong direction of rotation, switch it off immediately and interchange two phases of the connection. It is recommendable to check the direction of rotation with a phasesequenece indicator.

Caution

Prolonged running of the motor in the wrong direction of rotation will damage the pump !

Oil thermal Switch

Connection has to be made in the junction box (see fig. 7).

Breaking power on resistive circuit 250 VAC / 10 A.

To be serial wired with the coil of motor's contactor. Use an auxiliary relay.

The pump is switched off once a certain oil temperature (115 °C/239 °F) is exceeded. It is also possible to connect an alarm system. (see fig. 7).

Motorization

European versions :

A 50/60 Hz motor is mounted in standard on the SV630 B and SV630 BF.

Voltages :

400 V $\pm 10\%$ at 50 Hz

460 V $\pm 10\%$ at 60 Hz

A motor working only at 50 Hz is mounted in standard on the SV750.B

Voltage :

400 V $\pm 10\%$ at 50 Hz

Japan versions :

A JIS 50/60Hz motor is mounted in standard on the SV630 B and SV630 BF.

With CTP sensors.

Voltage :

200 V $\pm 10\%$ at 50 Hz and 60 Hz

US versions:

A NEMA motor is mounted in standard on the SV630 B and SV630 BF. With CTP sensors.

Voltages :

400 V $\pm 10\%$ at 50 Hz

230 V/460 V $\pm 10\%$ at 60 Hz

Particularities SV630 BF

The pump SV630 BF is in standard equipped with options which have to be connected before starting up the pump.

Gas Ballast (EM Valve)

Normally closed (Power supply 24 V DC $\pm 10\%$)

To be wired in connection box (see fig. 7).

Electromagnetic valve (antisuck-back valve)

Normally open

To be supplied in 24 V DC as soon as the pump starts. Shut down power supply as the pump stops.

If several pumps with EM antisuck-back valves are operated in parallel, there is a risk in case of V belt failure that the pump oil is sucked out. This can be prevented by using a valve on the intake port controlled by a motor $\cos \varphi$ controlling device.

The rotation detector P/N 9 714 48 780 can be used as well as a retrofit or on new pumps.

Installation

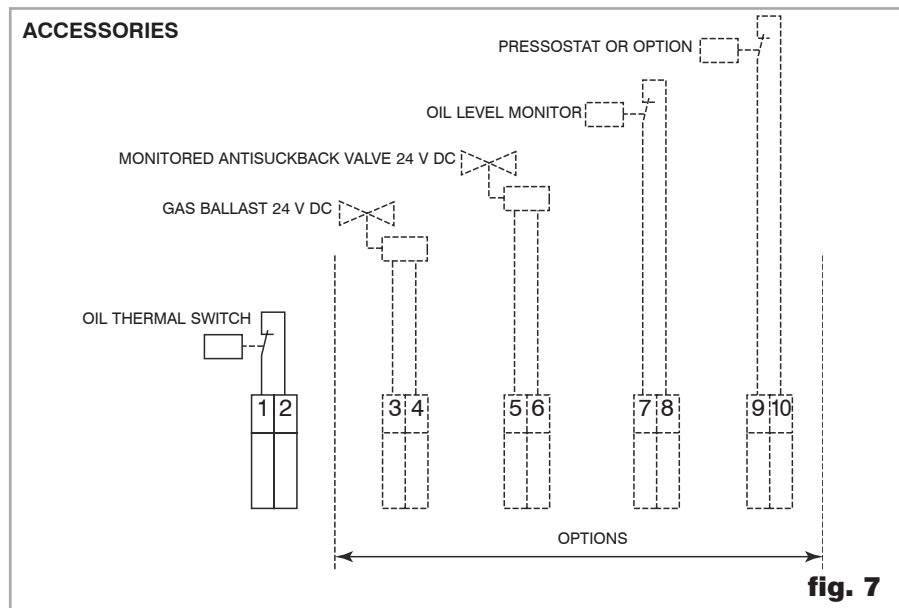

fig. 7

The electrical options installed on the pump are wired and have their respective connection terminals installed in the connection box.

Option : Oil level monitor

Reed contact	Power supply (max.)	Breaking power on resistiv circuit
AC 0.5 A	25 V	50 VA
DC 1.0 A	60 V	50 W

To be serial wired with the coil of motor's contactor (the pump stops in case of missing oil).

You must use imperatively an auxiliairy relay.

3.4 Start-up

The pumps are supplied with the necessary oil filling in ready-to-use condition. Always verify proper oil level before operating the pump.

The pump is designed for fail-safe start-up at temperatures over 12°C (55°F) (as per PNEUROF).

If local regulations provide a WYE-DELTA starting connect the pump to the system so that it can start loadfree, i.e. at atmospheric pressure in the intake port. If the vacuum system is not to be vented further measures will be necessary, e.g. a starting valve can be mounted. Please contact us in this case.

Caution

The signals of the oil level switch and exhaust filter over pressure switch must be delayed (timer) on the pump switch-on for approx. 1 minute.

SV630 BF is equipped with :

- Electromagnetic gas ballast valve 24 V DC. Connection has to be made on junction box (see fig. 7).
- Antisuckback valve driven by EM valve DC. Connection has to be made on junction box (see fig. 7).

4 Operation

4.1 Operation

To avoid overloading the motor, do not start the pump more than 6 times within one hour.

If more than 6 starts per hour are necessary keep the pump running and mount a valve which opens and closes into the intake line.

Take note of warning labels on the pump.

Pumping of non-condensable gases

If the pump system contains mainly non condensable gases, the SV630 B should be operated without gas ballast.

If the composition of the gases to be pumped is not known and if condensation in the pump cannot be ruled out, run the pump with gas ballast valve open in accordance with section below.

Pumping of condensable gases and vapors

With the gas ballast valve open and at operating temperature, the SOGEVAC® SV630.B can pump pure water vapor up to the values indicated in the Technical Data.

The gas ballast valve is opened by a screwdriver. The running noise of the pump is slightly louder if the gas ballast valve is open. Before pumping vapors ensure that the SV630 B has warmed up for approx. 30 min. with closed intake line and with open gas ballast valve.

Don't open the pump to condensable vapors until it has warmed to operating temperature ; pumping process gas with a cold pump results in vapors condensing in the oil.

For processes with a high proportion of condensable vapors, the intake line should be opened only slowly after reaching the operating temperature.

One sign of condensation of vapors in the pump is a rise of the oil level during operation of the pump.

When vapors are pumped, the pump must not be switched off immediately after completion of the process because the condensate dissolved in the pump oil may cause changes or corrosion. To prevent this, the pump must continue to operate with open gas ballast valve and closed intake port until the oil is free of condensate. We recommend operating the pump in this mode for at least 30 min. after completion of the process.

In cycle operation, the pump should not be switched off between the cycles but should continue to run with gas ballast valve open and intake port closed (if possible via a valve). Power consumption is minimal when the pump is operating at ultimate pressure.

Once all vapors have been pumped off from a process (e. g. during drying), the gas ballast valve can be closed in order to improve the ultimate pressure.

Warning



Caution

Note

Caution

Note

Operation

4.2 Switching off / Shutdown

The intake port of the SOGEVAC® SV630 B contains an anti-suckback valve which closes the intake port when the pump is switched off, thus maintaining the vacuum in the connected apparatus and preventing oil from being sucked back into the apparatus. The valve's functioning is not impaired by gas ballast operation.

If the pump has to be shutdown, drain the oil flush out the pump with fresh oil and fill in the required amount of clean oil (see § 5.4). Close the connection ports. Special preservation or flushing oils do not need to be used.

Caution

When the pump has been switched off due to over heating, initiated by the motor or its temperature detector, the pump must be cooled down to the ambient temperature, and must only be switched on again manually after having eliminated the cause.

In order to prevent the pump from running up unexpectedly after a mains power failure, the pump must be integrated in to the control system in such a way that the pump can only be started by a manually operated switch. This applies equally to emergency cut-off switches.

In case of switching processes in connection with a pump which has warmed up under operation conditions, the pump must then not be directly switched on again.

4.3 Ultimate pump pressure

If the values specified in the Technical Data are not reached in the apparatus, measure the ultimate pressure directly at the pump's intake port after disconnecting the pump from the apparatus.

The ultimate pressure of non-condensable gases (partial pressure of air) can only be measured with a compression vacuum gauge or a partial pressure gauge. Precise measurements can only be obtained with calibrated instruments.

Upon initial start-up, after prolonged idle periods or after an oil change, it takes a while until the pump reaches the specified ultimate pressure. The pump has to attain its operating temperature, and the pump oil has to be degassed. We recommend operating the pump initially with the gas ballast valve open.

The ultimate pressure depends on the pump temperature and the pump oil used. The best ultimate pressures can be obtained at a low pump temperature and by using the recommended oil types.

5 Maintenance

5.1 Safety Information

Observe all safety regulations.

All work must be done by suitably trained personnel. Maintenance or repairs carried out incorrectly will affect the life and performance of the pump and may cause problems when filing warranty claims.

Never mount used seals ; always mount new seals.

5.2 Maintenance Intervals

The intervals stated in the maintenance schedule are approximate values for normal pump operation. Unfavourable ambient conditions and/or aggressive media may significantly reduce the maintenance intervals.

Maintenance job	Frequency	Section
Check the oil level	Daily	A
Check the oil condition	Depends on process	B
1st oil change	After 150 h of operation	C
Subsequent oil changes	Every 1000 h of operation or 3 months	C
Replace the oil filter	At each oil change	C
Replace the exhaust filter d'échappement	If oil mist at exhaust or annually	D
Clean the dirt trap	Monthly	E
Check the anti-suckback valve	Annually	F
Clean oil cooler	Annually	
Clean filter of gasballast	Monthly	G
Checking the float valve	When changing the exhaust filters	H
Replacing the exhaust valves	*	I
Replacing the pump module	*	J
Disassembling and reassembling the pump module	*	K
Control belts	6 months	L

* in case of specific pump servicing

To simplify the maintenance work we recommend combining several jobs.

Warning



Caution

Maintenance

Contamination

5.3 Oerlikon Leybold Vacuum Service

Whenever you send us in equipment, indicate whether the equipment is contaminated or is free of substances which could pose a health hazard. If it is contaminated, specify exactly which substances are involved. You must use the form we have prepared for this purpose.

Form

A copy of the form has been reproduced at the end of these Operating Instructions: "Declaration of Contamination for Compressors, Vacuum Pumps and Components". Another suitable form is available from www.oerlikon.com → Oerlikon Leybold Vacuum Systems → Documentation → Download Documents.

Attach the form to the equipment or enclose it with the equipment.

This statement detailing the type of contamination is required to satisfy legal requirements and for the protection of our employees.

We must return to the sender any equipment which is not accompanied by a contamination statement.

Caution

The pump must be packaged in such a way that it will not be damaged during shipping, and so that no harmful substances can escape from the package.

When disposing of used oil, please observe the relevant environmental regulations.

5.4 Maintenance Work

Checking the oil

A. Oil level

The pump's oil level during operation must always be between the middle and top edge of the oil-level glass (164). When necessary, switch off the pump and add the correct quantity of oil.

High oil consumption often indicates that exhaust filters are clogged (See 5.4 - D).

The oil level should be checked at least once a day.

B. Oil Condition GS77

Normally the oil is clear and transparent. If the oil darkens, it should be changed.

If gases or liquids are dissolved in the oil, the result is a deterioration of the ultimate pressure, the oil can be degassed by allowing the pump to run for about 30 min. with the intake port closed and the gas ballast valve open.

To check if oil should be changed, drain some oil via the oil-drain plug (5) into a beaker or similar container with the pump switched off but still at operating temperature.

Depending on the process involved, dangerous substances may escape from the pump and oil. Take the appropriate precautions.

Observe the safety regulations.

C. Oil Change, Replacing the Oil Filter (if installed)

Tool required :

■ oil filter key (Ref. No. 710 73 532)

Always change the oil when the pump is switched off but still at working temperature.

If there is a risk of the oil being polymerized by the connected process, change the oil immediately after operation of the pump.

Pump when operating is hot and some surfaces could reach a temperature higher than 80° C (176 °F).

There is a risk of burn by touching. Take note of the warning labels on the pump.

Unscrew the oil-drain plug (5) and let the used oil drain into a suitable container.

Observe the safety regulations.

When the flow of oil slows down, screw the oil drain plug back in, briefly switch on the pump (max. 10s) and switch it off. Remove the oil drain plug again and drain the remaining oil.

Unscrew the oil filter (168). Take a new oil filter, moisten its gasket with oil and screw it in manually.

Reinsert the oil-drain plug.

Unscrew the oil-fill plug (122) and fill the pump with fresh oil up to the bottom edge of the oil level glass, run the pump for a short time and then change the oil again.

Use suitable oil only (see Section 1.8).

Depending on the process involved dangerous substances may escape from the pump and oil. Take the appropriate precautions.

Observe the safety regulations.

Never mount used seals. Always mount new seals.

When disposing of used oil please observe the relevant environmental regulations !

Warning



Warning



Caution

Warning



Note

Maintenance

D. Replacing the exhaust filters and checking the by-pass

Tools required :

- tubular box wrench 16 mm.

When the exhaust filter elements are clogged, the integrated by-pass opens and the filters are bypassed. Oil mist at the exhaust, and/or high oil consumption are signs that the exhaust filters are clogged.

The exhaust filters must be replaced more often if subjected to increased oil cracking products at high operating temperatures and/or aggressive media.

Remove the cover (22) with gasket (106). Remove the exhaust deflector (162) by unscrewing the bolt (9).

Remove both demister support units (165) by unscrewing the nuts (11).

The exhaust filters (167) can be removed individually.

Check also the float valve (172). See § 5.4 - H.

Plug new exhaust filters (167) into the oil casing (160).

Insert carefully the demister support units (165) over the new exhaust filters (167) threaded bars (M6) and compress slightly the demister springs.

Tighten the demister support units (165) and the exhaust deflector (162). If necessary mount a new seal (106) and mount the cover (22).

Note

When disposing of used oil please observe the relevant environmental regulations !

E. Cleaning the dirt trap

Tools required :

- Open-jaw or box wrenches 10 mm, 17 mm.

A wire-mesh filter is located in the pump's intake port (43 or 67) to act as a dirt trap for impurities. It should be kept clean at all times in order to avoid reduction of the pumping capacity.

For this purpose, disconnect the intake line, remove the dirt trap from the intake port and rinse it in a suitable vessel using a solvent. Then dry it with compressed air. If the dirt trap is defective, replace it.

The cleaning intervals depend on requirements. If large amounts of abrasive materials occur, a dust filter should be fitted into the intake line (see § 1.4).

Caution

Never mount used seals ; always mount new seals.

F. Checking the anti suckback valve

SV630 B Standard version - SV750 B

Tools required :

- Tubular box wrench 19 mm.

First remove the intake line and the intake flange (42 or 67).

Remove the 4 screws and take off the intake port.

Remove the anti-suckback valve (103 and 105), the spring and the gasket. Clean all parts and check that they are in perfect condition ; if not, replace them.

If the anti-suckback valve closes too early, carefully compress the spring slightly. The top edge of the valve should be about 1 mm away from the top side of the intake port.

Reassemble in the reverse order.

Never mount used seals ; always mount new seals.

Caution

SV 630 BF

Anti-suckback valve is driven by a EM Valve 24 V DC.

G. Cleaning the gas ballast intake filter

When the pump operates with open gas ballast valve, clean the filter (127) once a month.

Release the clips on the gas ballast filter. Clean the filter using a suitable solvent. Then dry it. Reassemble in the reverse sequence.

H. Checking the float Valve

Tools required :

- Tubular box wrench SW16.
- Alen keys 4,6.

If the pressure does not fall below approx. 5 mbar (4 Torr) during pump operation, check the tightness of the float valve (172).

Remove the cover (22) by unscrewing the nuts (11) and remove the seal (106).

Remove the exhaust deflector (162) by unscrewing the bolt (9).

Remove the clip (173) and pull out the float valve (172).

Take off the gasket, clean the nozzle, check the tightness of the float valve.

Check the gaskets of the float-valve and replace them if required.

Reassemble the float-valve in reverse sequence.

Tighten the demister support units (165) and the exhaust deflector (162). If necessary mount a new seal (106) and mount the cover (22).

Maintenance

Warning

Note

Depending on the process involved, dangerous substances may escape from the pump and oil. Take the appropriate precautions.

Observe the safety regulations.

Never mount used seals ; always mount new seals.

When disposing of used oil please observe the relevant environmental regulations !

I. Replacing the exhaust valves

Required tools:

- Tubular box wrench SW16.

Remove the hood (48) by unscrewing the screws (26).

Remove the rubber mounts (44) and the screws (9).

Remove the cover (22) and the gasket (106).

By removing the nuts (11), it is possible to dismount the valve stop and valve plates (107, 108 & 109).

Replace these elements if required.

Reassemble the valve stop and valve plates (107, 108 & 109) in reverse sequence.

Warning

Note

Depending on the process involved, dangerous substances may escape from the pump and oil. Take the appropriate precautions.

Observe the safety regulations.

Never mount used seals ; always mount new seals.

When disposing of used oil please observe the relevant environmental regulations !

J. Replacing the pump module

Fully assembled pump modules are available under Ref. Nos. :
SV630 B / SV 630 BF: 9 714 37 330, SV 750 B: upon request

Consult Oerlikon Leybold Vacuum.

Depending on the process involved, dangerous substances may escape from the pump and oil. Take the appropriate precautions.

Observe the safety regulations.

Never mount used seals ; always mount new seals.

When disposing of used oil please observe the relevant environmental regulations !

Warning

Note

K. Disassembling and reassembling the pump module

Consult Oerlikon Leybold Vacuum.

Depending on the process involved, dangerous substances may escape from the pump and oil. Take the appropriate precautions.

Observe the safety regulations.

Never mount used seals ; always mount new seals.

When disposing of used oil please observe the relevant environmental regulations !

Warning



Note

L. Checking and tightening the V-belts

Tools required :

- Key 19 and 24.

Take off the hood (55 or 15).

Loosen the nuts (66) and (23) x 2. Loosen the push rod (82).

Remove the V belts.

Reassemble in reverse sequence.

Stretch the V-Belts with the following method:

V-belt tension meter

This tension meter ref. 971437840 is a tool designed to check and re-tighten the v-belts

It is made of two sliding pipes with a graded spring inside.

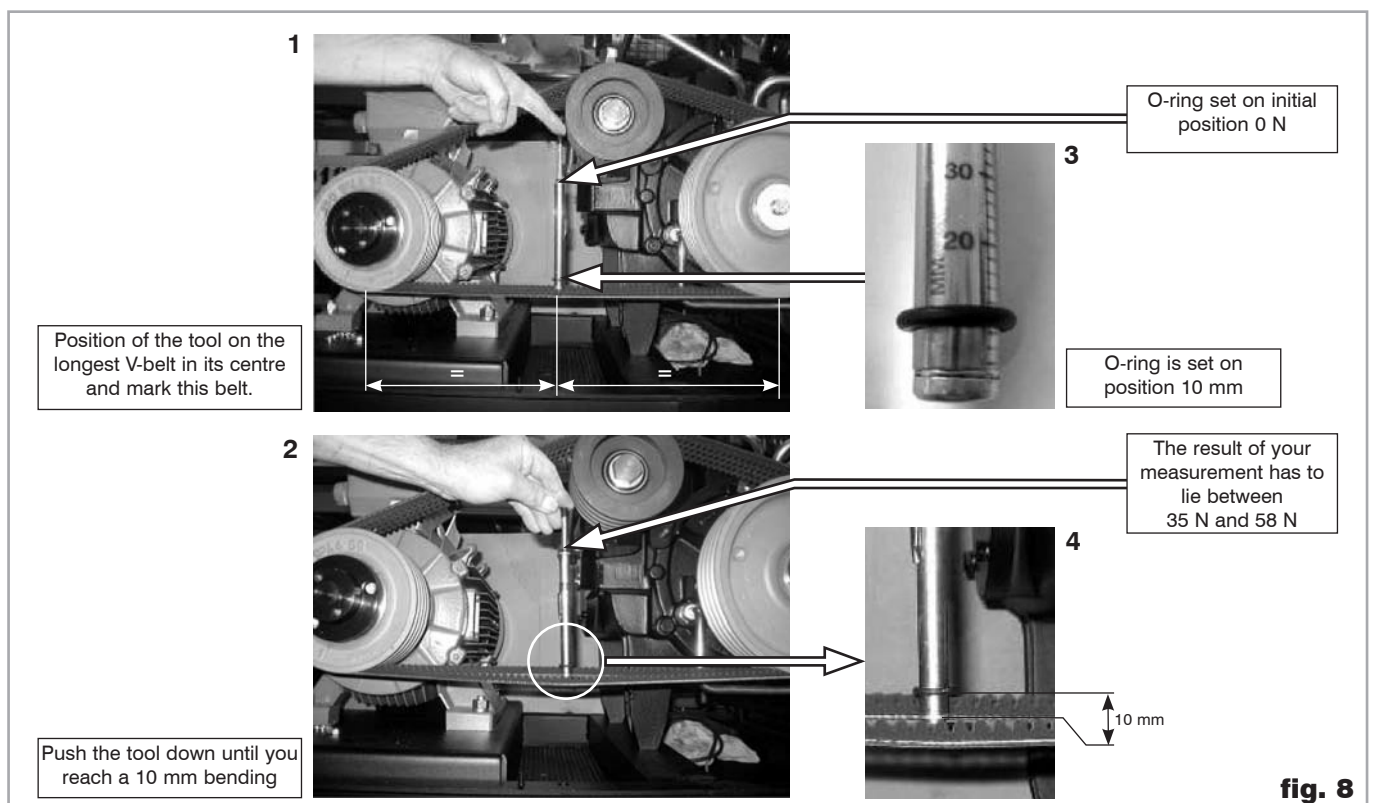

Maintenance

How to use this v-belt tension meter :

- Set the first o-ring at 10 mm on the millimeter scale, as shown figure 8.1, picture 4, and the other o-ring on position 0 on the Newton scale.
- Install the tension meter as shown on picture 3 – figure 8, in the middle, half-way between the v-belt contacts point of the v-belts and the two pulleys.
- Push the Newton scale's black rubber down in order to reach a 10 mm bending of the v-belt (pictures 2 and 4).
- Check the result of your measurement. Tighten the belt tightener to reach the value given in table below.

The stretching of the V-belts can also be checked with a frequency meter:

- Position the tool on the longest V-belt in its centre and mark this belt.
- Place the frequency meter between the motor and generator pulleys, 10 mm above the belts.
- Strike the belt and read the frequency (Hz). Refer to the table below for the rated value.

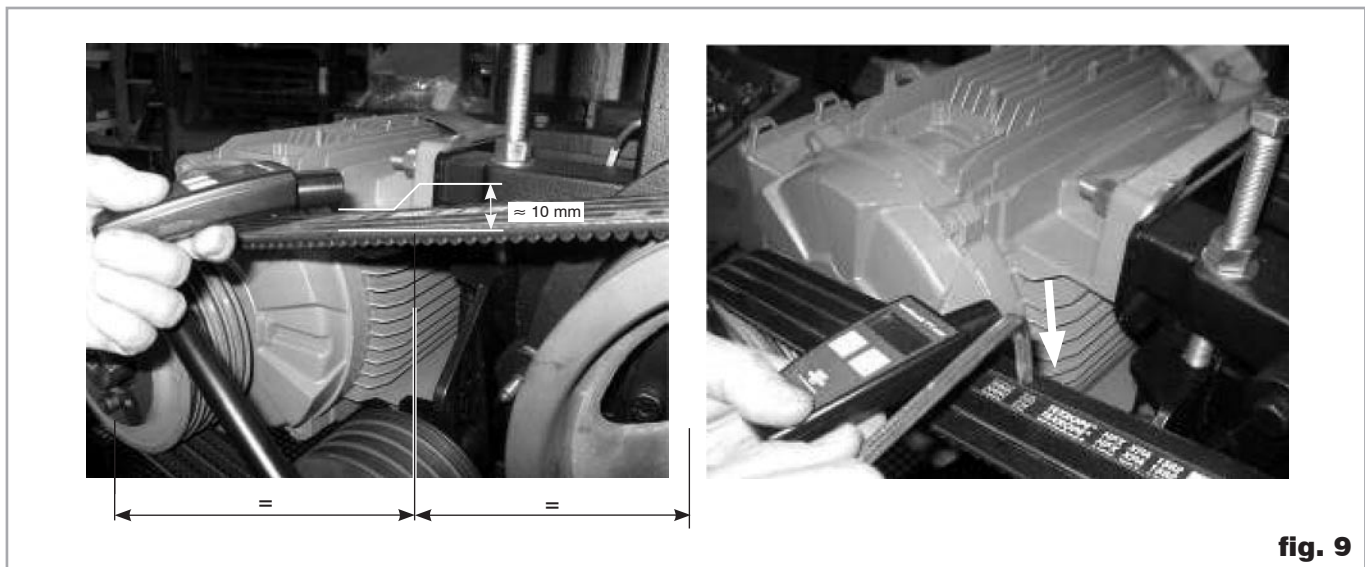

fig. 9

Tightening values of the notched V-belts

Pump	Belts L (mm)	Pin	Before run-in		Re-tightening (after 10 to 24 h) (1)		Regular check (≈6 months or 3000 h.) Value under which a re-tension is necessary. *	
			Force F (N)	Frequency f (Hz)	Force F (N)	Frequency f (Hz)	Force F (N)	Frequency f (Hz)
SV630 B	1500	9 714 30 590	50	mini 69 maxi 71	45	mini 64 maxi 66	35	58
SV630 B USA/JPN	1532	9 714 37 640	50	mini 69 maxi 71	45	mini 64 maxi 66	35	58
SV750 B	1582	9 714 33 170	50	mini 65 maxi 68	45	mini 61 maxi 63	35	58

* Re-tighten with values given in column (1)

Measure always on the same belt.

ATTENTION: Do not untighten a belt if the measurement is over the value in column (1). Do not change the V-belt tension.

M. Lubricating the bearings

The SOGEVAC® pumps SV630 B, SV630 BF and SV750 B are equipped with separate grease-lubricated bearings. In normal operation the permanent-lubricated bearings are provided for 30 000 hours of maintenance-free operation.

With increased thermal load, i. e. continuous operation at high intake pressures, gas ballast operation, it is advisable to check the bearings at shorter intervals. To do so, remove the rear and front covers (97 and 136).

Test the bearing grease. If the grease is resinified, clean the bearings and change the grease.

Use high-temperature grease (ref. N° 711 17 700).

Grease quantity per bearing :

Bearing (94)	9 714 25 960	40 cm ³ ou 45 g
Bearing (139)	714 03 880	60 cm ³ ou 65 g

Troubleshooting

6 Troubleshooting

Fault	Possible cause	Remedy	Reference section *
Pump does not start.	Pump is connected incorrectly.	Connect the pump correctly.	3.3
	Motor protection switch incorrectly set.	Set motor protection switch properly.	3.3
	Operating voltage does not match motor.	Replace the motor.	
	Motor is malfunctioning.	Replace the motor.	
	Oil temperature is below 12°C (54°F).	Heat the pump and pump oil or use different oil.	1.8
	Oil is too viscous.	Use appropriate oil grade.	5.4-C
	Exhaust filter / exhaust line is clogged.	Replace the filter or clean the exhaust line.	3.4-D
Pump does not reach ultimate pressure.	Power transmission by V-belts is impaired.	Tighten or replace the V-belts.	5.4-L
	Pump is seized up	Repair the pump.	5.4-M
	Measuring technique or gauge is unsuitable.	Use correct measuring technique and gauge.	4.3
	External leak	Repair the pump.	
	Float valve does not close.	Repair the valve.	5.4-I
	Anti-suckback valve is malfunctioning.	Repair the valve.	5.4-F
	Inadequate lubrication due to:		
	■ unsuitable or contaminated oil,	Change the oil (degas it, if necessary).	5.4-C
	■ clogged oil filter,	Replace the oil filter.	5.4-C
	■ clogged oil lines.	Clean the oil casing.	
Vacuum lines are dirty.	Clean vacuum lines.		
Pump is too small.	Check the process date; replace the pump, if necessary.		
Pumping speed is too low.	Dirt trap in the intake port is clogged.	Clean the dirt trap ; Precaution : install a dust filter in intake line.	5.4-E/1.2/3.2
	Exhaust filter is clogged.	Install new filter elements.	5.4-D
	Connecting lines are too narrow or too long.	Use adequately wide and short connecting lines.	3.2
	Anti-suckback valve is hard to open.	Check spring free length.	
After switching off pump under vacuum, pressure in system rises too fast.	System has a leak.	Check the system.	
	Anti-suckback is malfunctioning.	Repair the valve.	5.4-F
Pump gets too hot	Cooling air supply is obstructed.	Set pump up correctly.	3.1
	Cooler is dirty.	Clean the cooler.	
	Ambient temperature is too high.	Set pump up correctly.	3.1
	Process gas is too hot.	Change the process.	
	Oil level is too low.	Add oil to reach the correct oil level.	5.4-C
	Oil is unsuitable.	Change the oil.	5.4-C
	Oil cycle is obstructed.	Clean or repair the oil lines.	
	Exhaust filter / exhaust line is obstructed.	Replace the exhaust filter, clean the exhaust line.	5.4-D
Pump module is no longer usable.	Replace the pump module.	5.4-K	

Troubleshooting

Fault	Possible cause	Remedy	Reference section *
Oil in intake line or in vacuum vessel.	Oil comes from the vacuum system.	Check the vacuum system.	
	Anti-suckback valve is obstructed.	Clean or repair the valve.	5.4-F
	Sealing surfaces of anti-suckback valve are damaged or dirty.	Clean or repair the intake port and valve.	5.4-F
Pump's oil consumption too high, oil mist at exhaust.	Oil level is too high.	Drain the excess oil.	5.4-C
	Exhaust filters are clogged or damaged.	Replace the filters.	5.4-D
	Nozzle of float valve is clogged.	Check the valve, clean the nozzle.	5.4-I
Oil is turbid.	Oil level is too high.	Drain the excess oil.	5.4-C
	Condensation.	Degas the oil or change the oil and clean the pump. Precaution : open the gas ballast valve or insert a condensate trap.	4.1/5.4-B
		Clean the gas ballast intake filter.	5.4-G
Pump is excessively noisy.	Oil level is very low (oil is no longer visible).	Add oil.	5.4-C
	Oil filter is clogged.	Change the oil and filter.	5.4-C
	Large vacuum leak in system.	Repair vacuum leak.	5.4-L
	Power transmission by V-belts is impaired.	Tighten or replace the V-belts.	5.4-M

* Reference section : This column refers to the section in the Operating Instructions that contains the applicable repair information.

Never mount used seals. Always mount new seals.

Spare parts

7 Spare parts

To guarantee safe operation of the Oerlikon Leybold Vacuum vacuum pump, only original spare parts and accessories should be used. When ordering spare parts and accessories, always state pump type and serial number. You can find part numbers in the spare parts list.

Consumables and main spare parts kits for SOGEVAC® pumps are usually available on stock at Oerlikon Leybold Vacuum's service centers. The list of these parts is given here after and in the spare parts table where the contents of each kits is detailed.

- Oil filter (on some models)
- Exhaust demisters
- Oil GS 77 (Special oils please refer to the specific notice of the pump or contact Oerlikon Leybold Vacuum).
- Service kit
- Set of seals
- Repair kit

We recommend to use these kits which have been defined to allow an optimal maintenance or repair. individual spare parts may need longer delivery time.

Spare parts

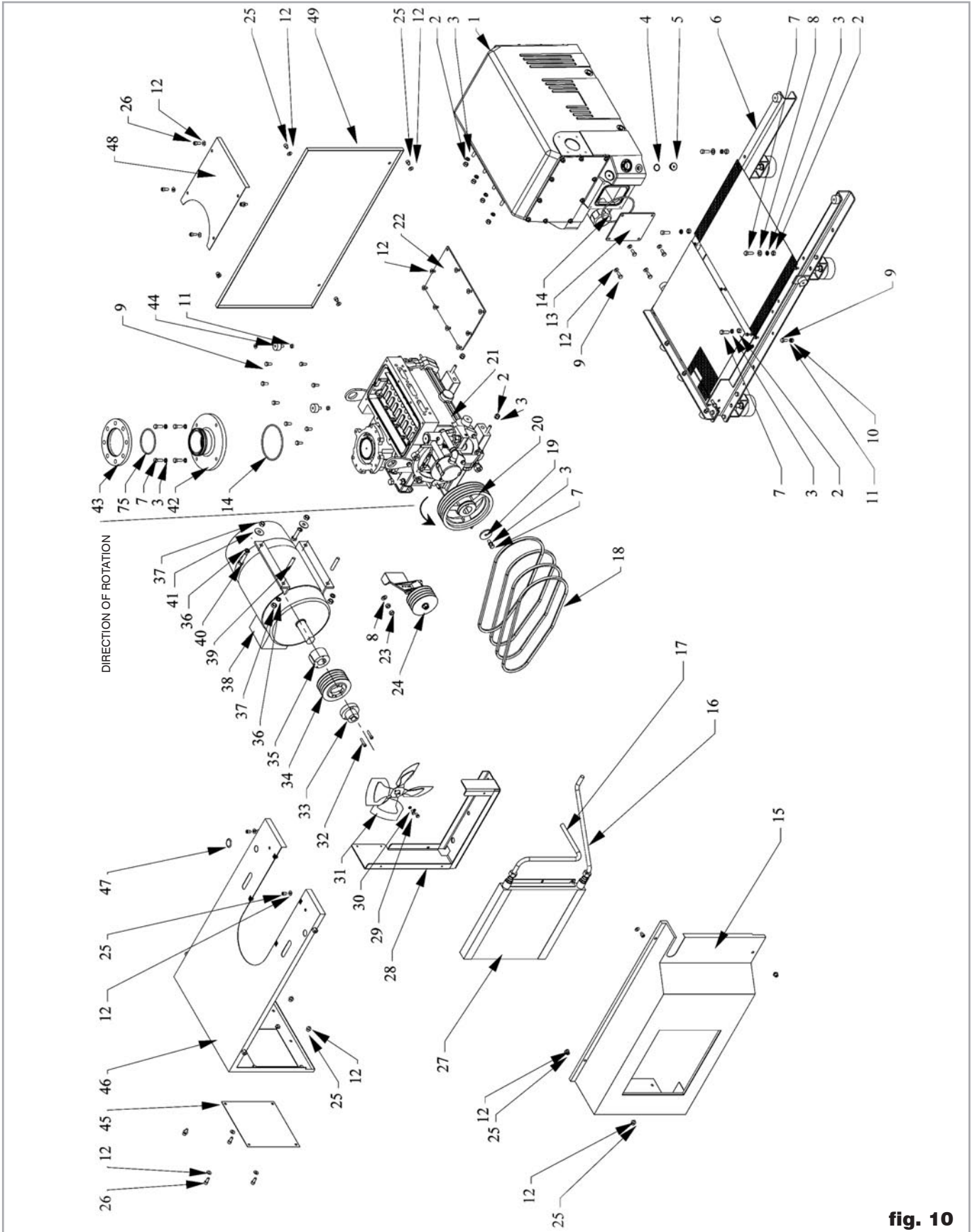

fig. 10

Spare parts

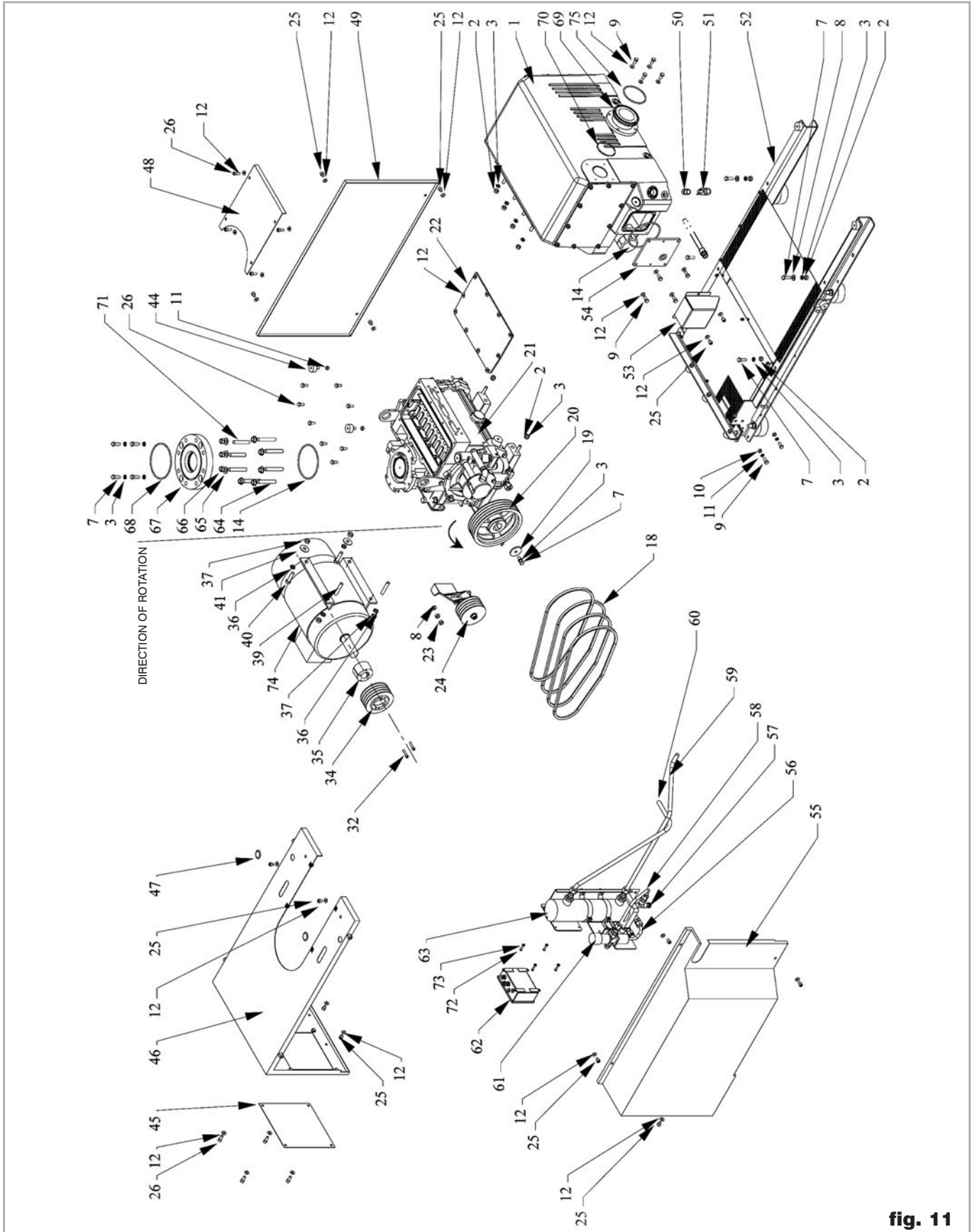

fig. 11

Spare parts

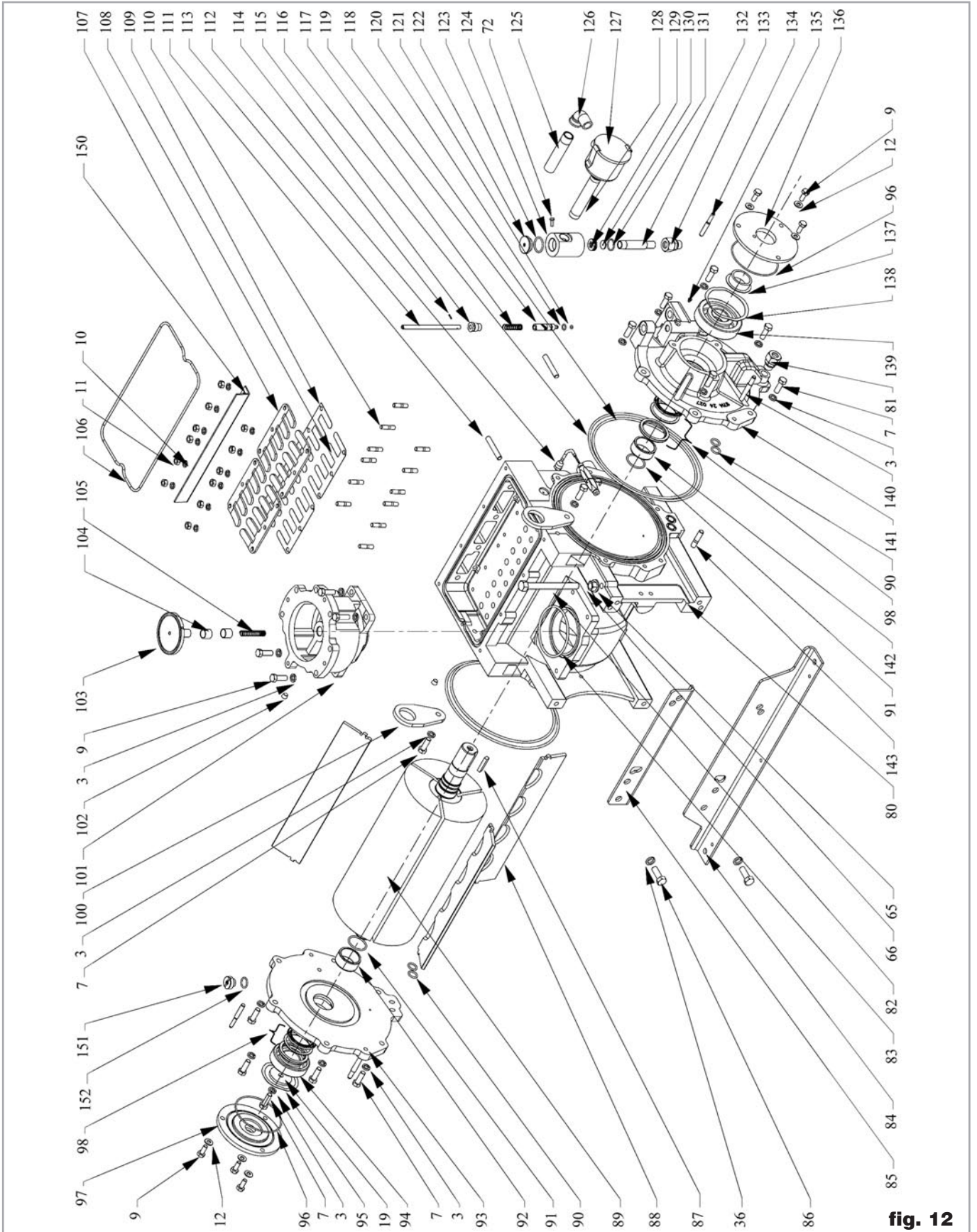

fig. 12

Spare parts

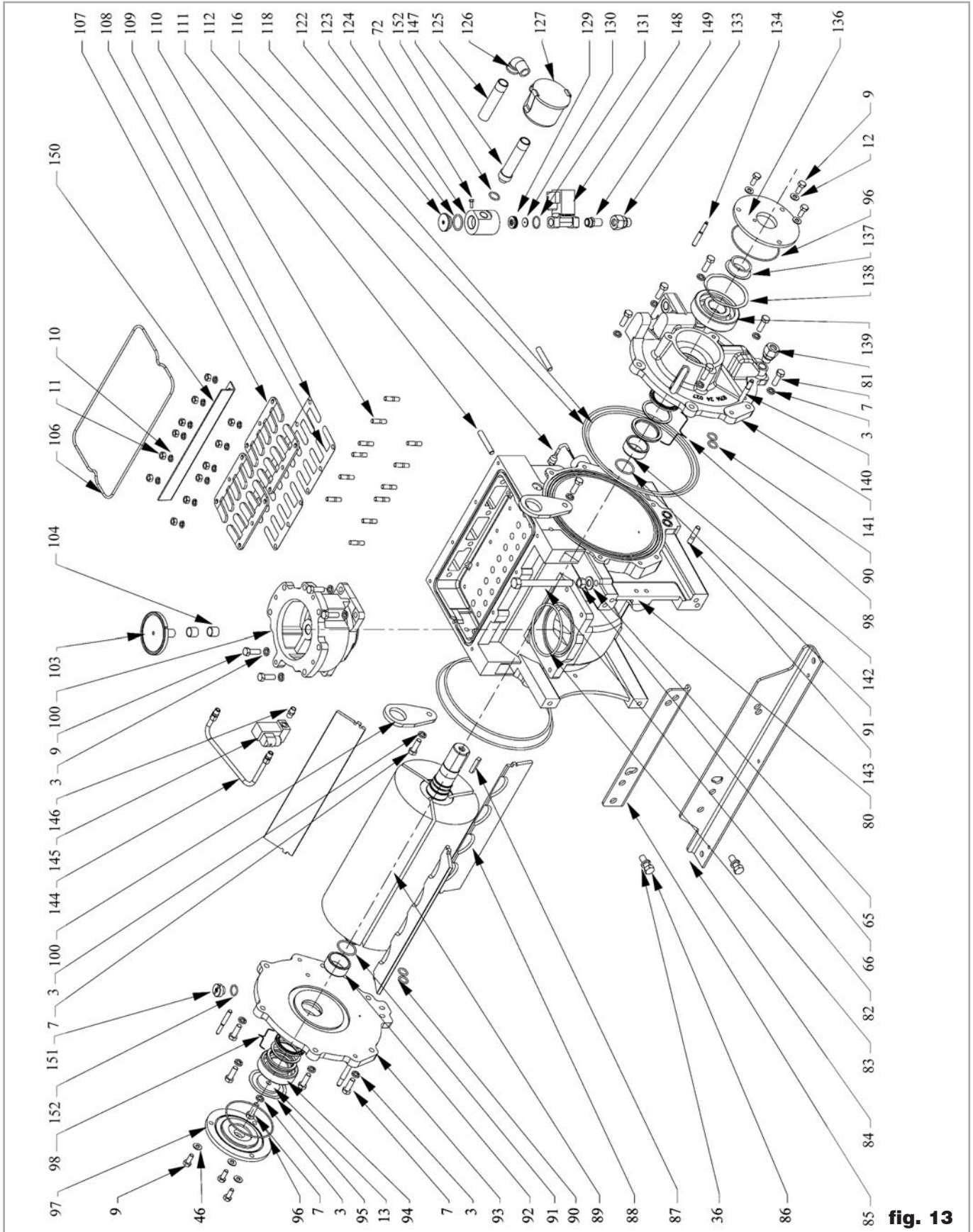

fig. 13

Spare parts

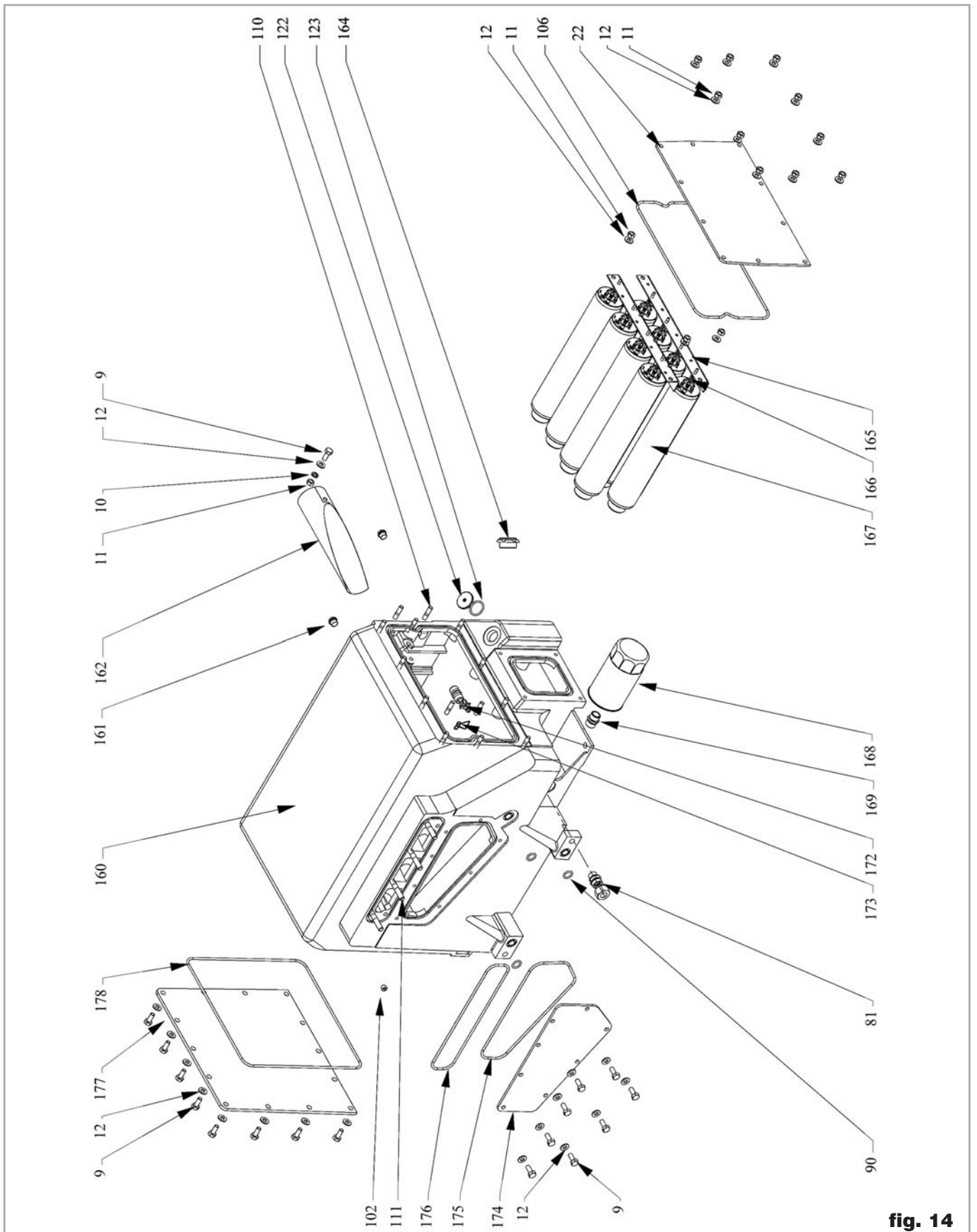

fig. 14

Spare parts

Pos.	Qty	Specification	Dimensions (mm)	Material	Ref. No.	Notes	9 714 37 310	960 863	960 867	9 714 37 320	9 714 37 330	9 714 37 340
1	1	OIL CASING			9 714 24 050							
2	10	NUT	HM12		V15 00 701							
3	15	WASHER	W12		V36 00 724							
4	1	O-RING	27 X 2.5	FKM	712 17 580		●	●		●		
5	1	PLUG	G 3/4		712 56 380			●				
6	1	BASE FRAME			9 714 30 740			●				
7	28	SCREW	HM12 X 35		V38 02 719					●		
8	3	WASHER	M12		V36 00 701							
9	30	SCREW	HM10 X 25		V38 02 615							
10	32	WASHER	W10		V36 00 624							
11	2	NUT	HM10		V15 00 601							
12	40	WASHER	MN10		V36 00 601							
13	1	COVER			9 714 25 750			●				
14	2	O-RING	158,12X5,33	FKM	712 37 460		●					
15	1	HOOD			9 714 32 390			●				
16	1	OIL TUBE			9 714 34 740			●				
17	1	OIL TUBE			9 714 34 730			●				
18	1	V-BELT (SET OF 4)			9 714 30 590	SV630 B / BF						
18	1	V-BELT (SET OF 4)			9 714 37 640	SV630 B US / JIS						
18	1	V-BELT (SET OF 4)			9 714 33 170	SV750 B						
19	2	DISC FOR ROTOR	D59XD12.5X6		712 49 660					●		
20	1	V-BELT PULLEY	DN250		9 714 31 890							
21	1	GENERATOR VACUUM GB			9 714 39 030						●	
22	3	COVER			9 714 25 270							
23	2	NUT MP	M12		V15 05 703							
24	1	UNIT STRETCHER			9 714 24 070							
25	12	SCREW	CHC M10 X 12		V38 11 606							
26	8	SCREW	CHC M10 X 25		V38 11 615							
27	1	OIL COOLER			9 714 32 800			●				
28	1	OIL COOLER BASE			9 714 25 110			●				
29	2	SCREW	HM8X16		V38 02 511			●				
30	2	WASHER	W8		V36 00 524			●				
31	1	FAN	D=350		9 714 31 620			●				
32	2	SCREW	CHC M8 X 40		V38 11 520							
33	1	ADAPTOR VENTILATOR			712 49 280	SV630 B EUR		●				
33	1	ADAPTOR VENTILATOR			712 49 570	SV630 B / BF US						
33	1	ADAPTOR VENTILATOR			712 49 560	SV750 B EUR						
33	1	ADAPTOR VENTILATOR			712 49 490	SV630 JIS						
34	1	PULLEY	DP140		714 15 750	SV630 B EUR/US/JIS		●				
34	1	PULLEY	DP170		9 714 33 160	SV750 B EUR						
35	1	HUB			714 03 930	SV630 B EUR		●				
35	1	HUB			714 03 940	SV630 B / BF US						
35	1	HUB			714 08 690	SV750 B EUR						
35	1	HUB			714 03 200	SV630 JIS						
36	4	WASHER	W14		V36 00 075							
37	4	NUT	HM14		V15 00 051							
38	1	MOTOR	15KW		714 05 010	SV630 B EUR		●				
38	1	MOTOR	25HP		712 39 570	SV630 B US						
38	1	MOTOR	18.5KW		714 05 200	SV750 B EUR						
38	1	MOTOR	18.5KW		712 51 610	SV630 B JIS						

Spare parts

Pos.	Qty	Specification	Dimensions (mm)	Material	Ref. No,	Notes	9 714 37 310	960 863	960 867	9 714 37 320	9 714 37 330	9 714 37 340
39	1	PIN	M14-55		9 714 34 010							
40	2	SCREW	HM14 X 55		V38 02 177							
41	2	WASHER	LL14N		V36 00 059							
42	1	INTAKE FLANGE 100ISOK EQ.	100ISOK		9 714 30 550			●				
43	1	COLLAR FLANGE	100PN10-100ISO-K		711 18 383			●				
44	10	RUBBER MOUNT	D=40 H=20		710 10 280							
45	1	PLATE			714 03 670							
46	1	HOOD (UPPER)UNIT			9 714 32 510							
47	1	PLUG	1-3/16		9 714 34 020							
48	1	HOOD			9 714 32 420							
49	1	HOOD UNIT			9 714 32 410							
50	1	NIPPLE			712 55 330				●			
51	1	VALVE	G3/4 DN20		712 35 740				●			
52	1	BASE FRAME			9 714 32 330				●			
53	1	PROTECTION			9 714 34 560				●			
54	1	COVER			9 714 33 490				●			
55	1	HOOD			9 714 32 400				●			
56	1	WATER TUBE			9 714 26 530				●			
57	1	WATER PLUG			712 49 700				●			
58	1	WATER TUBE			9 714 26 520				●			
59	1	OIL TUBE			9 714 34 770				●			
60	1	OIL TUBE			9 714 34 760				●			
61	1	THERMOSTATIC VALVE			712 32 450				●			
62	1	ELECTRICAL BOX			714 05 150				●			
63	1	HEAT EXCHANGER			9 714 26 690				●			
64	6	PIN	M16-80/50J=20		V21 00 472				●			
65	6	WASHER	M16		V36 00 801				●			
66	6	NUT	H M16		V15 00 801				●			
67	1	ROOTSADAPTER 2000			9 714 32 350				●			
68	1	O-RING	165X5	FKM	712 42 910		●		●			
69	1	EXHAUST FLANGE	100 ISO K		9 714 25 260				●			
70	1	O-RING	89X4	FKM	712 37 140		●		●			
71	2	PIN	M16-65/30J=24		V21 00 359				●			
72	16	SCREW	HM6X16		V38 02 411				●			
73	12	NUT	HM6		V15 07 400				●			
74	1	MOTOR	15KW		714 05 020	SV630 BF			●			
74	1	MOTOR	25HP		714 08 560	SV630 BF US						
75	1	O-RING	110 X 5	FKM	712 42 890		●					
80	1	MACHINED STATOR			9 714 24 000							
81	4	CONNECTION			714 05 810							
82	1	PUSH ROD			9 714 30 580							
83	1	O-RING	120,7X5,33	FKM	712 37 570		●					
84	1	MOTOR SUPPORT			9 714 24 980							
85	1	MOTOR SUPPORT			9 714 24 970							
86	2	SCREW	HM14 X 40		V38 00 071							
87	1	KEY			710 77 560							
88	1	SET OF VANE (3)			9 714 24 540					●		
89	1	ROTOR			9 714 24 480							
90	7	O-RING	18.64X3.53	FKM	9 714 24 600		●					
91	2	O-RING	44,04X3,53	FKM	712 37 420		●					

Spare parts

Pos.	Qty	Specification	Dimensions (mm)	Material	Ref. No.	Notes	9 714 37 310	960 863	960 867	9 714 37 320	9 714 37 330	9 714 37 340
92	1	RACE BUSHING	50X60X28		9 714 25 950					●		
93	1	FRONT END PLATE			9 714 24 010							
94	1	BALL BEARING 6309 C3	D100XD45X25		9 714 25 960					●		
95	1	SPRING RING 6309			9 714 25 970					●		
96	2	O-RING	123 X 3	FKM	712 37 100		●					
97	1	FRONT COVER			9 714 25 980							
98	2	SHAFT SEAL (SET)	DN60X80X7		714 03 120		●					
100	2	LIFTING LUG			9 714 32 640							
101	1	INLET FLANGE			9 714 23 990							
102	3	PLUG	R1/4		714 07 710							
103	1	ANTISUCKBACK VALVE			9 714 37 830		●					
104	2	RING			714 05 890							
105	1	SPRING			9 714 25 990			●		●		
106	2	O-RING	380,37X5,33	FKM	712 37 500		●					
107	4	VALVE STOP			9 714 25 920					●		
108	2	VALVE PLATE			9 714 25 900					●		
109	2	VALVE PLATE			9 714 25 910					●		
110	14	PIN	M10-25/15J=15		V21 00 526							
111	6	PIN	M12-50/35J=24		V21 13 645							
112	1	THERMALSWITCH			9 714 30 630			●				
112	1	THERMALSWITCH			9 714 40 000				●			
113	1	GAS BALLAST CONTROL ROD			9 714 26 080			●				
114	1	ELASTIC PIN			V22 00 112			●				
115	1	GBCONTROL GUIDE			9 714 26 090			●				
116	2	O-RING	304.17X5.33	FKM	9 714 24 620		●					
117	1	GAS BALLAST SPRING			714 17 990			●				
118	2	O-RING	278.77X5.33	FKM	9 714 24 610		●					
119	1	GASBALLAST VENTIL			9 714 26 060			●				
120	1	O-RING	10.77X2.62		712 37 320		●	●				
121	1	O-RING	4.42X2.62	FKM	9 714 24 460		●	●				
122	1	PLUG	G 1		710 73 040							
123	2	O-RING	33 X 3.5	FKM	712 17 410		●					●
124	1	GAS BALLAST FRAME			9 714 26 120			●				
124	1	GAS BALLAST FRAME			9 714 32 010				●			
125	1	GAS BALLAST TUBE	G3/4		9 714 32 560							
126	1	ELBOW	G3/4		710 78 760							
127	1	PAPER FILTER			710 38 200					●	●	
128	1	GAS BALLAST	R3/4		9 714 37 800			●				
129	1	GAS BALLAST SUPPORT			9 714 26 130							
130	1	GAS BALLAST MEMBRAN			9 714 26 150		●					
131	1	O-RING	25.07 X 2.62	FKM	9 714 30 800		●					
132	1	TUBE			9 714 33 950							
133	1	CONNECTION ELEMENT	G1/2 D18		714 03 890							
134	2	TAPERED PIN	10X45		9 714 30 520							
135	1	SCREW			9 714 24 710			●				
136	1	REAR COVER			9 714 25 940							
137	1	RACE BUSHING			9 714 25 930							
138	1	SPRING RING			714 03 190					●		
139	1	BALL BEARING	D120XD45X29		714 03 880					●		
140	2	TAPERED PIN			710 37 890							

Spare parts

Pos.	Qty	Specification	Dimensions (mm)	Material	Ref. No.	Notes	9 714 37 310	960 863	960 867	9 714 37 320	9 714 37 330	9 714 37 340
141	1	REAR END PLATE			9 714 24 020							
141	1	REAR END PLATE			9 714 24 420							
142	1	RACE BUSHING	D50X60X25		714 10 050				●			
143	1	PIN	M12-35/30J=18		V21 00 634							
144	1	OIL TUBE			9 714 33 480			●				
145	1	E.M. VALVE			714 05 860			●				
146	1	NIPPLE	R1/4		714 07 510			●				
147	1	REDUCER SEAL SOLDERED	3/4F - 1/2M		9 714 38 900			●				
148	1	EM VALVE.			714 05 870			●				
149	1	CONNECTION ELEMENT	DN18-1/2		9 714 30 990			●				
150	1	OIL HOLD BACK STEEL SHEET			9 714 37 760							
151	1	PLUG			712 31 810							
152	1	O-RING	22X3	FKM	712 17 670		●	●				
152	2	O-RING	22X3	FKM	712 17 670		●	●				
160	1	OIL CASING			9 714 24 040							
161	2	PLUG	G3/8		714 02 700							
162	1	EXHAUST DEFLECTOR			9 714 25 210							
164	1	OIL LEVEL GLASS			710 29 600				●			
165	2	DEMISTER SUPPORT UNIT			9 714 25 130							
166	8	SPRING			714 36 210							●
167	8	EXHAUST FILTER WITH BY PASS			9 714 31 120				●	●	●	
168	1	OIL FILTER			714 05 310				●	●	●	
169	1	NIPPLE	M24X1.5		710 35 730							
172	1	FLOAT COMPL.			714 17 210				●			
173	1	CLIP			9 714 25 870				●			
174	1	COVER			9 714 25 860							
175	1	O-RING	266,07X5,33	FKM	9 714 24 690		●					
176	1	O-RING	253,37X5,33	FKM	9 714 24 700		●					
177	1	COVER			9 714 25 710							
178	1	O-RING	456,06X5,33	FKM	712 37 560		●					
		SET OF SEALS			9 714 37 310		▲			●	●	
		SOGEVAC® AIR-COOLED	SV630 B / SV750 B		960 863			▲				
		SOGEVAC® WATER-COOLED	SV630 BF		960 867				▲			
		REPAIR KIT			9 714 37 320					▲		
		MODULE KIT			97 14 37 330						▲	
		SERVICE KIT			9 714 37340							▲

* For every order, please indicate the brand and the serial number of motor and of the pump.



EC Conformance Declaration

We, the Oerlikon Leybold Vacuum France, declare herewith that the products listed below, in the embodiment which we have placed on the market, comply with the applicable EC guidelines.

This declaration becomes invalid if modifications are made to the product without prior consultation with use. Maintaining the EMC guideline assumes an EMC compliant installation of the component within the plant or machine.

Product type: SOGEVAC

Model designation: SV16, SV25, SV40, SV65, SV10B, SV16B, SV16BI, SV28BI, SV40BI, SV25B, SV40B, SV65B, SV100B, SV100, SV200, SV300, SV500 SV630, SV750, SV1200, SV630B, SV750B
and their variants, excepted the pumps delivered without motor and the pumps delivered with EEx... motors

The products comply to the following guidelines :

- EC Directive on machines (98/37/EC)
- EC Low-Voltage Equipment Guidelines (73/23/EMG)+(98/68/EC)
- EC Directive on Electromagnetic Compatibility (89/336/EEC)

Related, harmonized standards:

- EN 1012, 1996
Compressors and vacuum pumps, safety requirements
Part 2: Vacuum pumps
- EN 60204-1, 1997
Safety of machinery - Electrical equipment of machines
Part 1: General requirements

Limits of use:

- The pump and its accessories are not designed for pumping aggressive, flammable, explosive gases or vapors or substances, phyrophoric gases or oxidizing agents.
- The pump and its accessories are not designed for working in aggressive, flammable, or explosive ambiance.
- For pumping oxygen in concentrations greater than atmospheric concentration (>20%) or other highly reactive gases, a special pump must be used. This pump must be modified and an inert oil (such as PFPE) must be used.

Contact Oerlikon Leybold Vacuum France for important safety precautions relative to these applications.

Other safety precautions and restrictions:

Refer to the manual delivered with the pumps. In any case, take adequate safety precautions.

Valence, January 12th 2007

Joseph Schott
Plant Manager

Valence, January 12th 2007

Jean-Luc Abraham
Vane pumps R&D Manager



Declaration of Contamination of Compressors, Vacuum Pumps and Components

The repair and / or servicing of compressors, vacuum pumps and components will be carried out only if a correctly completed declaration has been submitted. **Non-completion will result in delay.** The manufacturer can refuse to accept any equipment without a declaration.

A separate declaration has to be completed for each single component.

This declaration may be completed and signed only by authorised and qualified staff.

Customer/Dep./Institute: _____ Address: _____ Person to contact: _____ Phone: _____ Fax: _____ End user: _____	Reason for return <input checked="" type="checkbox"/> applicable please mark <input type="checkbox"/> Repair <input type="checkbox"/> chargeable <input type="checkbox"/> warranty <input type="checkbox"/> Exchange <input type="checkbox"/> chargeable <input type="checkbox"/> warranty <input type="checkbox"/> exchange already arranged / received Return only: <input type="checkbox"/> rent <input type="checkbox"/> loan <input type="checkbox"/> for credit Calibration: <input type="checkbox"/> DKD <input type="checkbox"/> Factory calibration <input type="checkbox"/> Quality test certificate DIN 55350-18-4.2.1
--	--

A. Description of the Leybold product Material description: _____ Catalog number: _____ Serial number: _____ Type of oil (Forevacuum pumps): _____	Failure description: _____ Additional parts: _____ Application Tool: _____ Application Process: _____
---	--

B. Condition of the equipment																																																		
1. Has the equipment been used ¹⁾ <input type="checkbox"/> 2. Drained (Product/service fluid) <input type="checkbox"/> 3. All openings sealed airtight <input type="checkbox"/> 4. Purged <input type="checkbox"/> If yes which cleaning agent: _____ and which method of cleaning: _____ 1) if answered with "No" go to D.	<table style="width: 100%; border-collapse: collapse;"> <thead> <tr> <th style="width: 10%;"></th> <th style="width: 10%; text-align: center;">No¹⁾</th> <th style="width: 10%; text-align: center;">Yes</th> <th style="width: 10%; text-align: center;">No</th> <th style="width: 30%;"></th> <th style="width: 10%; text-align: center;">No¹⁾</th> <th style="width: 10%; text-align: center;">Yes</th> </tr> </thead> <tbody> <tr> <td></td> <td style="text-align: center;"><input type="checkbox"/></td> <td style="text-align: center;"><input type="checkbox"/></td> <td style="text-align: center;"><input type="checkbox"/></td> <td style="text-align: center;">→</td> <td style="text-align: center;"><input type="checkbox"/></td> <td style="text-align: center;"><input type="checkbox"/></td> </tr> <tr> <td></td> <td style="text-align: center;"><input type="checkbox"/></td> <td style="text-align: center;"><input type="checkbox"/></td> <td style="text-align: center;"><input type="checkbox"/></td> <td></td> <td style="text-align: center;"><input type="checkbox"/></td> <td style="text-align: center;"><input type="checkbox"/></td> </tr> <tr> <td></td> <td style="text-align: center;"><input type="checkbox"/></td> <td style="text-align: center;"><input type="checkbox"/></td> <td style="text-align: center;"><input type="checkbox"/></td> <td></td> <td style="text-align: center;"><input type="checkbox"/></td> <td style="text-align: center;"><input type="checkbox"/></td> </tr> <tr> <td></td> <td style="text-align: center;"><input type="checkbox"/></td> <td style="text-align: center;"><input type="checkbox"/></td> <td style="text-align: center;"><input type="checkbox"/></td> <td></td> <td style="text-align: center;"><input type="checkbox"/></td> <td style="text-align: center;"><input type="checkbox"/></td> </tr> <tr> <td></td> <td style="text-align: center;"><input type="checkbox"/></td> <td style="text-align: center;"><input type="checkbox"/></td> <td style="text-align: center;"><input type="checkbox"/></td> <td></td> <td style="text-align: center;"><input type="checkbox"/></td> <td style="text-align: center;"><input type="checkbox"/></td> </tr> <tr> <td></td> <td style="text-align: center;"><input type="checkbox"/></td> <td style="text-align: center;"><input type="checkbox"/></td> <td style="text-align: center;"><input type="checkbox"/></td> <td></td> <td style="text-align: center;"><input type="checkbox"/></td> <td style="text-align: center;"><input type="checkbox"/></td> </tr> </tbody> </table>		No ¹⁾	Yes	No		No ¹⁾	Yes		<input type="checkbox"/>	<input type="checkbox"/>	<input type="checkbox"/>	→	<input type="checkbox"/>	<input type="checkbox"/>		<input type="checkbox"/>	<input type="checkbox"/>	<input type="checkbox"/>		<input type="checkbox"/>	<input type="checkbox"/>		<input type="checkbox"/>	<input type="checkbox"/>	<input type="checkbox"/>		<input type="checkbox"/>	<input type="checkbox"/>		<input type="checkbox"/>	<input type="checkbox"/>	<input type="checkbox"/>		<input type="checkbox"/>	<input type="checkbox"/>		<input type="checkbox"/>	<input type="checkbox"/>	<input type="checkbox"/>		<input type="checkbox"/>	<input type="checkbox"/>		<input type="checkbox"/>	<input type="checkbox"/>	<input type="checkbox"/>		<input type="checkbox"/>	<input type="checkbox"/>
	No ¹⁾	Yes	No		No ¹⁾	Yes																																												
	<input type="checkbox"/>	<input type="checkbox"/>	<input type="checkbox"/>	→	<input type="checkbox"/>	<input type="checkbox"/>																																												
	<input type="checkbox"/>	<input type="checkbox"/>	<input type="checkbox"/>		<input type="checkbox"/>	<input type="checkbox"/>																																												
	<input type="checkbox"/>	<input type="checkbox"/>	<input type="checkbox"/>		<input type="checkbox"/>	<input type="checkbox"/>																																												
	<input type="checkbox"/>	<input type="checkbox"/>	<input type="checkbox"/>		<input type="checkbox"/>	<input type="checkbox"/>																																												
	<input type="checkbox"/>	<input type="checkbox"/>	<input type="checkbox"/>		<input type="checkbox"/>	<input type="checkbox"/>																																												
	<input type="checkbox"/>	<input type="checkbox"/>	<input type="checkbox"/>		<input type="checkbox"/>	<input type="checkbox"/>																																												

C. Description of processed substances (Please fill in absolutely)	
1. What substances have come into contact with the equipment: Trade name and / or chemical term of service fluids and substances processed, properties of the substances; According to safety data sheet (e.g. toxic, inflammable, corrosive, radioactive)	
Tradename: _____ a) _____ b) _____ c) _____ d) _____	Chemical name: _____ 2. Are these substances harmful? <input type="checkbox"/> No <input type="checkbox"/> Yes 3. Dangerous decomposition products when heated? <input type="checkbox"/> No <input type="checkbox"/> Yes If yes, which? _____

²⁾ Components contaminated by microbiological, explosive or radioactive products/substances will not be accepted without written evidence of decontamination.

D. Legally binding declaration

I / we hereby declare that the information supplied on this form is accurate and sufficient to judge any contamination level.

Name of authorised person (block letters): _____ Date _____ Signatur of authorised person _____	<div style="border: 1px dashed black; width: 100%; height: 100%;"></div> firm stamp
--	---