

Chemtech Scientific provides access to this content as a courtesy.
We do not own the content contained in this document.
All rights and credit go directly to its rightful owners.
www.chemtechsci.com
Call us at: 484-424-9415

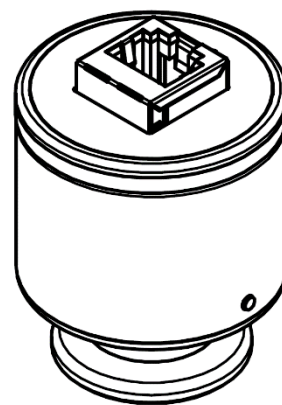

THERMOVAC Transmitter

TTR 91 N, TTR 91 N S, TTR 96 N S and TTR 96 N SC

Operating Manual 300544652_002_C1

Part Numbers:

230035V02
230036V02
230037V02
230038V02
230040V02
230043V02
230045V02
230047V02

Contents

0	Safety Information	3
0.1	Symbols used	3
0.2	Personnel Qualifications	3
0.3	General safety information	3
0.4	Liability and Warranty	5
1	Unpacking	6
2	Description	7
2.1	Technical Data	8
2.2	Dimensions	9
2.3	Accessories and replacement part numbers	10
3	Transmitter Installation (Mechanical)	11
3.1	Conforming utilization	11
3.2	Non-conforming utilization	11
3.3	Process compatibility	11
3.4	Vacuum connections	12
3.5	Pressure range	12
4	Transmitter Installation (Electrical)	13
4.1	Input/Output Wiring	14
4.2	Setpoint relays	15
5	Operations	16
5.1	Pressure output	16
5.2	Analog output	17
5.3	Sensor gas dependence	18
6	Functions	19
6.1	LED-ring/LED status indicator	19
6.2	Vacuum-zero/full-scale adjustment and setpoint adjustment	20
6.3	User switch adjustments	21
7	FAQ (Frequently Asked Questions)	25
8	Trouble shooting	27
9	Declaration of Contamination	28
10	Declaration of Conformity	30
11	Notes	31
12	Sales and Service	32

0 Safety Information

0.1 Symbols used

The first two symbols identify other information in this manual that is essential or useful in achieving optimal performance from the transmitter. The last symbol below is used throughout this manual to further define the safety concerns associated with the product.



Critical

Failure to read message could result in damage to the equipment.



Attention

Calls attention to important procedures, practices or conditions.



Caution

Refer to manual. Failure to read message could result in personal injury or serious damage to the equipment or both.

0.2 Personnel Qualifications



Skilled personnel

All work described in this document may only be carried out by persons who have suitable technical training and the necessary experience or who have been instructed by the end-user of the product.

0.3 General safety information

The safety instructions should always be followed during installation and operation of the transmitter. Pass safety information to all users.

- Adhere to the applicable regulations and take the necessary precautions for the process media used. Consider possible reactions between the materials and the process media. Consider possible reactions (e.g. explosion) of the process media due to the heat generated by the product.
- Adhere to the applicable regulations and take the necessary precautions for all work you are going to do and consider the safety instructions in this document.
- Before beginning to work, find out whether any vacuum components are contaminated. Adhere to the relevant regulations and take the necessary precautions when handling contaminated parts.

Safety Precautions:



Critical



Explosive Environments. Do not use the transmitter in presence of flammable gases or other explosive environments.

Corrosive Environments. The transmitter is not intended for use in corrosive environments. Refer to Transmitter installation chapter 3 of this manual. If you need further support please contact Leybold.

 **Critical**



Service and Repair. Do not substitute parts or modify instrument. Do not install substituted parts or perform any unauthorized modification to the instrument. Return the instrument to an Leybold Calibration and Service Center for service and repair to ensure all of the safety features are maintained.

 **Critical**



DANGER: contaminated parts

Contaminated parts can be detrimental to health and environment. Before beginning to work, find out whether any parts are contaminated. Adhere to the relevant regulations and take the necessary precautions when handling contaminated parts.

 **Critical**



DANGER: Overpressure in the vacuum system

KF flange connections with elastomer seals (e.g. O-rings) cannot withstand pressures <2,5bar. Process media can thus leak and possibly damage your health.

 **Attention**



Caution: vacuum component

Dirt and damages impair the function of the vacuum component. When handling vacuum components, take appropriate measures to ensure cleanliness and prevent damages.

 **Attention**



CE marking The transmitter complies with European standards for CE marking. Refer to Declaration of Conformity chapter 10 of this manual.

 **Caution**



Fuse. The transmitter power supply input has an internal thermal fuse. The fuse is self-recoverable and should not be changed.

 **Caution**



Electrical connections. The transmitter must be properly electrically connected in order to perform according to the specifications.

Output pins are not protected against wrong electrical connections. Wrong electrical connections can cause permanent damage to the transmitter or interference to measuring performance. Refer to electrical connections description in chapter 4 of this manual.

 **Caution**



Caution: dirt sensitive area

Touching the product or parts thereof with one's bare hands increases the desorption rate. Always wear clean, lint-free gloves and use clean tools when working in this area.

0.4 Liability and Warranty

Leybold assumes no liability and the warranty becomes null and void if the end-user or third parties

- disregard the information in this document
- use the product in a non-conforming manner
- make any kind of interventions (modifications, alterations etc.) on the product
- use the product with accessories not listed in the product documentation

The end-user assumes the responsibility in conjunction with the process media used. Transmitter failures due to contamination are not covered by the warranty.

1 Unpacking

Before unpacking your transmitter, check all surfaces of the packing material for shipping damage. Inspect for visible damage. If found, notify the carrier immediately.

Please be sure that your transmitter package contains these items:

- 1 pcs. TTR 91 N or TTR 96 N THERMOVAC Transmitter
- 1 pcs. English short form manual (P/N: 300544666_002)
- 1 pcs. German short form manual (P/N: 300544666_001)
- 1 pcs. Product Inspection and Test Report
- 1 pcs. Pin for adjusting settings via button

If any items are missing, please contact Leybold.

2 Description

The TTR 91 N and TTR 96 N THERMOVAC series vacuum transmitters offer a wide measuring range from 5×10^{-5} to 1000 mbar and are based on the measurement of thermal conductivity in a small cavity on a MEMS Pirani silicon chip sensor.

The TTR 91 N and TTR 96 N THERMOVAC transmitters can be used in a variety of applications as standalone units or with Graphix controllers (P/N: 230680V01, 230681V01, 230682V01) and the Display controllers (P/N: 230001, 230024, 230025). All THERMOVAC transmitters are backward compatible with Graphix, Display and Center controllers.

Each transmitter is individually tested throughout the measuring range before leaving the factory. A test report is included in the package. In addition, each transmitter pressure reading is individually temperature-compensated within the specified operating temperature range.

The transmitters have up to three mechanical relays which can be used for process control, for example interlocking valves or pumps. The analog voltage output can be interfaced to external analog equipment for pressure readout or controlling.

Sensor technology

The transmitters have a single MEMS Pirani (MEMS = Micro-Electro-Mechanical-System) sensor element whose measurements are based on measurement of thermal conductivity. The MEMS Pirani sensor consists of a silicon chip with a heated resistive element forming one surface of a cavity. A cover on top of the chip forms the other surface of the cavity. Due to the geometry of the sensor, convection cannot take place within the cavity and consequently the sensor is insensitive to mounting position. Gas molecules are passed by diffusion only to the heated element where the heat loss of the gas is measured. The sensor element is very robust and can withstand high G-forces and instant air inrush.

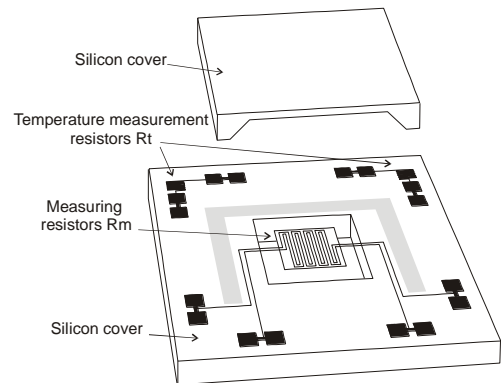

Applications

The transmitters can be used in many different vacuum applications within e.g. the industrial application, research and development, semiconductor, analytical and coating industries:

- General vacuum pressure measurement
- Fore line and roughing pressure measurement
- Gas backfilling measurement and controlling
- Mass spectrometer control
- Activation of UHV gauge
- System process control
- Sense abnormal pressure and take appropriate security measure using relay set points
- Control system pressure

P/N: 230045V02 and 230047V02 contain Parylene-HT® coated sensors.

Parylene-HT® is a conformal coating with excellent gas barrier properties with no outgassing. Sensors coated with Parylene-HT® offer better resistance against various corrosive gases compared to the standard MEMS Pirani. The coating covers the entire sensor chip, including wiring. Hence the only material exposed to the process gas is the Parylene-HT® coating. Please contact Application support for further information.

Disposal

The TTR 91 N and 96 N transmitters are manufactured according to the RoHS directive.



Attention

For the benefit of the environment, at the end of life of the transmitter, it should not be disposed in the normal unsorted waste stream. It should be deposited at an appropriate collection point or facility to enable recovery or recycling.

Parylene-HT® is a trademark of Specialty Coating Systems, Inc

2.1 Technical Data

Measurement principle:	Thermal conductivity according to a MEMS Pirani sensor	
Measurement range (N ₂ and Air):	5×10 ⁻⁵ to 1000 mbar	
Accuracy ⁽¹⁾ (N ₂):	5×10 ⁻⁴ to 1×10 ⁻³ mbar:	±10% of reading
	1×10 ⁻³ to 100 mbar:	± 5% of reading
	100 to 1000 mbar:	± 25% of reading
Repeatability ⁽¹⁾ (N ₂):	1×10 ⁻³ to 100 mbar:	± 2% of reading
Supply Voltage:	9 – 30 VDC	
Power consumption:	< 1.2 Watt	
Fuse (thermal recoverable):	200 mA	
Analog output (100 Ω impedance):	0.61 – 10 VDC, Log. 1.286 VDC/decade	
Analog output resolution:	16 bit	
Analog output update rate:	16 Hz	
Sensor fail, analog output:	0.5 V	
Materials exposed to vacuum ⁽²⁾ :		
P/N: 230035V02 to 230043V02:	304 stainless steel, sealing material FPM	
P/N: 230045V02, 230047V02:	304 stainless steel, sealing material FPM, Parylene-HT®	
Setpoint relay(s):		
P/N: 230035V02 to 230038V02:	0	
P/N: 230040V02 to 230047V02:	2	
Setpoint relay range:	2×10 ⁻⁴ to 1000 mbar	
Setpoint relay contact rating:	1A / 30 VDC/AC (resistive load)	
Setpoint relay response time:	< 100 ms	
Setpoint relay contact resistance:	100 mΩ (max)	
Setpoint relay contact endurance:	100,000 cycles (min) (30 VDC/1 A load)	
Setpoint relay contact endurance:	2,000,000 cycles (min) (30 VDC/0.2 A load)	
Internal volume:		
P/N: 230035V02, 230040V02, 230045V02:	KF16	2.80 cm ³
P/N: 230036V02:	CF 16	3.71 cm ³
P/N: 230038V02, 230043V02:	NPT 1/8"	3.04 cm ³
P/N: 230037V02, 230047V02:	CF 16 (bakeable)	23.14 cm ³
Housing material:	Stainless steel 304	
Weight:		
P/N: 230035V02, 230040V02, 230045V02:	168 g	
P/N: 230036V02:	195 g	
P/N: 230038V02, 230043V02:	183 g	
P/N: 230037V02, 230047V02:	250 g	
Maximum allowed pressure:	6 bar	
Operating temperature:	0 to 40 °C (32 to 104 °F)	
Bakeout temperature (Power off) ⁽³⁾ :	85 °C (185 °F)	
	250 °C (482 °F) (only for P/N: 230037V02, 230047V02) ⁽³⁾	
Filament temperature:	35 °C above ambient temperature	
Ingress Protection Rating:	IP40	
Leak rate	< 5·10 ⁻⁹ mbar·l/s	

(1) Accuracy and repeatability values are typical values measured in Nitrogen atmosphere at ambient temperature after zero adjustment.

(2) For the full list of all materials exposed to process gases please contact Leybold.

(3) This bakeout temperature is only allowed at the end of the CF 16 flange. The temperature of the transmitter must not exceed 85 °C (185 °F). Thus, it is not recommended to thermally insulate or directly heat the transmitter and flange during bakeout.

2.2 Dimensions

[mm]

P/N: 230035V02 to 230047V02

Flanges:
KF 16

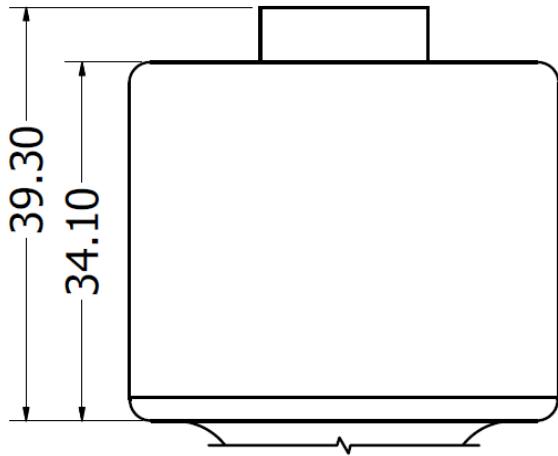
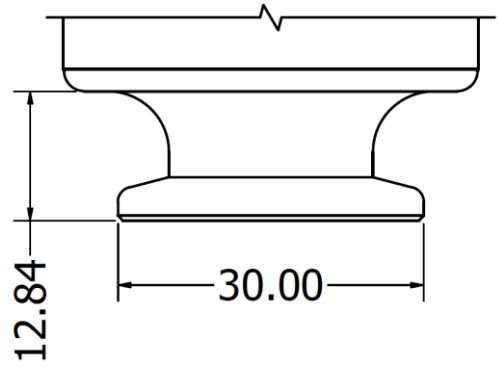
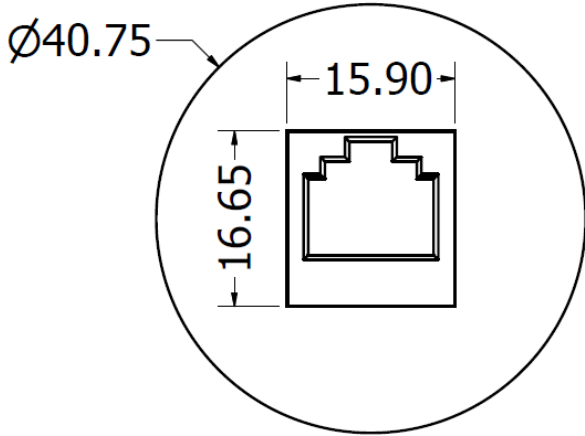

CF 16

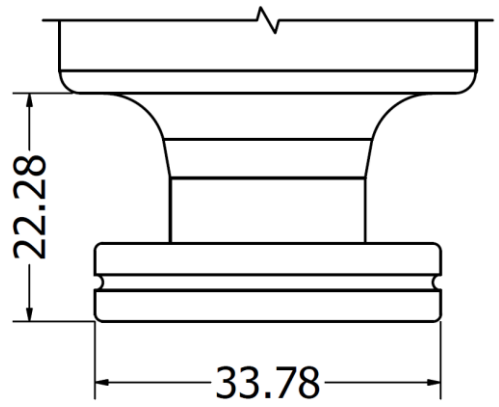

CF 16 (bakeable)

NPT 1/8"

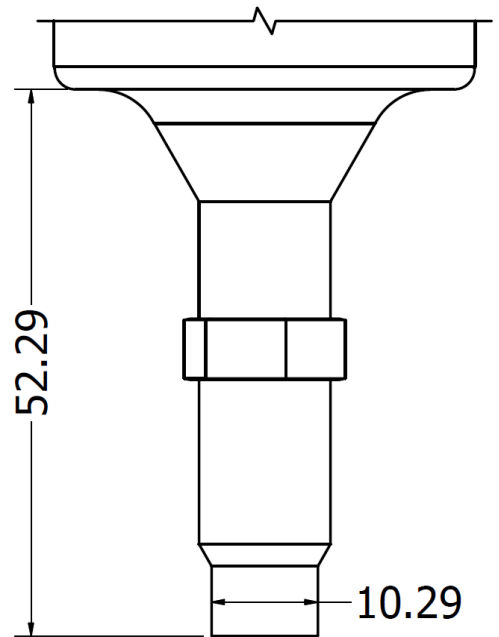
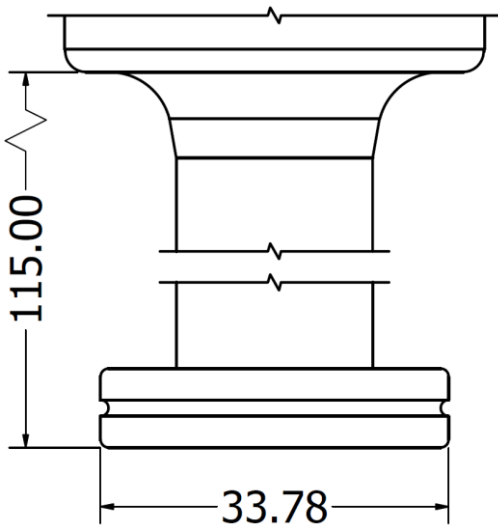

2.3 Accessories and replacement part numbers

Part	Part no.
TTR 91 N, DN16 KF	230035V02
TTR 91 N, DN16 CF	230036V02
TTR 91 N, DN16 CF, bakeable	230037V02
TTR 91 N, 1/8" NPT	230038V02
TTR 91 N, DN16 KF, 2SP	230040V02
TTR 91 N, 1/8" NPT, 2SP	230043V02
TTR 96 N C, DN16 KF, 2SP	230045V02
TTR 96 N C, DN16 CF, bakeable, 2SP	230047V02
Display One	230001
Display Two	230024
Display Three	230025
Graphix One	230680V01
Graphix Two	230681V01
Graphix Three	230682V01
Cables Type A 5 Meter	12426
Cables Type A 10 Meter	230012
Cables Type A 15 Meter	12427
Cables Type A 20 Meter	12428
Cables Type A 30 Meter	12429
Cables Type A 50 Meter	12431
Cables Type A 75 Meter	12432
Cables Type A 100 Meter	12433
Spiral tube DN 16 ISO-KF	230082
Centering Rings (Stainless Steel 1.4305) with O-Ring, DN16 KF	88346
Centering Rings (Stainless Steel) with Sintered Metal Filter, DN16 KF	88351
Clamping Rings (Aluminium), DN16 KF	18341
Centering Ring with fine filter DN 16 ISO-KF	88396
CF Bolts with double nut M4+20	83887
CF Copper gaskets DN16 CF	ES83941

3 Transmitter Installation (Mechanical)

3.1 Conforming utilization

- The transmitter is intended for measuring pressure.
- The transmitters are intended for use in relatively clean environments.
- The transmitter can only be used by persons who have suitable technical training and the necessary experience or who have been instructed by the end-user of the product.
- Always ensure that all vacuum sealing items and surfaces are clean, without damage and free of particles.
- Use a cable with strain relief to ensure proper electrical connection and to reduce stress on the connectors.
- To comply with EN61326-1 immunity requirements, use a braided, shielded cable.

3.2 Non-conforming utilization

- The transmitter cannot be used for measurements other than described in this manual.
- The transmitters are not intended for use in dirty and corrosive environments
- Do not use the transmitter in presence of flammable gases or other explosive environments.
- Do not install substituted parts or perform any unauthorized modification to the instrument.
- The transmitter is not intended for use above maximum allowed pressure.

3.3 Process compatibility

The TTR 91 N and TTR 96 N transmitters are intended for use in relatively clean environments. The transmitters cannot be used in corrosive environments like a semiconductor etch process chamber where aggressive gases like fluorine are used. The Parylene-HT® coated sensors (P/N: 230045V02, 230047V02) offer improved corrosion resistance. The Parylene-HT® coating can be compromised when exposed to aggressive environments for long periods or in high concentration corrosive environments. Furthermore, environments used for stripping Parylene-HT®, like a reactive oxygen plasma, will also damage the sensor over time.

If the transmitter is located close to a gas source connection like a flow controller or leak valve, the transmitter pressure measurement can be higher than the actual chamber pressure. Location close to a pumping system connection can cause a lower pressure measurement than actual chamber pressure.

The transmitters and their sensor design can be mounted in any orientation without compromising accuracy. However it is not recommended to mount the transmitters upside down, as dust and dirt might fall into the sensor.

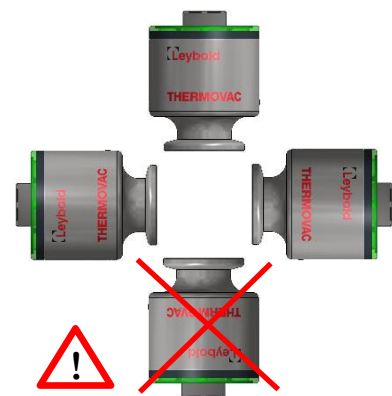

Not recommended



Caution

Do not use or install the transmitter where the following conditions occur:

- Temperatures lower than 0 °C or higher than 40 °C
- Corrosive or explosive gases
- Direct sunlight or other heat sources



Explosive Environments

The sensor filament is kept at a low temperature of only 35 °C above ambient temperature, however in case of malfunction in the sensor element can exceed normal operating temperature and consequently the transmitter should not be used in explosive environments.

Temperature

The transmitters have an active and individual sensor temperature compensation circuit that ensures accurate measurement in a wide temperature range.

For best measuring performance avoid large temperature gradients and direct cooling like air-condition air stream or heating like a pump exhaust stream.

Bake out

The transmitter electronics can withstand maximum 85 °C (185 °F) when the power is turned off.

The bakeout temperature of 250 °C (482 °F) (for P/N: 230037V02, 230047V02) is only allowed at the end of the CF 16 flange. The temperature of the transmitter must not exceed 85 °C (185 °F). Thus, it is not recommended to thermally insulate or directly heat the transmitter and flange during bakeout.

Contamination

Locate and orient the transmitter where contamination is least likely. The sensor has a low filament temperature of only 35 °C above ambient temperature; therefore, the sensor is less prone to contamination by cracking products from fore vacuum pump oil.



Attention

If the transmitter is backfilled with a liquid like pump oil the sensor element is likely permanently damaged. The transmitter cannot be cleaned using solvents.

Vibrations and instant air inrush

The sensor element is extremely robust to mechanical forces like vibration and G-forces. The sensor element cannot be damaged by fast and repeated pressure cycles or instant inrush of air.

3.4 Vacuum connections

The transmitters are available with different types of vacuum fittings. When mounting the transmitter, always ensure that all vacuum sealing items and surfaces are clean, without damage and free of particles. Do not touch the vacuum flange sealing surface.



Caution

If the transmitter will be exposed to pressures above atmospheric pressure make sure that proper vacuum fittings are used. Ensure that the internal system pressure is at ambient pressure conditions before opening the vacuum system and removing any connections.

3.5 Pressure range

The standard TTR 91 N and TTR 96 N THERMOVAC Transmitters are internally sealed with elastomer FPM sealing and are intended for use in the pressure range 5×10^{-5} to 1000 mbar. If used in UHV applications the outgassing rate of FPM can be too high.

4 Transmitter Installation (Electrical)

Use a cable with strain relief to ensure proper electrical connection and to reduce stress on the connectors.



Attention



Ensure a low impedance electrical connection between the transmitter body and the grounded vacuum system to shield the sensor from external electromagnetic sources.
Ensure that the analog output is connected to floating input.

To comply with EN61326-1 immunity requirements, use a braided, shielded cable. Connect the braid to the metal hoods at both ends of the cable with the end for power supply connected to earth ground.

Ground loops, differences of potential, or EMC problems may affect the measurement signal. For optimum signal quality, please do observe the following notes:

- Use an overall metal braided shielded cable. The connector must have a metal case.
- Connect the cable shield to ground at one side via the connector case. Make sure the connector case has direct contact to the cable's shield on its whole circumference. Do not connect the other side of the shield.
- Connect the supply common with protective ground directly at the power.
- Use differential measurement input (signal common and supply common conducted separately).
- Potential difference between supply common and housing ≤ 18 V (overvoltage protection).

The power supply input is 9 to 30 VDC. The power supply input is protected by an internal thermal fuse. The fuse is self-recoverable; do not replace it. Damage may occur to the circuitry if excessive voltage is applied, polarity reversed, or if a wrong connection is made.

If using the analog voltage output, connect the positive analog out and negative analog out pins to a differential input voltmeter or an analog-to-digital (A/D) converter. Do not connect the negative side of the analog output to the negative side of the power supply input or to any other ground. Doing so will cause half of the power current to flow through this wire. Measurement errors in the output voltage may be seen due to the voltage drop from this current. The longer the cable, the worse the error will be. Do not connect the set point relay terminals to the analog output.

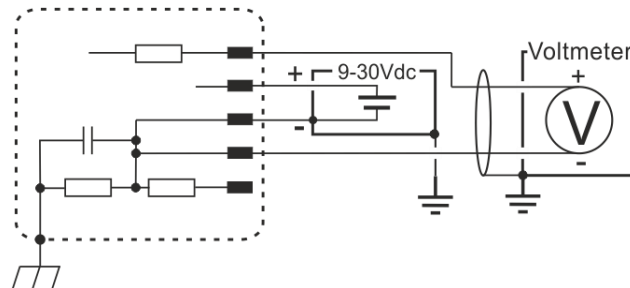

Correct connection of analog output to floating input

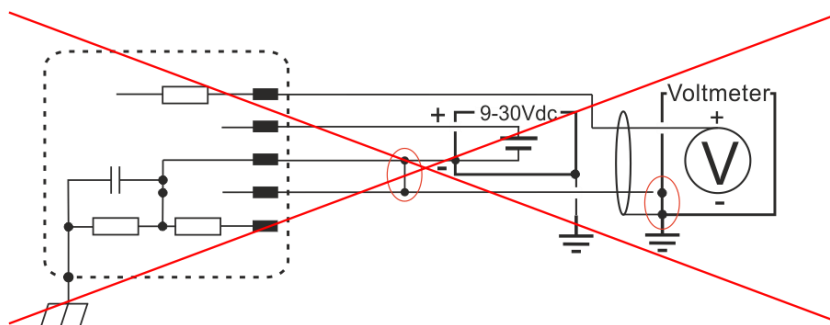

Incorrect connection of analog output to non-floating input

4.1 Input/Output Wiring

To comply with EN61326-1 immunity requirements, use a braided, shielded cable. Connect the braid to the metal hoods at both ends of the cable with the end for power supply connected to earth ground.

Part Numbers: 230035V02 to 230038V02:

I/O Connector (8 pin RJ45/FCC68)

PIN Description

1	Power + (9-30 VDC)	5	Analog Output -
2	Power return - (GND)	6	Not Connected
3	Analog Output +	7	Not Connected
4	ID-Resistor, 27 k Ω ($\pm 1\%$)	8	Not Connected

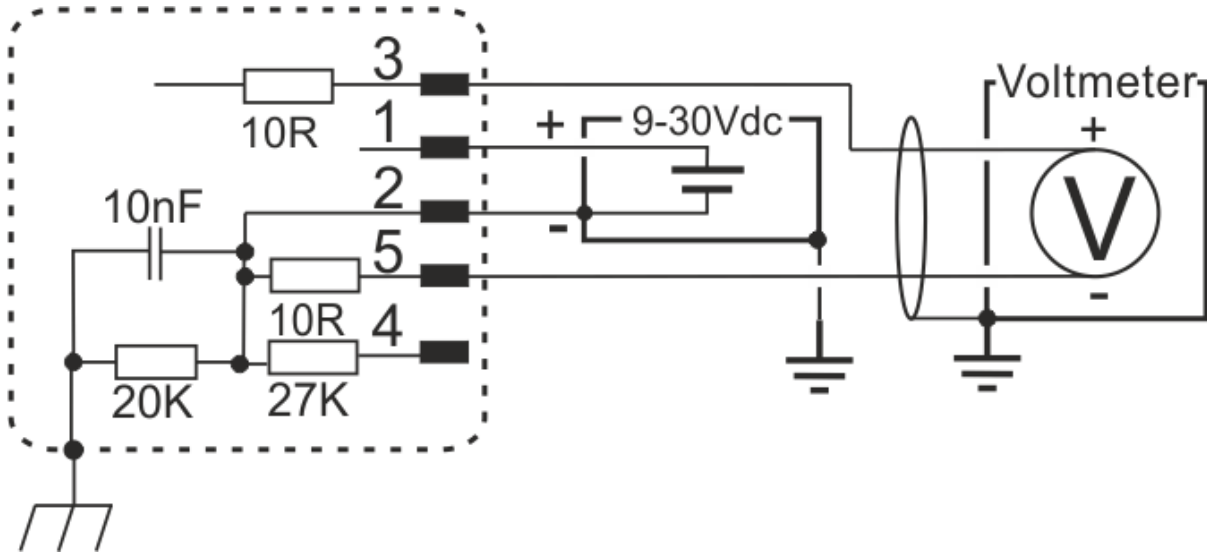
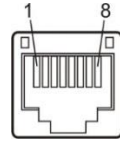

Part Numbers: 230040V02 to 230047V02:

I/O Connector (8 pin RJ45/FCC68)

PIN Description

1	Power + (9-30 VDC)	5	Analog Output -
2	Power return - (GND)	6	Relay Setpoint 2 (closing contact)
3	Analog Output +	7	Relay Setpoint 1 (closing contact)
4	ID-Resistor, 27 k Ω ($\pm 1\%$)	8	Relay Setpoint 1 and 2 Common

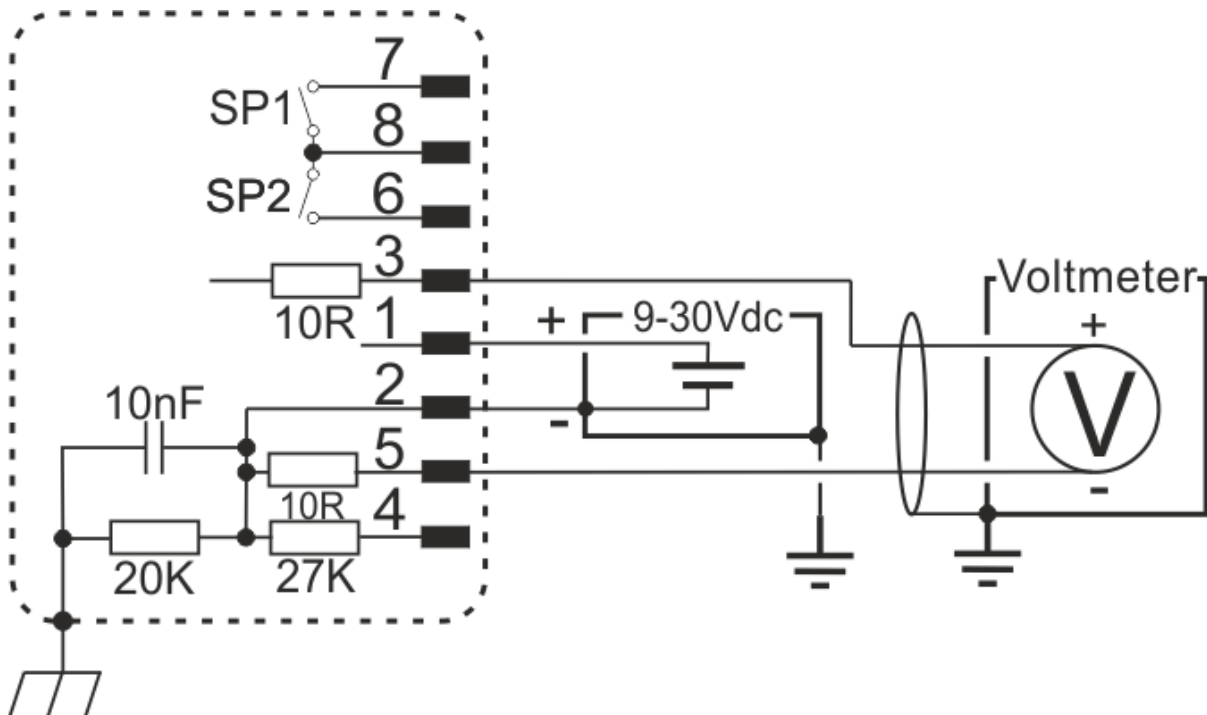
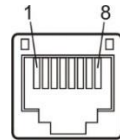

4.2 Setpoint relays

The TTR 91 N and TTR 96 N THERMOVAC transmitters have up to three mechanical relays that can be used for controlling external process equipment. The relay has closing and breaking contacts and the contacts are rated 30 VDC, 1 A, resistive load. For further information about the setpoint adjustment, refer to chapter 6.

Inductive relay load

Special precautions should be taken when driving inductive loads with the relay contact. When an inductive load like a solenoid is energized, the in-rush current is significant higher than the regular load current. In-rush currents exceeding the relay contact rating can cause reduction of relay contact life time or contact reliability.

When a solenoid is de-energized, the collapsing magnetic field can cause significant voltage spikes. These spikes can couple capacitively from cable to cable and interfere with measuring electronics or transmitter signal.

Critical



Driving inductive loads via the setpoint relay contacts requires de-energizing spike protection. Inadequate protection can cause permanent damage to the transmitter or interfere with the analog output signal.

Always ensure that inductive in-rush currents do not exceed relay contact rating.

An arc suppression network, as shown schematically to the right, is recommended. The values of the capacitance C and the resistance R can be calculated by the following equations:

$$C = I^2 / (1 \times 10^7) \quad R = E / I^a$$

where:

C is in Farads. R is in ohms

I is DC or AC_{peak} load current in amperes. E is DC or AC_{peak} source voltage in volts

$$a = 1 + (50 / E)$$

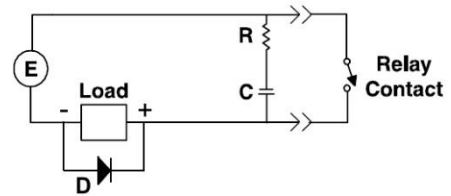

Note that $R_{min} = 0.5 \Omega$ and $C_{min} = 1 \times 10^{-9} F$, D is a fast transient suppression diode.

Setpoint functionality

The set point relays can be activated either above or below the set point values. The graphs below show the different relays stages in either below or above configuration. The NC contact will always be closed in case of power failure.

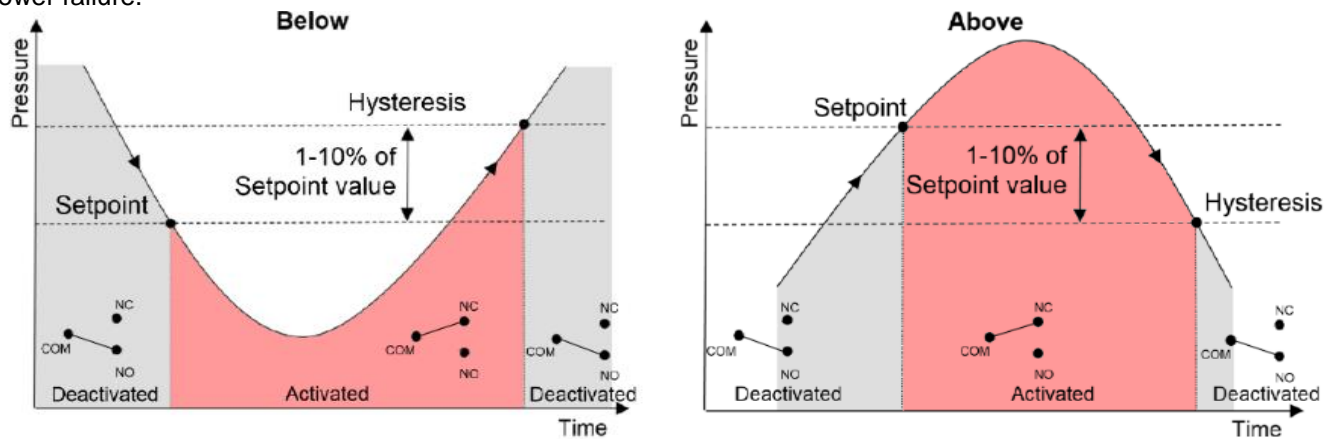

Critical



When using the setpoint relay to control process equipment always take appropriate precautions to prevent system damage in case of transmitter power failure. The NC contact will be closed in case of transmitter power failure.

To adjust the set point relays to above or below switching functionality you must follow the procedure like described in chapter 6.3.

It is important to understand that when the signal is declining during adjustment you will set the below function and if the signal is increasing you will set the above function.

To change the direction of signal adjustment, you must keep the button pressed until reaching top or low end of the set point range, then the signal will change its direction.

5 Operations

5.1 Pressure output

The TTR 91 N and TTR 96 N THERMOVAC transmitters can provide pressure measurement output as an analog voltage value.

The analog output provides a 16 bit resolution. Refer to chapter 5.2 for further details.



Caution



When designing external pressure control loops make sure that external equipment, like a pumping system, is not damaged if the transmitter output enters Sensor defect mode or in case of power failure.



Caution



When designing pressure data collecting software and controlling loop make sure that the software does not interpret a communication error as a valid pressure value.

Measuring noise

External sources can interfere with the sensor signal and cause noise on the signal. The low measuring range is most sensitive to measuring noise due to low signal levels.

5.2 Analog output

The TTR 91 N and TTR 96 N THERMOVAC transmitters provide a voltage output a function of pressure. The output is 1.286 VDC/decade.

Conversion formulae:

$$P_{\text{mbar}} = 10^{((V_{\text{out}} - 6.143)/1.286)}$$

$$V_{\text{out}} = \log_{10}(P_{\text{mbar}}) \times 1.286 + 6.143$$

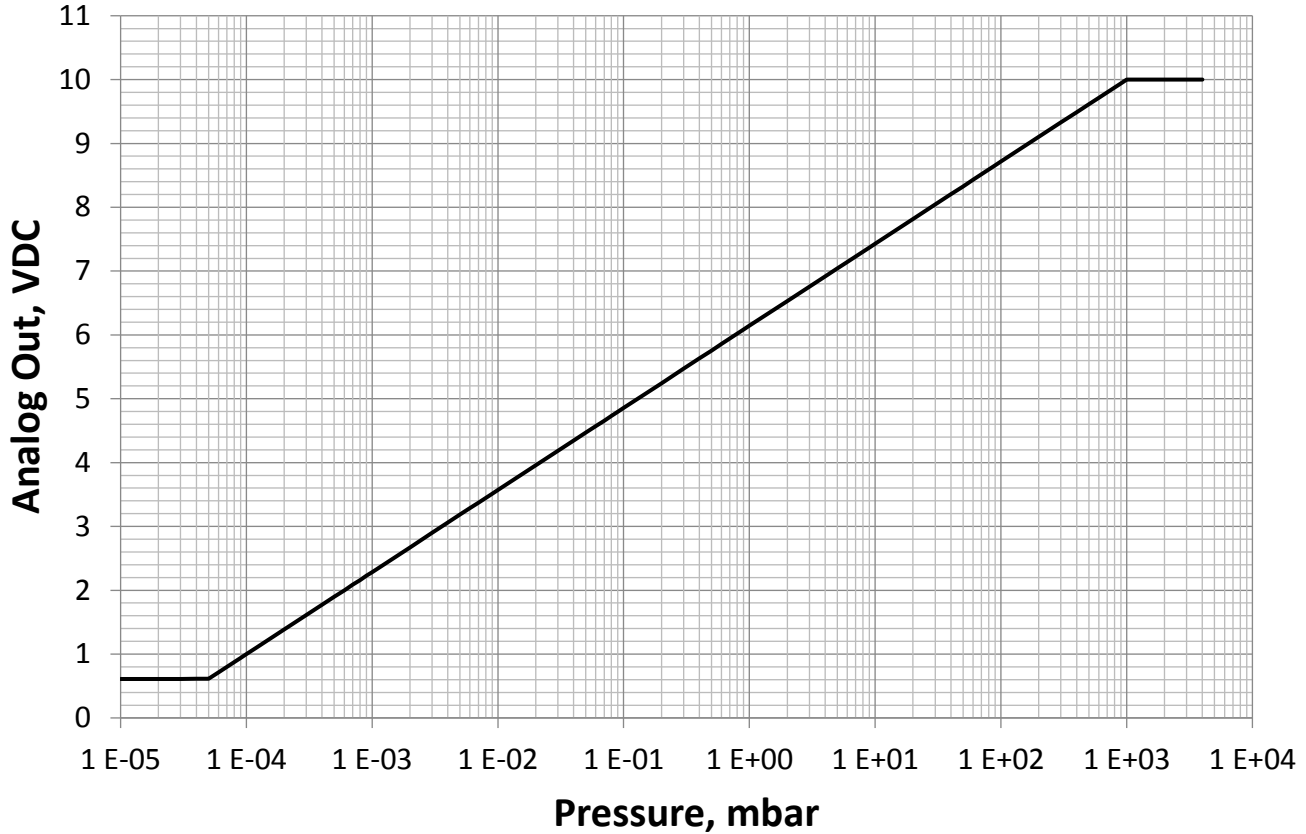

P [mbar]	Analog out [V]	P [mbar]	Analog out [V]	P [mbar]	Analog out [V]	P [mbar]	Analog out [V]
5.00E-05	0.6119	6.00E-03	3.2857	8.00E-01	6.0184	1.00E+02	8.7150
6.00E-05	0.7137	7.00E-03	3.3718	9.00E-01	6.0842	2.00E+02	9.1021
7.00E-05	0.7998	8.00E-03	3.4464	1.00E+00	6.1430	3.00E+02	9.3286
8.00E-05	0.8744	9.00E-03	3.5122	2.00E+00	6.5301	4.00E+02	9.4892
9.00E-05	0.9402	1.00E-02	3.5710	3.00E+00	6.7566	5.00E+02	9.6139
1.00E-04	0.9990	2.00E-02	3.9581	4.00E+00	6.9172	6.00E+02	9.7157
1.20E-04	1.1008	3.00E-02	4.1846	5.00E+00	7.0419	7.00E+02	9.8018
2.00E-04	1.3861	4.00E-02	4.3452	6.00E+00	7.1437	8.00E+02	9.8764
3.00E-04	1.6126	5.00E-02	4.4699	7.00E+00	7.2298	9.00E+02	9.9422
4.00E-04	1.7732	6.00E-02	4.5717	8.00E+00	7.3044	1.00E+03	10.0000
5.00E-04	1.8979	7.00E-02	4.6578	9.00E+00	7.3702		
6.00E-04	1.9997	8.00E-02	4.7324	1.00E+01	7.4290		
7.00E-04	2.0858	9.00E-02	4.7982	2.00E+01	7.8161		
8.00E-04	2.1604	1.00E-01	4.8570	3.00E+01	8.0426		
9.00E-04	2.2262	2.00E-01	5.2441	4.00E+01	8.2032		
1.00E-03	2.2850	3.00E-01	5.4706	5.00E+01	8.3279		
2.00E-03	2.6721	4.00E-01	5.6312	6.00E+01	8.4297		
3.00E-03	2.8986	5.00E-01	5.7559	7.00E+01	8.5158		
4.00E-03	3.0592	6.00E-01	5.8577	8.00E+01	8.5904		
5.00E-03	3.1839	7.00E-01	5.9438	9.00E+01	8.6562		

5.3 Sensor gas dependence

The sensor technology is based on measurement of thermal conductivity and consequently its reading depends on gas and gas concentration.

The transmitter sensor is per factory default calibrated for Nitrogen gas and shown below is the TTR 91 N and TTR 96 N MEMS Pirani reading for different gas types. Be aware that when measuring in environments where other gases than nitrogen (calibration gas) are present, the readings can deviate from the true pressure.

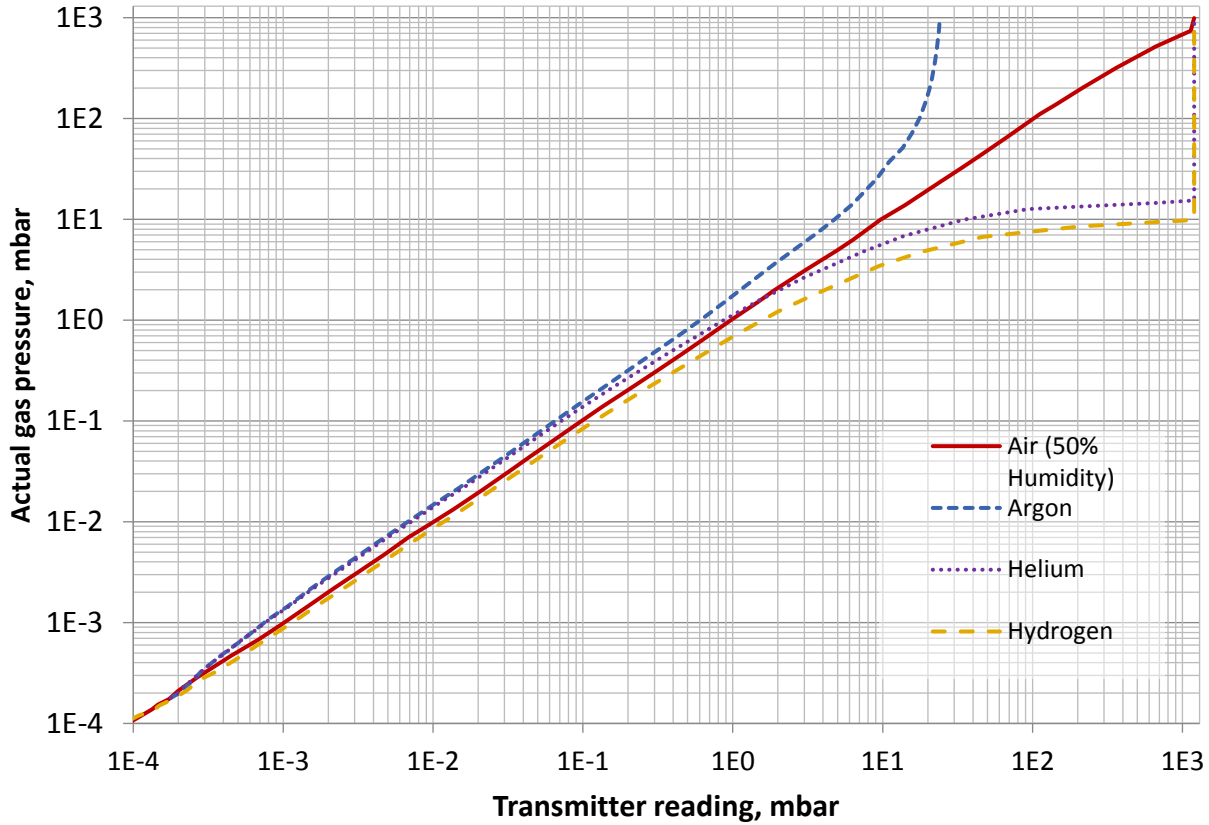

In the range below 1 mbar, the pressure indication is linear. For gases other than air, the pressure can be determined by means of a simple conversion formula:

$$p_{eff} = C \cdot \text{pressure reading}$$

For which:

Gas type	Calibration factor C	Valid range (mbar]
He	1.4	$3 \cdot 10^{-3}$ to 0.3 mbar
Ar	1.57	10^{-3} to 1 mbar
H ₂	0.84	$3 \cdot 10^{-3}$ to 0.2 mbar
Air, O ₂ , CO, N ₂	1	$3 \cdot 10^{-3}$ to 0.3 mbar

These conversion factors are average values.

6 Functions

The user switch, red/green LED-ring/LED status indicator and connector can be found at the top of the transmitter.

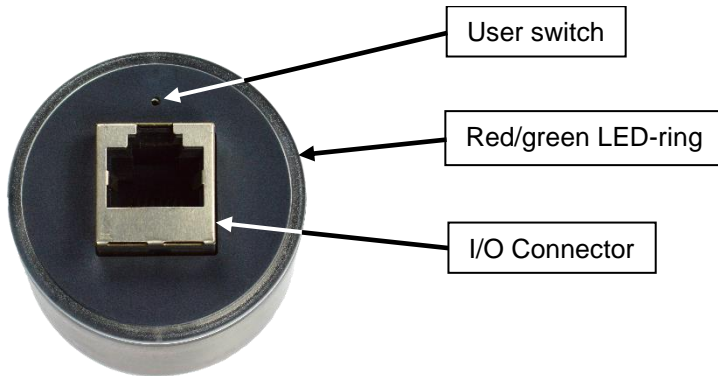

6.1 LED-ring/LED status indicator

The LED-ring/LED will indicate the status of the transmitter by showing a certain color-code:

LED-ring/LED	Transmitter status
Solid green	Normal operation
2 sec. red	Power on sequence
2 sec. red	User switch disabled
Continuously RED	Transmitter defect
Off	Power off
Other	Relates to configuration of vacuum-zero/full-scale adjustment or relay Setpoint adjustment see chapter 6.2.

6.2 Vacuum-zero/full-scale adjustment and setpoint adjustment

It is possible to perform vacuum-zero/full-scale adjustment (Zero/FS) by using the user switch. Setpoint adjustments with the user switch can only be performed for transmitters with P/N: 230040V02 to 230047V02.

Zero adjustment before operation is recommended to obtain best measurement performance in the lowest part of the measuring range. Vacuum-zero adjustment is not required for measurements above 5×10^{-4} mbar. However, drift can occur over time and periodic vacuum-zero adjustments are then recommended to optimize measurement performance.

MEMS Pirani-sensor vacuum-zero/full-scale (Zero/FS) adjustments

The vacuum-zero adjustment function changes the MEMS Pirani measurement offset at low pressure. Temporary or permanent shift in zero offset can be caused by contamination, corrosion, electrical noise interference and temperature.

The MEMS Pirani full scale adjustment allows the user to adjust the MEMS Pirani full scale reading Atmospheric adjustment can only be executed with air or Nitrogen.

It is possible to perform vacuum-zero/full-scale adjustments of the MEMS Pirani-sensor P by using the user switch. See chapter 6.3.



Attention

To obtain best measuring performance, it is recommended that the transmitter is evacuated to a pressure below 1×10^{-5} mbar before executing zero adjustment of the MEMS Pirani sensor. Zero adjustment of the MEMS Pirani sensor can be executed at pressures higher than 1×10^{-5} mbar, but this can cause inaccurate reading.



If the pressure measured by the transmitter is higher than approximately 1×10^{-2} mbar, then the zero adjustment cannot be executed. If the zero adjustment failed, the LED-ring/LED will flash red three times.



Attention

Zero adjustment only changes the low measuring range and will have no influence on measuring errors in the range from 1×10^{-2} mbar and above.



Atmospheric adjustment only changes the high measuring range and will have no influence on measuring errors in the range below 10 mbar.



Caution

Before performing the atmospheric adjustment, vent transmitter to Nitrogen or air pressure of 1000 mbar. The transmitter will only accept full-scale adjustment when the pressure readout is within 600 to 1000 mbar. Note that if the adjustment is performed at a true pressure different from 1000 mbar, it can cause measurement deviations in the upper part of the measuring range.

6.3 User switch adjustments

The user switch-button can be pressed (as seen below) by using the adjusting-pin that is added in the transmitter package or by using another pin with similar shape (Ø 1mm).

The color of the LED-ring/LED will indicate the status of the transmitter during user switch adjustments:

Transmitter status	LED-ring/LED color
Normal operation	Solid green
Vacuum-zero/Full-scale adjustment	Pulsing between red and green
Setpoint 1 adjustment*	Pulsing green
Setpoint 2 adjustment*	Pulsing red

*The setpoint adjustment is only available for transmitters with user switch adjustable setpoints (P/N: 230040V02, 230043V02, 230045V02, 230047V02.)

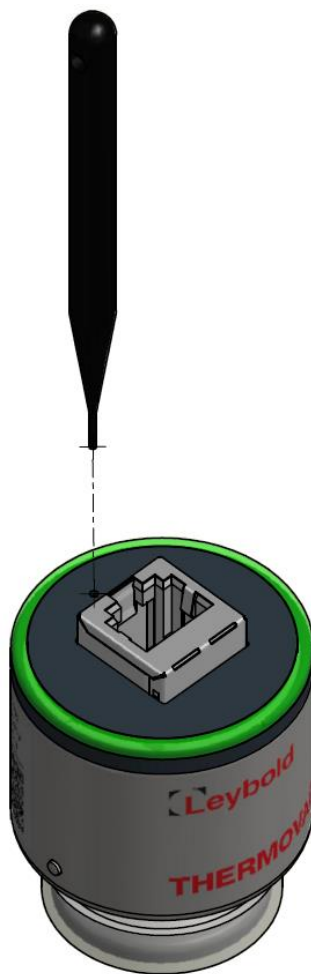

To change the transmitter from normal operation to one of the adjustment-modes, use the following guiding diagram:

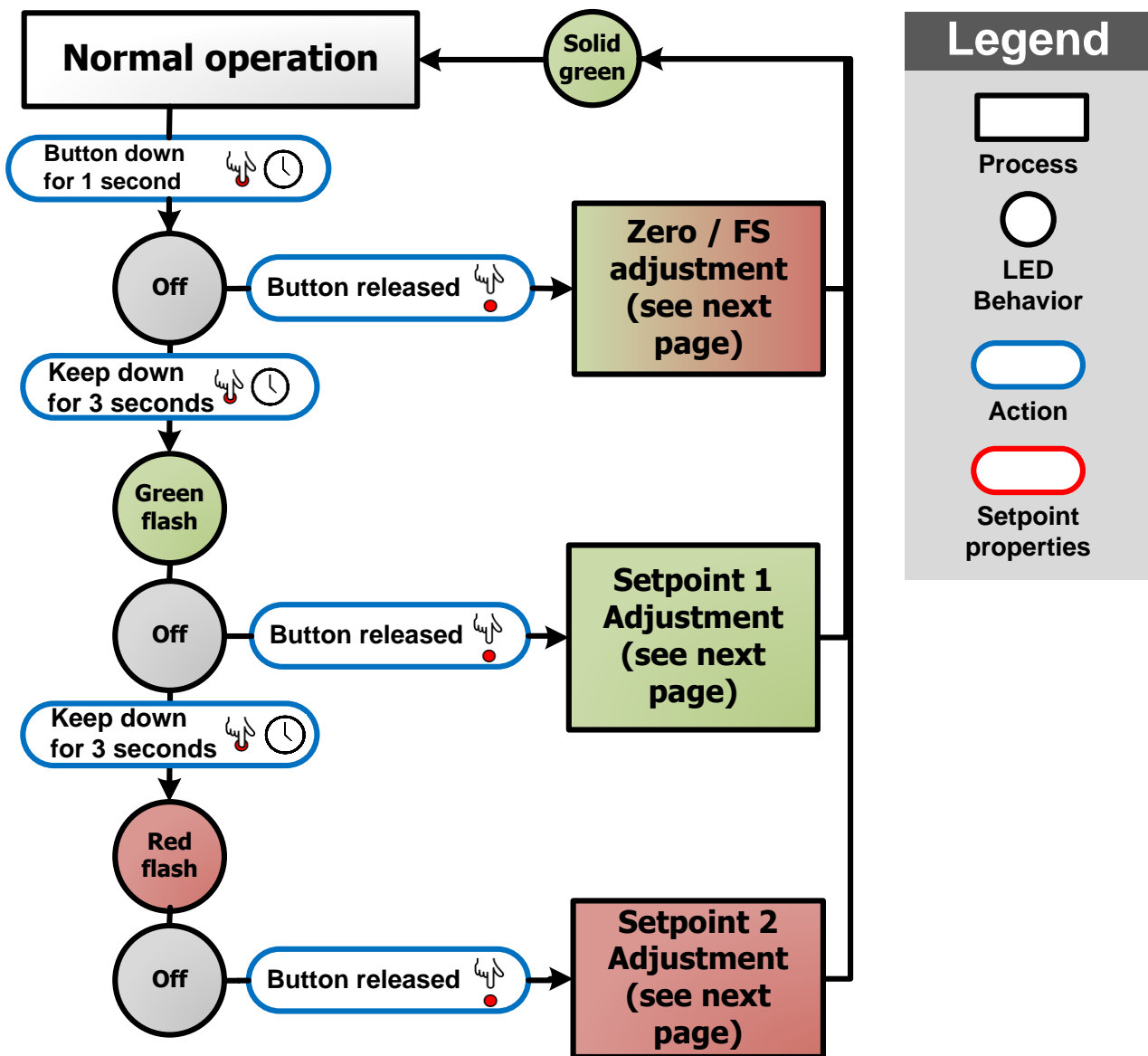

To further adjust in either the Vacuum-zero/Full-scale adjustment mode or the Setpoint adjustment mode, use the following guiding diagram:

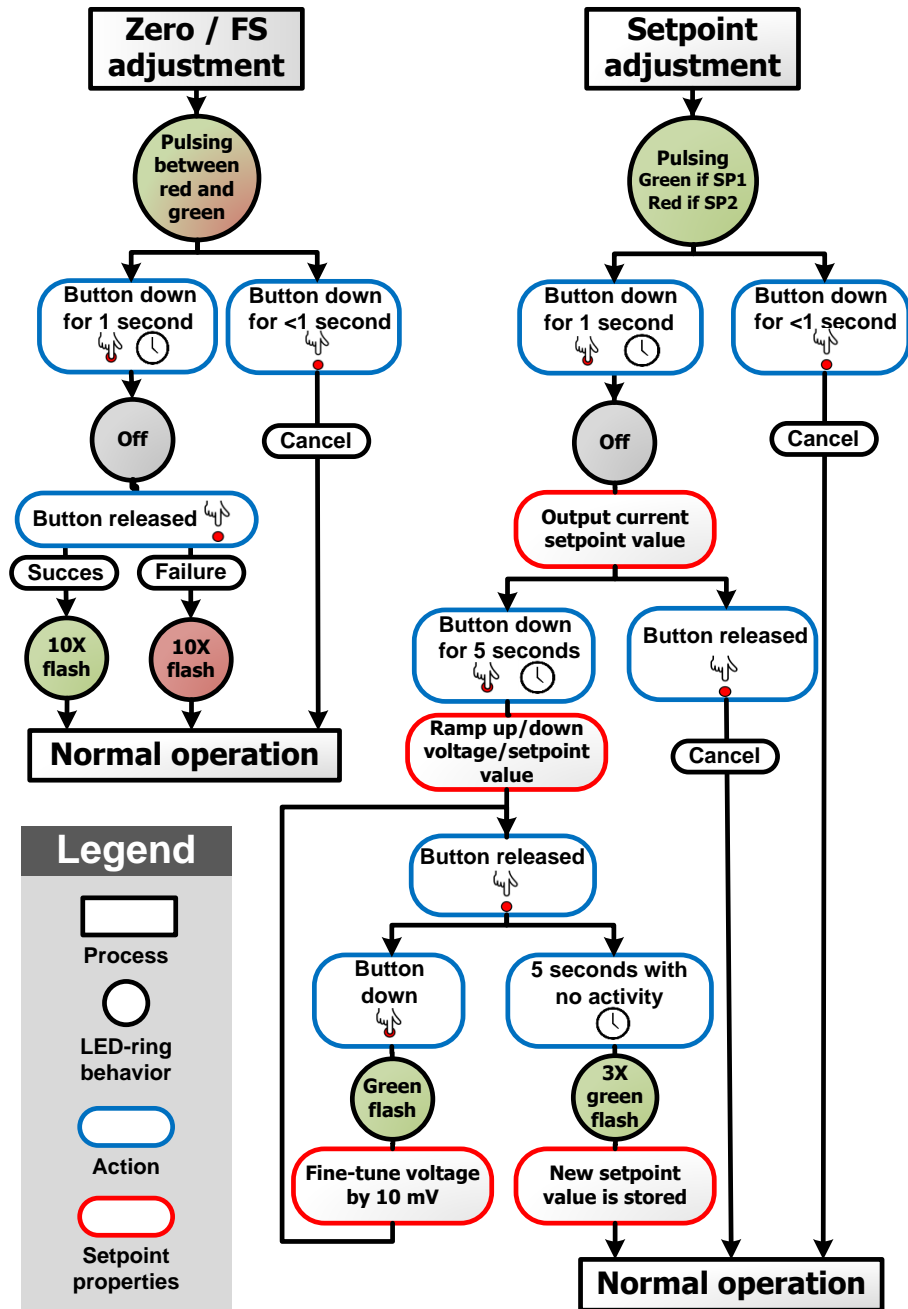

Setpoint adjustment:

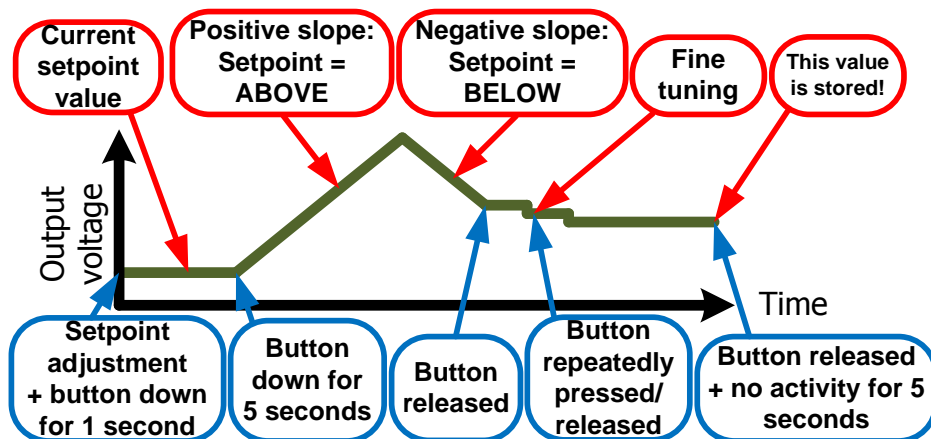

All steps from Normal operation to the different adjustment modes and related adjusting steps can also be found in the following guide:

Adjustment	User switch and LED-ring/LED action			
Zero/FS adjustment	Press button for 1 second until light ring is off			
	Release button to enter Zero/FS adjustment mode			
	Light ring is pulsing red and green			
	Press button >1 second to perform Zero/FS adjustment		Press button <1 second to go back to Normal Operation	
	LED-ring/LED is off			
	Release button			
	LED-ring/LED flashes green 10 times: Zero/FS adjustment succeeded	LED-ring/LED flashes red 10 times: Zero/FS adjustment failed		
Setpoint 1 adjustment	Press button for 1 second until light ring is off			
	Continue pressing button for 3 seconds until light ring shows single green flash			
	Release button to enter Setpoint 1 adjustment			
	LED-ring/LED is pulsing green			
	Press button for >1 second		Press button <1 second to go back to Normal Operation	
	LED-ring/LED is off			
	Output current setpoint value			
	Continue pressing button for >5 seconds			Release button to keep current voltage output threshold to Analog output and return to Normal operation
	Ramp up/down voltage/setpoint value			
	Release button to keep current voltage output threshold to Analog output			
	Tap button to toggle through Output voltage with small increments of 10 mV	Wait for >5 seconds		
	LED-ring/LED flashes green			
	Wait for >5 seconds			
LED-ring/LED flashes green 3 times				
Selected Output voltage is stored				
Setpoint 2 adjustment	Press button for 1 second until light ring is off			
	Continue pressing button for 6 seconds until light ring shows single red flash			
	Release button to enter Setpoint 2 adjustment			
	LED-ring/LED is pulsing red			
	Press button for >1 second		Press button <1 second to go back to Normal Operation	
	LED-ring/LED is off			
	Output current setpoint value			
	Continue pressing button for >5 seconds			Release button to keep current voltage output threshold to Analog output and return to Normal operation
	Ramp up/down voltage/setpoint value			
	Release button to keep current voltage output threshold to Analog output			
	Tap button to toggle through Output voltage with small increments of 10 mV	Wait for >5 seconds		
	LED-ring/LED flashes green			
	Wait for >5 seconds			
LED-ring/LED flashes green 3 times				
Selected Output voltage is stored				

7 FAQ (Frequently Asked Questions)

Applications

Q: *Can the transmitter and sensor element continuously withstand vibrations from mechanical fore-pump?*

A: Yes – The MEMS sensor element can withstand continuous vibrations.

Q: *Is the transmitter compatible with fluorine gases?*

A: No – The transmitter is not intended for use in aggressive environments, like semiconductor etch applications. However, the sensors coated with Parylene-HT® offer better resistance against various corrosive gases compared to the standard MEMS Pirani. Refer to chapter 3.3.

Q: *When the transmitter is pumped down and isolated by closing a valve the pressure is rising. Is the transmitter leaking?*

A: Not likely - When a confined space is evacuated and the pumping is stopped the pressure will rise because of outgassing mainly by water vapor. The pressure can easily rise to a few mbar over time.

Q: *When the transmitter is leak checked on a helium leak detector. Leak reading is building up slowly after approximately 30 seconds. Is the transmitter leaking?*

A: No - The internal sealing of the transmitter uses elastomer FPM sealing and consequently helium molecules can penetrate through the FPM material and cause slow increase of helium leak readout. If a leaking transmitter is tested directly on a helium leak detector the leak is almost instantly displayed.

Q: *Can the transmitter be mounted in any orientation?*

A: Yes - The transmitter can be mounted in any orientation without compromise of performance or calibration. However, it's recommended not to mount the transmitter with the flange port facing upwards to avoid contamination, like particulates or liquids, from entering the device.

Q: *Can the transmitter withstand instant ventilation?*

A: Yes - The sensor element is extremely robust to mechanical forces and can withstand continuous pressure cycles and instant air ventilation.

Q: *Can I connect a valve to be controlled by the transmitter relay contact?*

A: Driving inductive loads such as valves requires special precautions. Refer to chapter 4.2.

Q: *How many pressure cycles can the transmitter withstand?*

A: The sensor element is very robust to pressure changes and the number of pressure cycles will have no effect on the lifetime of the transmitter.

Analog output

Q: *What is the update rate of the analog output?*

A: 16 times per second.

Q: *What is the maximum length of analog output cable?*

A: The length of analog cable depends on cable quality and electrical noise environment, but a cable length up to 100 m do normally not require any special precautions other than cable must be screened.

Q: *How long is the waiting time from turning power on to valid measuring values?*

A: The power on sequence is approximately 2 seconds. The light ring is illuminating red during power up sequence. Reliable measurements are typically available within 1 minute.

Calibration and adjustment

Q: *How often does the transmitter require calibration or Zero adjustment?*

A: It depends on the application and pressure range. In many applications user adjustment is never required. Factors that temporally or permanent can influence the measuring performance is contamination, corrosion, heat and electronic interference.

Q: *Will the transmitter retain user calibration after power is shut off?*

A: Yes - All transmitter parameters including calibration data is stored internally in the transmitter nonvolatile memory.

Service and repair

Q: *+24 VDC supply voltage has been connected to analog output+. Is the transmitter damaged?*

A: Likely - The analog output is not protected against applying power to the output pin.

Q: *Reverse voltage has been connected to power supply input. Is the transmitter damaged?*

A: Not likely – The transmitter power supply circuit has reverse voltage and over voltage protection however, Leybold cannot guarantee that the transmitter will not be damaged.

Q: *The status light ring is constantly illuminating red?*

A: The red status indicates a defect sensor element most likely damaged by corrosion or contamination. It can also occur if electronics malfunction.

8 Trouble shooting

Symptom	Possible Cause/Remedy
Incorrect pressure value	<ul style="list-style-type: none"> - Other gas present than transmitter gas setting or trace of gas. - Contaminated sensor. - Corroded sensor. - Perform a zero adjustment/FS adjustment. - Check Setting of Controller or display.
Incorrect pressure value at low pressure	<ul style="list-style-type: none"> - Contaminated sensor. - Corroded sensor. - Incorrect zero adjustment has been executed. - Transmitter exposed to heat or cooling air stream. - Perform a zero adjustment.
Incorrect pressure value at high pressure	<ul style="list-style-type: none"> - Contaminated sensor. - Corroded sensor. - Incorrect atmospheric adjustment has been executed. - Other gas or gas trace present than transmitter gas setting. - Perform a full-scale adjustment.
Set point relay does not trip	<ul style="list-style-type: none"> - Setpoint not enabled. - Setpoint value not set to proper value. - Setpoint direction is different than the user expects. - Check electrical connection. - Check part number to see if transmitter has setpoint relays.
No analog output	<ul style="list-style-type: none"> - Power supply turned off. - Check electrical connections.
Status light ring illuminating red	<ul style="list-style-type: none"> - Sensor element defect.

9 Declaration of Contamination

Safety information on contamination of compressors, vacuum pumps and components.

Scope:

Every employer (user) is held responsible for the health and safety of his employees. This also applies to service personnel performing maintenance work either at the premises of the user or the service company in charge.

By means of the declaration attached the contractor is to be informed about any possible contamination of the compressor, vacuum pump or component sent in for servicing. Based on this information the contractor will be able to take the necessary safety precautions.

Preparation before dispatch

Before shipping any parts, the user must complete the following declaration and add it to the dispatch papers. All dispatch instructions laid down in the manual must be followed e.g.:

- Drain all service fluids
- Remove filter elements
- Seal all openings airtight
- Pack / handle appropriately
- Attach the declaration of contamination outside of the packaging

Declaration of Contamination of Compressors, Vacuum Pumps and Components

The repair and / or servicing of compressors, vacuum pumps and components will be carried out only if a correctly completed declaration has been submitted. Non-completion will result in delay. The manufacturer can refuse to accept any equipment without a declaration.

A separate declaration has to be completed for each single component.

This declaration may be completed and signed only by authorized and qualified staff.

Customer/Dep./Institute : _____ Address : _____ _____ Person to contact: _____ Phone : _____ Fax: _____ End user: _____	Reason for return: <input checked="" type="checkbox"/> applicable please mark Repair: <input type="checkbox"/> chargeable <input type="checkbox"/> warranty Exchange: <input type="checkbox"/> chargeable <input type="checkbox"/> warranty <input type="checkbox"/> Exchange already arranged / received Return only: <input type="checkbox"/> rent <input type="checkbox"/> loan <input type="checkbox"/> for credit Calibration: <input type="checkbox"/> DKD <input type="checkbox"/> Factory-calibr. <input type="checkbox"/> Quality test certificate DIN 55350-18-4.2.1
--	--

A. Description of the Leybold product: Material description : _____ Catalog number: _____ Serial number: _____ Type of oil (ForeVacuum-Pumps) : _____	Failure description: _____ Additional parts: _____ Application-Tool: _____ Application- Process: _____
--	---

B. Condition of the equipment	No ¹⁾	Yes	No		Contamination :	No ¹⁾	Yes
1. Has the equipment been used	<input type="checkbox"/>	<input type="checkbox"/>	<input type="checkbox"/>	→	toxic	<input type="checkbox"/>	<input type="checkbox"/>
2. Drained (Product/service fluid)	↓	<input type="checkbox"/>	<input type="checkbox"/>		corrosive	<input type="checkbox"/>	<input type="checkbox"/>
3. All openings sealed airtight	↓	<input type="checkbox"/>	<input type="checkbox"/>		flammable	<input type="checkbox"/>	<input type="checkbox"/>
4. Purged		<input type="checkbox"/>	<input type="checkbox"/>		explosive ²⁾	<input type="checkbox"/>	<input type="checkbox"/>
If yes, which cleaning agent _____					radioactive ²⁾	<input type="checkbox"/>	<input type="checkbox"/>
and which method of cleaning _____					microbiological ²⁾	<input type="checkbox"/>	<input type="checkbox"/>
¹⁾ If answered with "No", go to D. ←					other harmful substances	<input type="checkbox"/>	<input type="checkbox"/>

C. Description of processed substances (Please fill in absolutely)

1. What substances have come into contact with the equipment ?
 Trade name and / or chemical term of service fluids and substances processed, properties of the substances
 According to safety data sheet (e.g. toxic, inflammable, corrosive, radioactive)

X	Tradename:	Chemical name:
a)		
b)		
c)		
d)		

2. Are these substances harmful ? No Yes ←

3. Dangerous decomposition products when heated ? No Yes ←

If yes, which ? _____

²⁾ Components contaminated by microbiological, explosive or radioactive products/substances will not be accepted without written evidence of decontamination.

D. Legally binding declaration
 I / we hereby declare that the information supplied on this form is accurate and sufficient to judge any contamination level.

Name of authorized person (block letters) : _____

_____ Date _____ signature of authorized person firm stamp

10 Declaration of Conformity



EU Declaration of Conformity

(Translation of original Declaration of Conformity)

The manufacturer: Leybold GmbH
Bonner Strasse 498
D-50968 Köln
Germany

herewith declares that the products specified and listed below which we have placed on the market, comply with the applicable EU Council Directives. This declaration becomes invalid if modifications are made to the product without agreement of Leybold GmbH.

Product designation: THERMOVAC Transmitter

Type designation: TTR 81 N, TTR 91 N, TTR 96 N, TTR 911 N, TTR 916 N,
TTR 101 N, TTR 200 N

Part numbers: 230035V02, 230036V02, 230037V02, 230038V02, 230040V02,
230043V02, 230045V02, 230047V02, 230280S02, 230280V02,
230350V02, 230351V02, 230352V02, 230353V02, 230354V02,
230355V02, 230356V02, 230358V02, 230365V02, 230366V02,
89650V02, 89654V02, 89656V02, 89659V02, 89660V02,
230700V02*, 230701V02*, 230702V02*

The products complies to the following European Council Directives:

Electromagnetic Compatibility (2014/30/EU)

The following harmonized standards have been applied:

EN 61326-1:2013 Electrical equipment for measurement, control and laboratory use —
EMC requirements — Part 1: General requirements
Immunity: controlled EM environments

EN 55011:2009/A1:2010 Industrial, scientific and medical equipment — Radio-frequency
disturbance characteristics — Limits and methods of measurement
Group 1, Class B (* Class A)

Cologne, November 16, 2016

Cologne, November 16, 2016



ppa. Martin Tollner
Head of Product Lines



ppa. Dr. Monika Mattern-Klosson
Head of Quality & Business Process Management

Document No.: 300570977-002-A1