



OPERATING INSTRUCTIONS

EN

Translation of the original instructions

MVP 010-3 DC

Diaphragm Pumps

Chemtech Scientific provides access to this content as a courtesy.
We do not own the content contained in this document.
All rights and credit go directly to its rightful owners.
www.chemtechsci.com
Call us at: 484-424-9415



Table of contents

1	About this manual	3
	1.1 Validity	3
	1.2 Conventions	3
2	Safety	5
	2.1 Safety precautions	5
	2.2 Proper use	6
	2.3 Improper use	6
3	Product description	7
	3.1 Product identification	7
	3.2 Function	7
4	Transport and storage	8
	4.1 Transport	8
	4.2 Storage	8
5	Installation	9
	5.1 Setting up the pump	9
	5.2 Connecting the vacuum side	9
	5.3 Connecting the exhaust side	9
	5.4 Connection	10
6	Operation	15
	6.1 Before switching on	15
	6.2 Commissioning	15
	6.3 Operation modes	15
	6.4 Switching on the pump	16
	6.5 Switching off	16
	6.6 The Pfeiffer Vacuum parameter set	17
7	Pfeiffer Vacuum Protocol for "RS-485"	22
	7.1 Telegram frame	22
	7.2 Telegrams	22
	7.3 Applied data types	23
8	Maintenance	24
	8.1 Precautions	24
	8.2 Cleaning and replacing diaphragms and valves	26
9	Decommissioning	28
	9.1 Shutting down for longer periods	28
10	Malfunctions	28
	10.1 Rectifying malfunctions	29
	10.2 Error codes	29
11	Service	30
12	Spare parts	31
13	Accessories	31
14	Technical data and dimensions	32
	14.1 General	32
	14.2 Technical data	33
	14.3 Substances in contact with the media	33
	14.4 Dimensions	34
	Declaration of conformity	35

1 About this manual

1.1 Validity

This operating manual is for customers of Pfeiffer Vacuum. It describes the functioning of the designated product and provides the most important information for safe use of the unit. The description follows applicable EU guidelines. All information provided in this operating manual refers to the current state of the product's development. The documentation remains valid as long as the customer does not make any changes to the product.

Up-to-date operating instructions can also be downloaded from www.pfeiffer-vacuum.com.

Applicable documents

MVP 010-3 DC	Operating instructions
Declaration of Conformity	Part of this document
Operating instructions for accessories (order-specifically)	see section "accessories"

*also available via www.pfeiffer-vacuum.com

For information about other certifications, if applicable, please see the signet on the product or:

- www.tuvdotcom.com
- TUVdotCOM-ID 0000021320

1.2 Conventions

Safety instructions

The safety instructions in Pfeiffer Vacuum operating instructions are the result of risk evaluations and hazard analyses and are oriented on international certification standards as specified by UL, CSA, ANSI Z-535, SEMI S1, ISO 3864 and DIN 4844. In this document, the following hazard levels and information are considered:

DANGER
<p>Imminent danger Indicates an imminent hazardous situation that will result in death or serious injury.</p>
WARNING
<p>Possibly imminent danger Indicates an imminent hazardous situation that can result in death or serious injury.</p>
CAUTION
<p>Possibly imminent danger Indicates an imminent hazardous situation that can result in minor or moderate injury.</p>
NOTICE
<p>Command or note Command to perform an action or information about properties, the disregarding of which may result in damage to the product.</p>

Pictographs



Prohibition of an action to avoid any risk of accidents, the disregarding of which may result in serious accidents



Warning of a displayed source of danger in connection with operation of the unit or equipment



Command to perform an action or task associated with a source of danger, the disregarding of which may result in serious accidents



Important information about the product or this document

Instructions in the text

→ Work instruction: here you have to do something.

Symbols used

The following symbols are used consistently throughout in all illustrations:

- Ⓟ Vacuum connection
- Ⓛ Exhaust
- Ⓢ Gas ballast valve
- Ⓣ Power connection

2 Safety

2.1 Safety precautions



Duty to inform

Each person involved in the installation, operation or maintenance of the vacuum pump must read and observe the safety-related parts of these operating instructions.

→ The operator is obligated to make operating personnel aware of dangers originating from the vacuum pump, the pumped medium and the entire system.



Installation and operation of accessories

Pfeiffer Vacuum pumps can be equipped with a series of adapted accessories. The installation, operation and maintenance of connected devices are described in detail in the operating instructions of the individual components.

→ For information on order numbers of components, see "Accessories".

→ Use original accessory parts only.

- Before pumping dangerous, corrosive or environmentally hazardous media, take suitable precautions:
 - Test the compatibility with substances in contact with the media.
 - Prevent the release of process gases and their reaction products and by-products or dispose of them according to the relevant regulations.
 - Safety measures (e.g. wearing protective clothing and safety goggles) to prevent inhalation and skin contact.
- **Power supply:** The vacuum pump power supply must apply to the requirements of double insulation between mains input voltage and operating voltage according to the regulations of IEC 61010 and IEC 60950. Therefore Pfeiffer Vacuum recommends to use exclusively original-power packs and -accessories. Only in this case Pfeiffer Vacuum is able to guarantee the compliance of the European and North American guidelines.
 - The **maximum short-circuit current of 45 A** of the voltage source/power supply must not be exceeded!
- A safe connection to the protective earthing conductor (PE) is recommended (protection class III).
- Do not expose any body parts to the vacuum.
- Observe the safety and accident prevention regulations.
- Check regularly that all safety precautions are being complied with.
- Do not carry out any unauthorised modifications or conversions to the pumps.
- Depending on the operating and ambient conditions, the surface temperature of the pumps may rise above 70 °C. Use suitable finger guards if necessary.
- When returning the pumps to us please note the instructions in the Service section.

2.2 Proper use



NOTICE

EC conformity

The manufacturer's declaration of conformity becomes invalid if the operator modifies the original product or installs additional components.

→ Following installation into a plant and before commissioning, the operator must check the entire system for compliance with the valid EU directives and reassess it accordingly.

- The vacuum pump may only be used to generate a vacuum.
- Installation, operating and maintenance regulations must be complied with.
- Other accessories, than those described in this manual, must not be used without the agreement of Pfeiffer Vacuum.

2.3 Improper use

Improper use will cause all claims for liability and warranties to be forfeited. Improper use is defined as usage for purposes deviating from those mentioned above, especially:

- pumping of corrosive gases
- pumping of explosive media
- operation in potentially explosive areas
- pumping of gases containing impurities such as particles, dusts and condensate; note the vapour compatibility levels of the pump
- pumping of substances that tend to sublime
- use of the vacuum pump to generate pressure
- pumping of liquids
- connection to pumps or units which are not suitable for this purpose according to their operating instructions
- connection to units which have exposed voltage-carrying parts

3 Product description

3.1 Product identification

To correctly identify the product when communicating with Pfeiffer Vacuum, always have the information from the rating plate available.

- Pump model and model number
- Serial number
- Date of manufacture

Scope of delivery

- Pump with drive unit
- Silencer
- Operating instructions
- Dummy plug on the vacuum connection

3.2 Function

The diaphragm vacuum pumps of the series MVP 010-3 DC are dry compressor vacuum pumps with 4 pump stages. The pumps are positive displacement pumps with a periodic change of size of the suction chamber produced by the movement of the diaphragm. The gas flow causes the valves to open and close automatically. The pump units are directly connected to the drive motor.

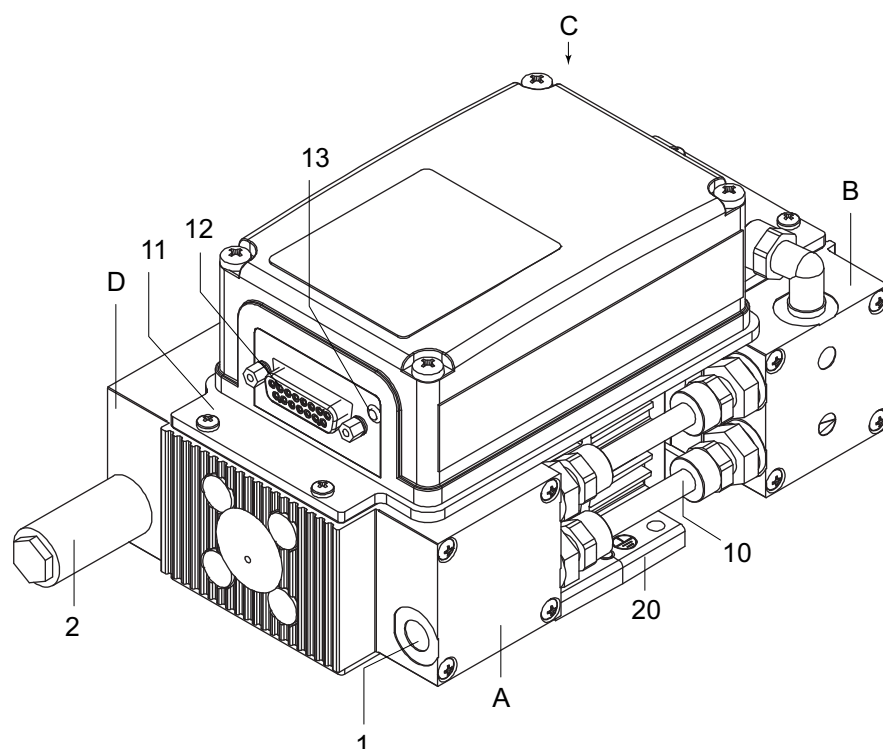

Fig. 1: MVP 010-3 DC

A	Diaphragm head 1	1	Vacuum connection, G 1/8"	13	LED
B	Diaphragm head 2	2	Exhaust with silencer, G 1/8"	12	Connecting plug
C	Diaphragm head 3	10	Hose connection	20	Fixing plate
D	Diaphragm head 4	11	Cover		

4 Transport and storage

4.1 Transport

- Lift pump by hand at both face sides.
 - Do not use the hose connection to carry the pump.

4.2 Storage

- Check that all the openings on the pump are securely closed.
- Store the pump in a cool, dry place; preferably at room temperatures (approx. 20 °C).
 - For a longer period of storage, seal the pump in a PE bag with drying agents enclosed.

5 Installation

5.1 Setting up the pump

Observe the following requirements when setting up the pump:

- Always place the pump on a firm, even surface.
 - Where stationary installation is involved, anchor the pump on site.
- Consider the load-bearing capacity of the installation site.
- When installing the pump in a closed housing, ensure there is sufficient air circulation.
 - Technical information given on the motor rating plate must be visible.

Installation

conditions

The pump MVP 010-3 DC must be installed and operated under the following ambient conditions:

Installation location	weather protected (indoors)
Protection category	IP 20
Installation altitude	Max. 2000 m above m.s.l., if vacuum pump is installed above 1000 m above mean sea level check compatibility with applicable safety requirements, e.g. DIN EN 61010 (motor may overheat due to insufficient cooling).
Ambient temperature	5-40 °C
Relative humidity	80 % at T ≤ 31 °C, up to max. 50% at T ≤ 40 °C
Degree of pollution	2
Overvoltage category	II

5.2 Connecting the vacuum side

- Remove locking cap on intake connection and connect vacuum pump to the apparatus.
- The connection between the pump and the recipient should be kept as short as possible and should have at least the nominal diameter of the vacuum connection.
 - Depending on the nominal diameter, use PVC hoses or metallic hoses with flange connections.

5.3 Connecting the exhaust side



CAUTION

High pressure in the exhaust line!

Danger of damage to the seals and danger of the pump bursting.

- Install the line without shut-off valves on the exhaust side.
- Do not operate the pump with excess pressure at the inlet; observe the maximum allowable pressures and pressure differences.

- Mount the silencer on the exhaust;
 - alternatively, connect the exhaust line.
- Choose the cross-section of the exhaust line to be at least the size of the nominal connection diameter of the vacuum pump's exhaust connection.
- Lay piping from the pump sloping downward so that no condensate can flow back into the pump; otherwise fit a condensate separator.
 - If an air trap is created in the system, then a device for draining condensation water must be provided at the lowest point.



WARNING
<p>Emission of toxic substances from the exhaust!</p> <p>Danger of poisoning from emitted gases or vapours, which can be detrimental to health and/or can pollute the environment, depending on the particular application.</p> <ul style="list-style-type: none"> → Comply with the applicable regulations when working with toxic substances. → Only officially approved filter systems may be used to separate and remove these substances.

5.4 Connection

→ Shielded connectors and cables must be used.



NOTICE
<p>Danger of the device being destroyed</p> <p>If the plug connection is broken while the voltage supply is switched on, this may result in damage to the electronics.</p> <ul style="list-style-type: none"> → It is imperative to isolate the voltage supply before unplugging the connector. → Switch off the power supply unit.

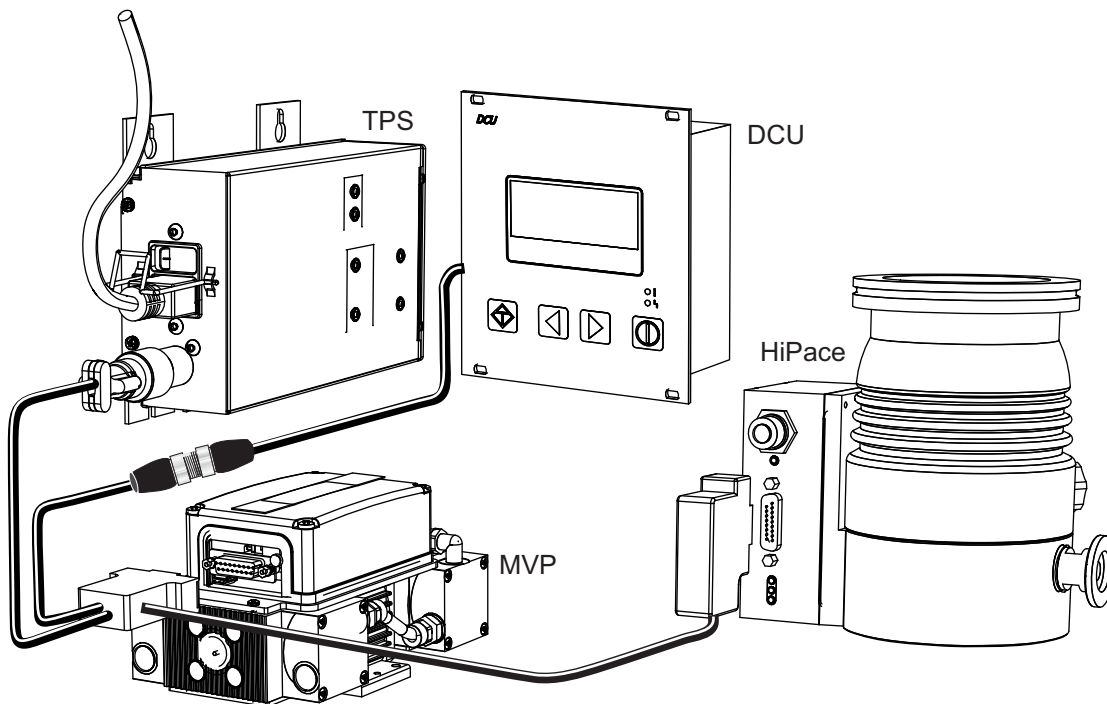

Fig. 2: MVP 010-3 DC connection (connecting cable: PE 100 013)

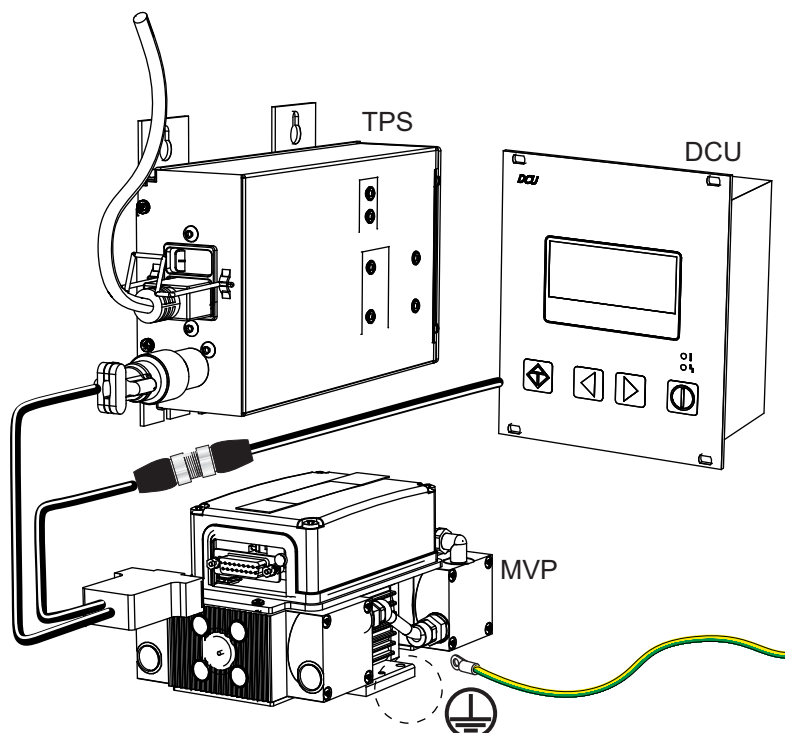

Fig. 3: MVP 010-3 DC connection (connecting cable: PM 061 350 -T)

Pin	Function	Description, factory setting
1	+24 VDC input	Voltage supply for drive and interface
2	DI access request	V+ : Control via DIs, ->GND/open: Control unlocked
3	DI1	V+ : Speed control mode, ->GND/open: no speed control mode
4	DI2	Only valid for pumps with solenoid valve, then applies: V+ : Valve released, ->GND/open: Valve closed
5	DI pumping station	V+ : Pump on, ->GND/open: Pump off
6	DI standby	V+: standby, ->GND/open: no standby
7	V+	24 V output
8	DO1	GND: Error, V+: no error
9	DO2	GND: Target speed not reached, V+: Target speed reached
10	n/c	
11	n/c	
12	n/c	
13	RS-485	D+
14	RS-485	D-
15	Ground (GND)	Ground connection for the voltage supply; Reference ground for all digital inputs and outputs

Table 1: Connector pin arrangement: Simple pump interface (sub-D socket, 15-pin)

Earthing

Pfeiffer Vacuum recommends to connect an appropriate earthing wire to derive applicative interferences.

Voltage supply

+24 V DC input / pin1

The voltage supply is delivered via a connecting cable from the Pfeiffer Vacuum accessory range or by the customer.

+24V DC: **Pin 1**

Ground (GND): **Pin 15**

+24 V DC* Output / Pin 7

Inputs 2 - 6 are activated by connecting them with +24 V DC to Pin 7 (active high). They can also be activated via an external PLC. The functions are deactivated by "PLC high level" and by "PLC low level".

- PLC high level: +13 V to +33 V
- PLC low level: -33 V to +7 V
- Ri: 7 k Ω
- $I_{\max} < 200$ mA (with RS-485, if existing)

Inputs

The digital inputs are used to switch various functions in the electronic drive unit.

DI remote priority / pin2

V+ : The connection has control over all other digital inputs.

open: Remote priority inactive

DI1 (speed control mode) / pin3

V+ : Speed control mode "active"

open: Speed control mode "inactive"

DI2 (valve) / pin4

V+ : Valve "released"

open: Valve "closed"

DI pump / pin5

The pump is switched on and connected components are activated (for instance, purge gas valve) .

V+ : Pump on

open: Pump off

DI standby

The speed can be selected within a range of 30-100 % of the nominal speed.

V+ : Standby activated (speed control mode is "inactive")

open: Standby off, operation at nominal speed

Outputs

The digital outputs at the 15-pin sub-D terminal can withstand a maximum of 24 V / 50 mA per output. All the outputs listed below are configurable with the Pfeiffer Vacuum parameter set via the RS-485 interface (description relates to factory settings).

DO1 (error) / pin8

When the voltage supply has been established, digital output DO1 permanently outputs V+ which means "no error". "Active low" means error (common error message).

V+: no error

GND: Error

DO2 (target speed) / pin9

"Active high" means target speed has been reached. It can, for example, be used for a "pump operational" message.

V+: Target speed reached

GND : Target speed not reached

RS-485

Pin 13 and pin 14 can be used to connect a Pfeiffer Vacuum display and control unit (DCU or HPU) or an external PC.



CAUTION

Danger of electric shock

The insulation measures of the bus system are designed only for use with safety extra-low voltage.

→ Connect only suitable devices to the bus system.

- The group address of the electronic drive unit is 961.
- All units connected to the bus must have differing RS-485 device addresses [**P:797**].

Designation	Value
Serial interface	RS-485
Baud rate	9600 bauds
Data word length	8 bits
Parity	none (no parity)
Start bits	1
Stop bits	1

Connecting Pfeiffer Vacuum display and control units or PC

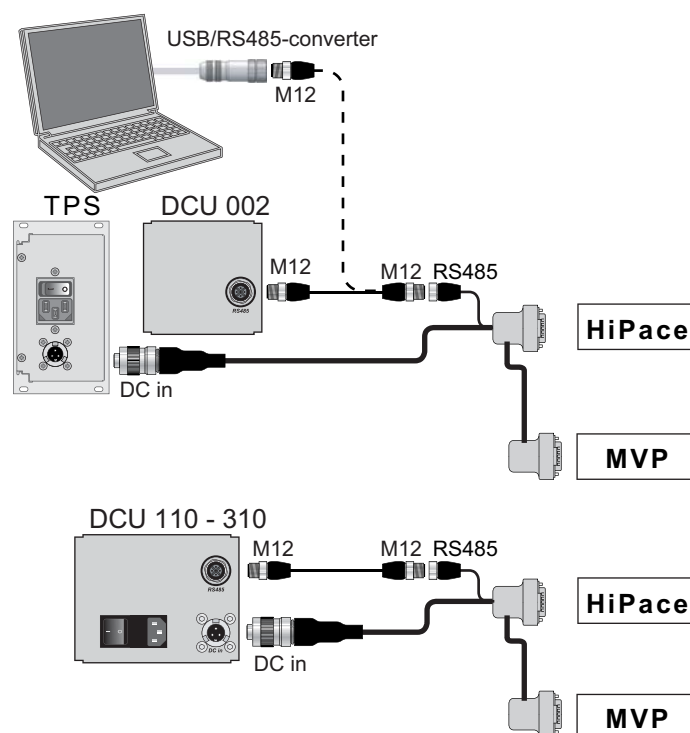

Fig. 4: Optional connection possibilities for interface RS-485

- Use the connection cable supplied with the control panel or from the range of accessories.
- The connection of respectively one external operating unit is possible on the interface RS-485.
- A USB interface (PC) can be connected via the USB/RS-485-converter.

Cross-linking via the connection RS-485

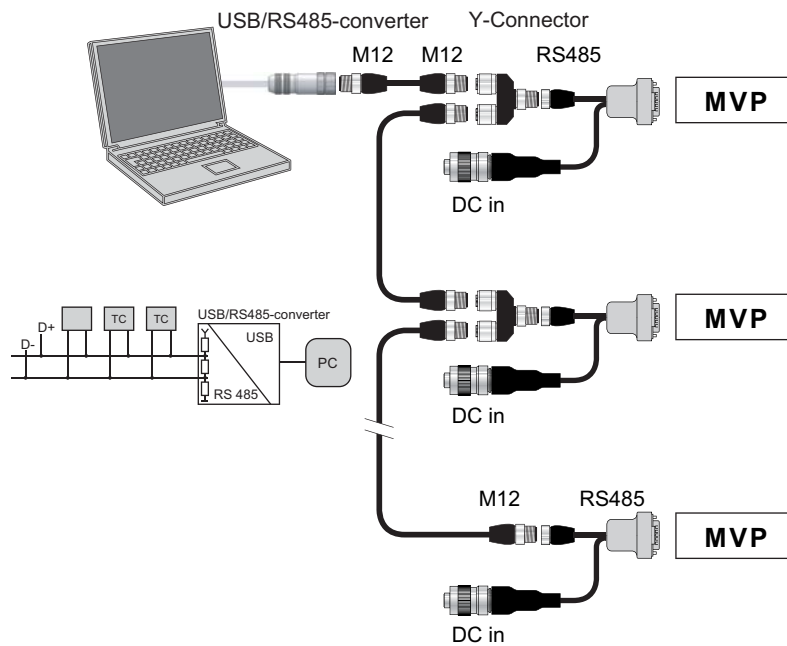

Fig. 5: Optional connection possibilities for interface RS-485

- ➔ Establish the connections according to the specification of the interface RS-485.
- ➔ Connect all units with RS-485 D+ and RS-485 D- to the bus.

Status LED

The monochromatic operation display on the front panel of the Gerates shows the operation status of the electronic drive unit.

Display	Activity	Meaning
Off 	none	– no adequate power supply
Rapid flashing 	10 % active, 1 Hz	– no malfunction – Pump "OFF" – Pump stands still
Flashing 	50 % active, 1 Hz	– no malfunction – Pump "ON" – Pump rotates
Invers rapid flashing 	90 % active, 1 Hz	– no malfunction – Pump "ON" – Set speed not attained
Permanent on 	100 % active	– no malfunction – Pump "ON" – Set speed attained
Flickering 	50 % active, 10 Hz	– Malfunction

6 Operation

6.1 Before switching on

- Compare the voltage information on the rating plate with the supply voltage.
- Check that the exhaust connection allows free flow (max. permissible pressure 1100 hPa absolute).
 - Activate the shut-off valves in such a way that they open before or at the same time as the pump is started.
- Protect the pump sufficiently from taking in contaminants by means of suitable precautions (e.g. dust filters).



CAUTION

Dangerous overpressure overload!

Mixing up the connections leads to a dangerous overpressure overload in the pump, and the motor could be damaged.

- Before commissioning, make sure that no impermissibly high pressure arises on the pressure side.

6.2 Commissioning

The following information display the factory setting. Configuration is possible using the Pfeiffer Vacuum parameter set.

- Parameter [P:707] Set value in rotation speed setting mode: 100 % of the nominal rotation speed

6.3 Operation modes

The following operation modes are available:

- Operation without operating unit
- Operation via an external controller
- Operation via RS-485 and Pfeiffer Vacuum display and control units or PC

Operation without operating unit



CAUTION

Automatic start

After bridging the contacts on the connection plug "X3" or using a connecting cable "with the respective bridges" **and setting up** the supply voltage, the pump will run up immediately.

- Switch on the mains supply until immediately before operation.

- Attach an appropriate connecting cable with jumpers to the cable connector.
- Switch on the supply voltage with switch S1 on the power supply.

After the operating voltage is applied, the pump performs a self-test to check the supply voltage. The pump is started once the self-test has been successfully completed.

Operation via an external controller

The remote control is connected via the 15-pin sub-D socket and is controlled by means of a "PLC level"15.

Operation with DCU or HPU

- Consider the following manuals for the operation via Pfeiffer Vacuum display and control units:
 - Operating instructions "DCU"
 - Operating instructions "HPU"
- Connect the display and control unit to the plug "RS485" of the adapter or the connecting cable.
- Switch on the supply voltage with switch S1 on the power supply or on the DCU 110.
- Settings are possible via interface RS-485 by using DCU, HPU or PC.

6.4 Switching on the pump

The pump can be switched on in any pressure range between atmospheric and ultimate pressure.

The pump attains the stated values for throughput rates and ultimate pressure levels only once the operating temperature is reached.

- Before the process starts, allow the pump to warm up with the vacuum flange closed;
 - the warm-up time is dependent on the ambient temperature and is within a range of 15 ... 30 min,
 - the warm-up time can be reduced by using gas ballast, if possible.



CAUTION

Hot surface!

Danger of burns if hot parts are touched. Depending on the operating and ambient conditions, the surface temperature of the pump may rise above 70 °C.

- In this case, use suitable finger guards.

6.5 Switching off

The pump can be switched off in any pressure range.

6.6 The Pfeiffer Vacuum parameter set

General

All function-relevant variables of the pump are anchored in the electronic drive unit as parameters. Each parameter has a three-digit number and a designation. Parameters can be used via Pfeiffer Vacuum display and control units or via RS-485 with the Pfeiffer Vacuum protocol.



Additional parameters in the control unit

For the control of connected external components (e.g. vacuum measurement devices) there are additional parameters fixed in the respective Pfeiffer Vacuum display and control unit.

→ Please consider the respective operating instructions.

Conventions

Parameters are displayed in square brackets as a three-digit number in bold font. The designation may also be stated if necessary.

Example: **[P:312]** Software version

Parameter overview

Annotation

#	Three figure number of the parameter
Display	Display of the parameter name in the LCD * = Representation as a symbol, if necessary
Designation	Short description of the parameter
Functions	Functional description of the parameter
Data type	Type of formatting of the parameter for the use within the Pfeiffer Vacuum protocol
Access method	R: read access; W: write access
Unit	Physical unit of the described characteristic
min / max	Permissible limits for value input
default	Factory settings (partially specific of the pump type)
	Parameter can be stored non volatile in the electronic drive unit and may be re-used after resetting of the mains supply.

The parameters and the hours in operation remain stored in the electronic unit in the event of the system being switched off or of an unintentional power failure.

Control commands

#	Display	Designation	Functions	Data type	Access type	Unit	min	max	default	
002	Standby	Standby	0 = off 1 = on	0	RW		0	1	0	x
009	ErrorAckn	Fault acknowledgment		0	W		1	1		
010	PumpgStatn	Pump	0 = off 1 = on	0	RW		0	1	0	x
019	Cfg DO2	Configuration output DO2	1 = no error 2 = error 5 = target speed is reached 6 = pump on 9 = "0" 10 = "1" 11 = remote priority active	7	RW		0	21	5	x
024	Cfg DO1	Configuration output DO1	Settings see [P:019]	7	RW		0	21	1	x
026	SpdSetMode	Speed setting mode	0 = off 1 = on	7	RW		0	1	0	x
030	ValveMode	Purge gas configuration (if existing)	0 = auto 1 = closed 2 = open	7	RW		0	2	0	x
050	PurgeGas	Purge gas (if existing)	0 = off 1 = on	0	RW		0	1	1	x

#	Display	Designation	Functions	Data type	Access type	Unit	min	max	default	
060	CtrlVialnt	Control via interface	1 = remote 2 = RS-485 4 = PV.can 255 = Unlock the interface selection	7	RW		1	255	1	x
061	IntSelLckd	Interface selection locked	0 = off 1 = on	0	RW		0	1	0	x

Status requests

#	Display	Designation	Functions	Data type	Access type	Unit	min	max	default	
303	Error code	Error code		4	R					
309	ActualSpd	Actual speed (Hz)		1	R	Hz				
310	DrvCurrent	Drive current	Drive current in x.xx A	2	R	A				
311	OpHrsPump	Pump operating hours		1	R	h				x
312	Fw version	Software version of the interface board		4	R					
313	DrvVoltage	Supply voltage	Voltag in x.xx V	2	R	V				
314	OpHrsElec	Electronic drive unit operating hours		1	R	h				x
315	Nominal Spd	Nominal speed (Hz)		1	R	Hz				
316	DrvPower	Drive power	Power in W as a product of voltage [P:313] and current [P:310]	1	R	W				
330	TempPmpBot	Temperature of pump		1	R	°C				
349	ElecName	Device designation		4	R					
354	HW version	Hardware version of the interface board		4	R					
398	ActualSpd	Actual speed (rpm)		1	R	rpm				
399	NominalSpd	Nominal speed (rpm)		1	R	rpm				

Set value settings

#	Display	Designation	Functions	Data type	Access type	Unit	min	max	default	
707	SpdSVal	Setpoint in speed setting mode	Target speed in terms of x.xx % of the nominal speed	2	RW	%	30	170	75	x
717	StdbySVal	Setpoint speed in standby operation	Target speed in terms of x.xx % of the nominal speed	2	RW	%	30	100	66.7	x
721	SlgVlvTime	Setting for purge gas activ		1	RW	s	5	255	60	x
797	RS485Adr	RS-485 interface address		1	RW		1	255	2	x

Configuring the connections

The electronic drive unit is preconfigured in the factory, and the pump is immediately operational with the most necessary functions. The terminals of the electronic drive unit can be configured to suit individual requirements using the parameter set.

Digital outputs

→ Configuration via parameters [P:019] and [P:024].

Option	Description
1 = no error	active with fault-free operation
2 = error	active if an error message is active
5 = target speed reached	active if the target speed is reached
6 = pump on	active if the pumping station is on, the motor is on and there is no error
9 = always 0	GND for the control of an external device
10 = always 1	V+ for the control of an external device
11 = remote priority active	active if remote priority is active

Control via interface

→ Configuration via parameters **[P:060]** and **[P:061]**.

Option [P:060]	Description
1 = remote	Operation via connection " <i>remote</i> "
2 = RS-485	Operation via connection " <i>RS-485</i> "
4 = PV.can	For service purposes only

Option [P:061]	Description
0 = off	Interface selection via [P:060]
1 = on	Interface selection locked

Operation with DCU



Parameter set and Pfeiffer Vacuum display and control unit

Pfeiffer Vacuum display and control units DCU show the basic parameter set by default. Furthermore the DCU contains parameters, which are not positioned in the electronic drive unit.

→ Parameter **[P:794]** = 1 (Display of all available parameters).

#	Display	Designation	Functions	Data type	Access	Unit	min	max	default	
340	Pressure	Pressure value (ActiveLine)		7	R	hPa	1E-10	1E3		
350	Ctr Name	Type of display and control unit		4	R					
351	Ctr Software	Software of display and control unit		4	R					
738	Gaugetype	Type of pressure gauge		4	RW					
794	Param set	Parameterset	0 = basic parameter set 1 = extended parameter set	7	RW		0	1	0	
795	ServiceLin	Insert service line		7	RW				795	

Operation with the Pfeiffer Vacuum parameter set

Factory settings

The electronic drive unit is pre-programmed in the factory. This enables direct, secure operation of the pump without any additional configuration.

Checking the adjustments

→ Before operating with parameters, check set values and control commands for their suitability for the pumping process.

Rotation speed setting mode

The speed can be selected within a range of **30-170 %** of the nominal speed, limited to the pump's specific speed limit. The target speed is adjusted via the setpoint value in speed setting mode **[P:707]**. At a speed higher than the nominal speed (> 100 %), increased wear is possible.

Speed setting mode has priority over standby mode.

→ Parameter **[P:707]** set to the required value in %.

→ Parameter **[P:026]** = 1

→ Parameter query **[P:398]**.



Permissible speed range of the pump

Settings in speed setting mode or standby mode are subject to the permissible speed range of the pump being used. The electronic drive unit automatically adjusts the target speed to the next valid value.

Standby

The speed can be selected within a range of **30-100 %** of the nominal speed. The factory setting for standby is 66.7 % of the nominal speed.

- Parameter **[P:717]** set to the required value in %.
- Parameter **[P:026]** = 0
- Parameter **[P:002]** = 1
- Parameter query **[P:398]**.

Normal mode

- Parameter **[P:002]** = 0
- Parameter **[P:026]** = 0
- Parameter query **[P:398]**.

[P:050] = 1 and [P:030] = 0	[P:050] = 0 or [P:030] = 1 (or =2)
The pump starts in boost mode for a constant time of 15 minutes. It then returns to nominal speed automatically.	The pump starts in boost mode for max. 5 min and is then regulated back to nominal speed depending (based) on the power consumption. If the current threshold is exceeded, it does not automatically result in the speed being increased again; this is only possible again after a pump stop/start.

Table 2: Boost mode

Monitoring the thermal load

If threshold values are overrun, output signals from temperature sensors allow the pump to be brought to a safe condition. Depending on pump type, temperature threshold values for warnings and error messages are saved fixed in the electronic drive unit. For information purposes, various status queries are prepared in the parameter set.

Switching on/off the pump**Switching on**

- Switch on the supply voltage with switch S1 on the power supply.
- Parameter **[P:010]** = 1

Ongoing (and removed) error messages are reset.

Switching off

- Parameter **[P:010]** = 0
- Wait for the complete standstill of the pump.
- Cut off the supply voltage with switch S1 on the power supply.

7 Pfeiffer Vacuum Protocol for "RS-485"

7.1 Telegram frame

The telegram frame of the Pfeiffer Vacuum protocol contains only ASCII code characters [32; 127], the exception being the end character of the message C_R . Basically, a master \square (e.g. a PC) sends a telegram, which is answered by a slave \circ (e.g. electronic drive unit or gauge).

a2	a1	a0	*	0	n2	n1	n0	l1	l0	dn	...	d0	c2	c1	c0	C_R
a2 - a0		Unit address for slave \circ - Individual address of the unit ["001";"255"] - Group address "9xx" for all identical units (no response) - global address "000" for all units on the bus (no response)														
*		Action (see p. 22, chap. 7.2)														
n2 - n0		Pfeiffer Vacuum parameter numbers														
l1 - l0		Data length dn ... d0														
dn - d0		Data in data type concerned (see p. 23, chap. 7.3)														
c2 - c0		Checksum (sum of ASCII values of cells a2 to d0) modulo 256														
C_R		carriage return (ASCII 13)														

7.2 Telegrams

Data request $\square \Rightarrow \circ ?$

a2	a1	a0	0	0	n2	n1	n0	0	2	=	?	c2	c1	c0	C_R
----	----	----	---	---	----	----	----	---	---	---	---	----	----	----	-------

Control command $\square \Rightarrow \circ !$

a2	a1	a0	1	0	n2	n1	n0	l1	l0	dn	...	d0	c2	c1	c0	C_R
----	----	----	---	---	----	----	----	----	----	----	-----	----	----	----	----	-------

Data response / control command understood $\circ \Rightarrow \square \checkmark$

a2	a1	a0	1	0	n2	n1	n0	l1	l0	dn	...	d0	c2	c1	c0	C_R
----	----	----	---	---	----	----	----	----	----	----	-----	----	----	----	----	-------

Error message $\circ \Rightarrow \square *$

a2	a1	a0	1	0	n2	n1	n0	0	6	N	O	_	D	E	F	c2	c1	c0	C_R
										_	R	A	N	G	E				
										_	L	O	G	I	C				

NO_DEF	The parameter n2 - n0 does not exist
_RANGE	Data dn - d0 are outside the permitted range
_LOGIC	Logic access violation

Example 1

Data request

Actual rotation speed (parameter [P:309], device address slave: "123")

$\square \Rightarrow \circ ?$	1	2	3	0	0	3	0	9	0	2	=	?	1	1	2	C_R
ASCII	49	50	51	48	48	51	48	57	48	50	61	63	49	49	50	13

Data response: 633 Hz

Actual rotation speed (parameter [P:309], device address slave: "123")

$\circ \Rightarrow \square \checkmark$	1	2	3	1	0	3	0	9	0	6	0	0	0	6	3	3	0	3	7	C_R
ASCII	49	50	51	49	48	51	48	57	48	54	48	48	48	54	51	51	48	51	55	13

Example 2**Control command**

Switch on pumping station (parameter [P:010], device address slave: "042")

☐⇒○!	0	4	2	1	0	0	1	0	0	6	1	1	1	1	1	1	0	2	0	C _R
ASCII	48	52	50	49	48	48	49	48	48	54	49	49	49	49	49	49	48	50	48	13

Control command understood

Switch on pumping station (parameter [P:010], device address slave: "042")

○⇒☐!	0	4	2	1	0	0	1	0	0	6	1	1	1	1	1	1	0	2	0	C _R
ASCII	48	52	50	49	48	48	49	48	48	54	49	49	49	49	49	49	48	50	48	13

7.3 Applied data types

Data type	Description	Size I1 - I0	Example
0 - boolean_old	Boolean value (false / true)	06	000000 / 111111
1 - u_integer	Positive integer number	06	000000 to 999999
2 - u_real	Positive fixed point number	06	001571 equal to 15.71
4 - string	String	06	TC_400
6 - boolean_new	Boolean value (false / true)	01	0 / 1
7 - u_short_int	Positive integer number	03	000 to 999
10 - u_expo_new	Positive exponential number	06	100023
11 - string	String	16	BrezelBier&Wurst

8 Maintenance

8.1 Precautions



WARNING

Pump parts may be contaminated from pumped media!

Danger of poisoning due to contact with harmful substances.

- Decontaminate the pump before carrying out any maintenance work.
- In the event of contamination, take suitable safety precautions to prevent your health from being harmed by any dangerous substances.

The valves and the diaphragms are wear parts. If the rated ultimate vacuum is no longer achieved, the pump interior, the diaphragms and the valves must be cleaned and the diaphragms and valves must be checked for cracks or other damage.

Depending on individual cases it may be efficient to check and clean the pump heads on a regular basis. In case of normal wear the lifetime of the diaphragms and valves is **15000** operating hours at nominal rotation speed.

- Turn off the vacuum pump, vent to atmospheric pressure and allow to cool.
- Switch off the power supply on the control unit/power supply or disconnect the equipment from the mains supply.
- Only dismantle the pump as far as necessary to carry out maintenance.
- Only clean valves and diaphragms with a dry cloth; do not use alcohol or any other detergents.
- Reassemble pump in reverse order.



NOTICE

Service work should be carried out by a qualified person only!

Pfeiffer Vacuum is not liable for any damage to the pump resulting from work carried out improperly.

- Take advantage of our service training programs; additional information at www.pfeiffer-vacuum.com.
- Please state all the information on the pump rating plate when ordering spare parts.

Checklist for inspection, maintenance and overhaul

Certain maintenance and overhaul work should only be performed by Pfeiffer Vacuum Service (PV). Pfeiffer Vacuum will be released from all warranty and liability claims if the required, below listed, intervals are exceeded or maintenance or overhaul procedures are not performed properly. This also applies if replacement parts other than Pfeiffer Vacuum OEM replacement parts are used.

Activity	daily	as required; at least once every six months	as required; at least after 15000 h	as required; at least every 2 years
Check silencer for contamination		X		
Clean, change valves and diaphragms			X	
Change silencer				X

Depending on the process, the required intervals for inspection and maintenance may be shorter than the guide values specified in the table. Please consult Pfeiffer Vacuum, if necessary.

8.2 Cleaning and replacing diaphragms and valves



NOTICE

Damage to the pump and bad ultimate pressure!

A changed dead centre (TDC) leads in the most unfavorable case to a bearing damage.

→ Check for spacer disk 7.

→ Make sure that the original number is reassembled at the individual membrane head.

Dismantling

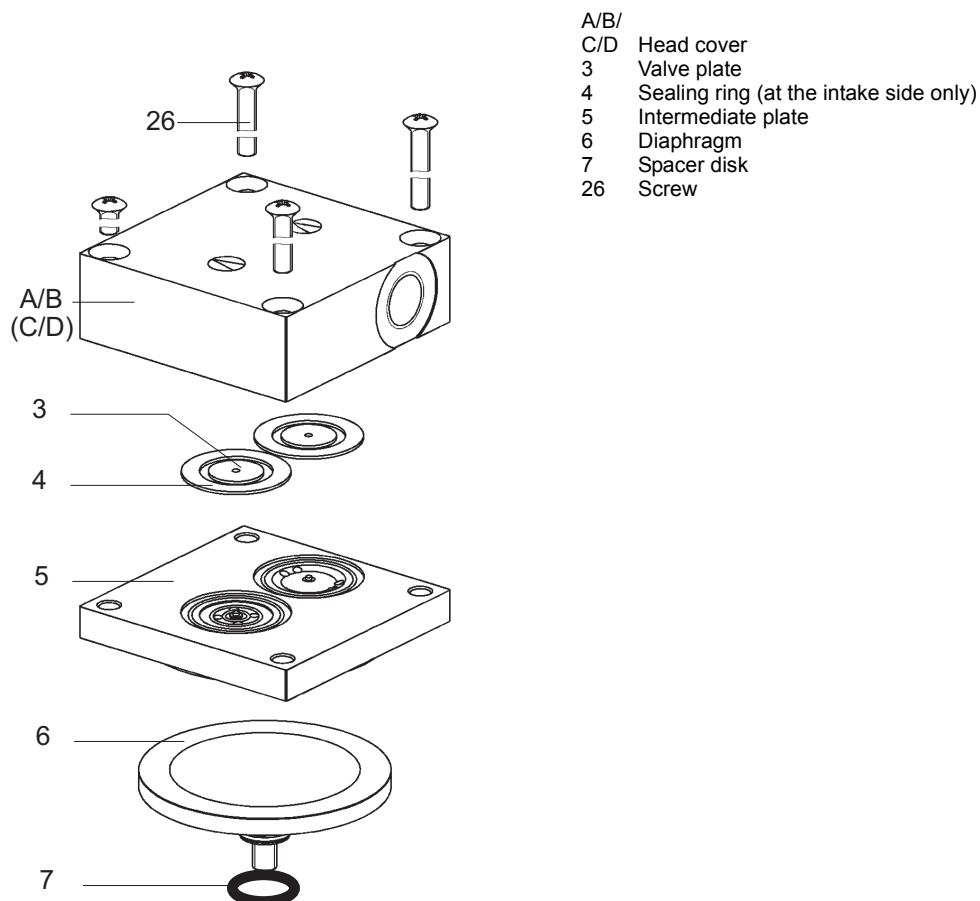

Fig. 6: Replacing diaphragm and valves

- Unscrew the hose connection between the pump stages by loosening the hollow screw with a wrench (size 14).
- Place pump on the side with the diaphragm head face upwards.
- Unscrew screws 26 (4 pieces) from the respective head cover, and remove head cover; be careful with the sealing rings 4 and seal 39.
- Remove intermediate plate 5.
- Remove valves 3 and sealing rings 4 from the intermediate plate.
- Lift the diaphragm 6 slightly on the edge and manually unscrew from the connecting rod (right-hand thread); be careful with spacer disk 7.

Assembling

- **Assembling** is carried out in reverse order.
- Only clean valves and diaphragms with a dry cloth; do not use alcohol or any other detergents.
- Clean valve seats, intermediate plate and head cover using alcohol and check for wear.
- Check bypass bore in the intermediate plate 5 of the intake side.
- Exchange wear parts according to spare parts package.

9 Decommissioning

9.1 Shutting down for longer periods

Follow the following procedure before shutting down the pump for a longer period of time:

Shortly after condensate has formed:

- Let the vacuum pump continue to run for several minutes with the intake port open.
- Should media get into the pump which could corrode the pump materials or form deposits, clean and check the diaphragm heads.

In the long term:

- Carry out the measures described for brief shutdowns.
- Disconnect the pump from the equipment.
- Close the inlet and outlet opening (e.g. with transport caps).
- Store the pump in a cool, dry place; preferably at room temperature (approx. 20°C).
 - For a longer period of storage, seal the pump in a PE bag with drying agents enclosed.

10 Malfunctions

Please note the following instructions should the pump malfunction:



CAUTION

Hot surface!

Danger of burns if hot parts are touched. The surface temperature of the pump may rise above 70 °C in case of malfunction.

- Carry out work on the pump only after it has cooled to a safe temperature.

10.1 Rectifying malfunctions

Problem	Possible causes	Remedy
Pump will not start up	No supply voltage or voltage does not correspond to the motor data	Check the supply voltage
	Pump temperature too low	Heat the pump up to > 5°C
	Thermal protection of the motor has responded	Detect and fix cause of overheating; allow pump to cool off if necessary.
	Diaphragms or valves dirty	Clean the pump (see p. 24, chap. 8)
	Overpressure in the exhaust lead	Check exhaust lead
Pump switches off after a while after being started	Thermal protection of the motor has responded	Detect and fix cause of overheating; allow the motor to cool off if necessary.
	Exhaust pressure too high	Check opening of exhaust line and exhaust accessories
Pump not reaching the end pressure	Condensate in the pump	Operate pump for a longer period of time at atmospheric pressure; if necessary, use the gas ballast valve
	Gas ballast open	Close gas ballast
	Valves or diaphragms dirty or defective	Clean or change valves and diaphragms (see p. 24, chap. 8)
	Leak in the system	Fix leak
Pumping speed of pump too low	Intake line not well-dimensioned	Keep connections as short as possible and see that cross-sections are sufficiently dimensioned
	Exhaust pressure too high	Check opening of exhaust line and exhaust accessories
Unusual noises during operation	Diaphragms or valves defective	Clean or change valves and diaphragms
	Suction chamber dirty	Cleaning the suction chamber
	Silencer loose or missing	Check silencer; replace if necessary
	Valves dirty or defective	Clean or change valves and diaphragms
	Connection rod or motor bearing defective	Contact Pfeiffer Vacuum Service



NOTICE

Service work should be carried out by a qualified person only!

Pfeiffer Vacuum is not liable for any damage to the pump resulting from work carried out improperly.

→ Take advantage of our service training programs; additional information at www.pfeiffer-vacuum.com.

→ Please state all the information on the pump rating plate when ordering spare parts.

10.2 Error codes

Errors can only be acknowledged with voltage "Off/On":

Error code	Problem	Possible causes	Remedy
Err042	Software inconsistency	Checksum error	⇒ Call Pfeiffer Vacuum Service
Err091	Hardware unknown		⇒ Call Pfeiffer Vacuum Service
Err098	Internal communication error between the interface board and drive		⇒ Call Pfeiffer Vacuum Service
Err117	Excess temperature pump	– Insufficient cooling	⇒ Improve cooling ⇒ Check deployment conditions
Err173	Pump overcurrent		
Err174	Pump blocked		

11 Service

Pfeiffer Vacuum offers first-class service!

- Maintenance/repairs on the spot by Pfeiffer Vacuum field service
- Maintenance/repairs in the nearby service center or service point
- Fast replacement with exchange products in mint condition
- Advice on the most cost-efficient and quickest solution

Detailed information and addresses at: www.pfeiffer-vacuum.com (Service).

Maintenance and repairs in the Pfeiffer Vacuum ServiceCenter

The following steps are necessary to ensure a fast, smooth servicing process:

- ➔ Download the forms "Service Request" and "Declaration on Contamination".¹⁾
- ➔ Fill in the "Service Request" form and send it by fax or e-mail to your service address.
- ➔ Include the confirmation on the service request from Pfeiffer Vacuum with your shipment.
- ➔ Fill in the contamination declaration and enclose it in the shipment (required!).
- ➔ Dismantle all accessories.
- ➔ Send the pump in its original packaging if at all possible.

Sending of contaminated pumps or devices

No units will be accepted if they are contaminated with micro-biological, explosive or radioactive substances. "Hazardous substances" are substances and compounds in accordance with the hazardous goods directive (current version). If pumps are contaminated or the declaration on contamination is missing, Pfeiffer Vacuum performs decontamination at the shipper's expense.

- ➔ Neutralise the pump by flushing it with nitrogen or dry air.
- ➔ Close all openings airtight.
- ➔ Seal the pump or unit in suitable protective film.
- ➔ Return the pump/unit only in a suitable and sturdy transport container and send it in while following applicable transport conditions.

Service orders

All service orders are carried out exclusively according to our repair conditions for vacuum units and components.

¹⁾ Forms under www.pfeiffer-vacuum.com

12 Spare parts

Spare parts package/spare parts	Nr.	comprising the following parts
Wearing parts set	PU E22 030 -T	3, 4, 6
Silencer	P 0920 567 E	

13 Accessories

Designation	MVP 010-3 DC
Hose connection DN 6x400 mm with straight fitting G 1/8" and G 1/4"	P 0920 739 E
Hose connection DN 6x1000 mm with straight fitting G 1/8" and G 1/4"	P 0920 817 E
Hose DN 6; (ø 8/6 mm) polyethylene	P 0991 939
Push-in fitting G 1/8" including seal for hose connection (8/6 mm)	P 4131 029
Push-in T-fitting G 1/8"	P 4131 030 E
Mains cable 230 V AC, CEE 7/7 to C13, 3 m	P 4564 309 ZA
Mains cable 115 V AC, NEMA 5-15 to C13, 3 m	P 4564 309 ZE
Mains cable 115 / 230 V without plug, with IEC 320/C13 socket (straight), 3 m	P 4564 309 ZH
Y-Connector M12 to RS-485	P 4723 010
Connection cable MVP-TC-TPS, 3 m	PE 100 013 -T
Screw-in flange DN 16 ISO-KF / G 1/8"	PK 050 108 -T
Foot plate with damper	PK 050 273
HPU 001, Handheld Programming Unit	PM 051 510 -T
USB converter to RS-485 interface	PM 061 207 -T
Interface cable, M12 m straight/M12 m straight, 3 m	PM 061 283 -T
TPS 110, mains pack for wall/standard rail fitting	PM 061 340 -T
TPS 111, mains pack 19" rack module 3HU	PM 061 344 -T
DCU 002, Display Control Unit	PM 061 348 -T
Connection cable with RS-485 interface for TC 110/120 to power supply	PM 061 350 -T
Connection cable for HiPace with TC 110/120	PM 061 543 -T
DCU 110, Display control unit incl. power supply	PM C01 820

Further detailed accessories are contained in the Pfeiffer Vacuum printed or Online Catalogue.

14 Technical data and dimensions

14.1 General

The following harmonised standards are fulfilled:

- IEC 61010-1
- UL 61010-1
- CSA 61010-1

Conversion table: pressure units

	mbar	bar	Pa	hPa	kPa	Torr mm Hg
mbar	1	$1 \cdot 10^{-3}$	100	1	0.1	0.75
bar	1000	1	$1 \cdot 10^5$	1000	100	750
Pa	0.01	$1 \cdot 10^{-5}$	1	0.01	$1 \cdot 10^{-3}$	$7.5 \cdot 10^{-3}$
hPa	1	$1 \cdot 10^{-3}$	100	1	0.1	0.75
kPa	10	0.01	1000	10	1	7.5
Torr mm Hg	1.33	$1.33 \cdot 10^{-3}$	133.32	1.33	0.133	1

$1 \text{ Pa} = 1 \text{ N/m}^2$

Conversion table: gas throughput units

	mbar·l/s	Pa·m ³ /s	sccm	Torr·l/s	atm·cm ³ /s
mbar·l/s	1	0.1	59.2	0.75	0.987
Pa·m ³ /s	10	1	592	7.5	9.87
sccm	$1.69 \cdot 10^{-2}$	$1.69 \cdot 10^{-3}$	1	$1.27 \cdot 10^{-2}$	$1.67 \cdot 10^{-2}$
Torr·l/s	1.33	0.133	78.9	1	1.32
atm·cm ³ /s	1.01	0.101	59.8	0.76	1

14.2 Technical data

Parameter	MVP 010-3 DC
Dimensions (L x W x H)	180x106x100 mm ³
Flange (in)	G 1/8"
Flange (out)	G 1/8" with silencer
Pumping speed, max.	0.6 m ³ /h
Ultimate pressure without gas ballast	≤ 1.0 hPa
Intake pressure max.	1100 hPa
Exhaust pressure, max.	1100 hPa
Rotation speed max.	3000 min ⁻¹
Emission sound pressure level without gas ballast	≤ 50 dB (A)
Ambient temperature	5-40 °C
Protection category	IP20
Supply: Voltage	24 (+/-10%) V DC
Current consumption (max.)	2.5 A
Rated current consumption	1.3 A
Integral leak rate	5 · 10 ⁻⁴ Pa m ³ /s
Weight: with motor	2.0 kg
Cooling method, standard	Air

14.3 Substances in contact with the media

MVP 010-3 DC	Substances in contact with the media
Diaphragm	EPDM
Valve seals	EPDM
Head cover	Aluminium
Hose connection	PVC
Elbow union	Aluminium
Straight union at intake hose	CuZn nickel-plated
Exhaust, silencer	Polyamide

14.4 Dimensions

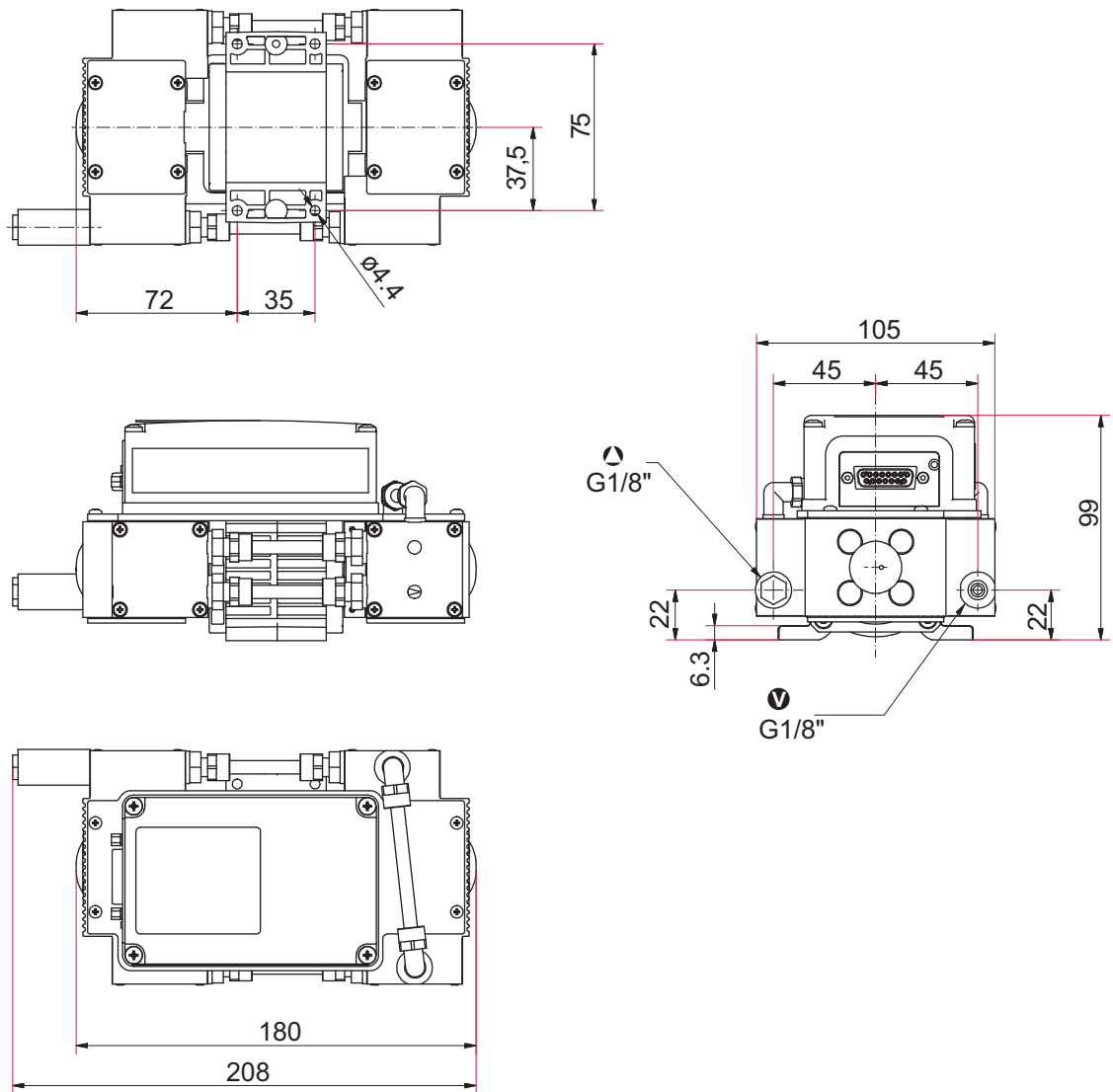

Fig. 7: MVP 010-3 DC



Declaration of conformity

We hereby declare that the product cited below satisfies all relevant provisions according to the following **EC directives**:

- **Machinery 2006/42/EC (Annex II, no. 1 A)**
- **Electromagnetic Compatibility 2014/30/EU**
- **Restriction of the use of certain Hazardous Substances 2011/65/EU**

The agent responsible for compiling the technical documentation is Mr. Sebastian Oberbeck, Pfeiffer Vacuum GmbH, Berliner Straße 43, 35614 Asslar.

MVP 010-3 DC

Harmonised standards and national standards and specifications which have been applied:

DIN EN ISO 12100 : 2010	DIN EN 61326-1 : 2013-07	DIN EN 61000-3-2 : 2013
DIN EN 1012-2 : 2011-12	DIN EN 55011 : 2009 + A1: 2010	DIN EN 61000-3-3 : 2013
DIN EN 61010-1 : 2010		

Signature:

Pfeiffer Vacuum GmbH
Berliner Straße 43
35614 Asslar
Germany

(Dr. Ulrich von Hülsen)
Managing Director

Asslar, 2018-12-14

VACUUM SOLUTIONS FROM A SINGLE SOURCE

Pfeiffer Vacuum stands for innovative and custom vacuum solutions worldwide, technological perfection, competent advice and reliable service.

COMPLETE RANGE OF PRODUCTS

From a single component to complex systems:

We are the only supplier of vacuum technology that provides a complete product portfolio.

COMPETENCE IN THEORY AND PRACTICE

Benefit from our know-how and our portfolio of training opportunities!

We support you with your plant layout and provide first-class on-site service worldwide.

Are you looking for a
perfect vacuum solution?
Please contact us:

Chemtech Scientific provides access to this content as a courtesy.
We do not own the content contained in this document.
All rights and credit go directly to its rightful owners.
www.chemtechsci.com
Call us at: 484-424-9415

