



OPERATING INSTRUCTIONS

EN

Translation of the Original

MVP 030-3 DC

Diaphragm Pump

Chemtech Scientific provides access to this content as a courtesy.
We do not own the content contained in this document.
All rights and credit go directly to its rightful owners.
www.chemtechsci.com
Call us at: 484-424-9415



Dear Customer,

Thank you for choosing a Pfeiffer Vacuum product. Your new diaphragm pump is designed to support you with its performance, perfect operation and without impacting your individual application. The name Pfeiffer Vacuum stands for high-quality vacuum technology, a comprehensive and complete range of top-quality products and first-class service. From this extensive, practical experience we have gained a large volume of information that can contribute to efficient deployment and to your personal safety.

In the knowledge that our product must avoid consuming work output, we trust that our product can offer you a solution that supports you in the effective and trouble-free implementation of your individual application.

Please read these operating instructions before putting your product into operation for the first time. If you have any questions or suggestions, please feel free to contact info@pfeiffer-vacuum.de.

Further operating instructions from Pfeiffer Vacuum can be found in the [Download Center](#) on our website.

Disclaimer of liability

These operating instructions describe all models and variants of your product. Note that your product may not be equipped with all features described in this document. Pfeiffer Vacuum constantly adapts its products to the latest state of the art without prior notice. Please take into account that online operating instructions can deviate from the printed operating instructions supplied with your product.

Furthermore, Pfeiffer Vacuum assumes no responsibility or liability for damage resulting from the use of the product that contradicts its proper use or is explicitly defined as foreseeable misuse.

Copyright

This document is the intellectual property of Pfeiffer Vacuum and all contents of this document are protected by copyright. They may not be copied, altered, reproduced or published without the prior written permission of Pfeiffer Vacuum.

We reserve the right to make changes to the technical data and information in this document.

Table of contents

1	About this manual	7
1.1	Validity	7
	1.1.1 Applicable documents	7
	1.1.2 Variants	7
1.2	Target group	7
1.3	Conventions	7
	1.3.1 Instructions in the text	7
	1.3.2 Pictographs	8
	1.3.3 Stickers on the product	8
	1.3.4 Abbreviations	9
2	Safety	10
2.1	General safety information	10
2.2	Safety instructions	10
2.3	Safety precautions	12
2.4	Limits of use of the product	13
2.5	Proper use	13
2.6	Foreseeable improper use	13
2.7	Personnel qualification	14
	2.7.1 Ensuring personnel qualification	14
	2.7.2 Personnel qualification for maintenance and repair	15
	2.7.3 Advanced training with Pfeiffer Vacuum	15
3	Product description	16
3.1	Function	16
3.2	Identifying the product	16
3.3	Shipment	16
4	Transportation and Storage	17
4.1	Transporting the vacuum pump	17
4.2	Storing the vacuum pump	17
5	Installation	18
5.1	Installing the vacuum pump	18
5.2	Connecting the vacuum side	18
5.3	Connecting the exhaust side	19
6	Interfaces	20
6.1	Voltage supply	22
6.2	Inputs	22
6.3	Outputs	23
6.4	Interface RS-485	23
6.5	Cross-linked via the RS-485 connection	24
6.6	Connection options via interface RS-485	25
6.7	Pfeiffer Vacuum protocol for RS-485 interface	25
	6.7.1 Telegram frame	25
	6.7.2 Telegram description	26
	6.7.3 Telegram example 1	26
	6.7.4 Telegram example 2	26
	6.7.5 Data types	27
7	Parameter set	28
7.1	General	28
7.2	Control commands	28
7.3	Status requests	29
7.4	Reference value inputs	30
7.5	Additional parameter for the DCU	30

8	Operation	31
8.1	Putting the vacuum pump into operation	31
8.2	Switching on the vacuum pump	31
8.3	Configuring the connections with the Pfeiffer Vacuum parameter set	32
8.3.1	Configuring the digital outputs	32
8.3.2	Selecting the interfaces	32
8.4	Operating modes	32
8.4.1	Speed actuator operation	33
8.4.2	Standby mode	33
8.4.3	Normal operation	34
8.5	Pumping condensable vapors	34
8.6	Operation monitoring	35
8.6.1	Operating mode display via LED	35
8.6.2	Temperature monitoring	35
8.7	Switching off the vacuum pump	35
9	Maintenance	36
9.1	Maintenance instructions	36
9.2	Checklist for inspection and maintenance	37
9.3	Dismantling / installing the handle	37
9.4	Change the diaphragms and valves	38
9.4.1	Dismantle the pump head and valves	38
9.4.2	Dismantling the diaphragms	39
9.4.3	Installing the diaphragm	41
9.4.4	Installing the pump head and valves	41
9.5	Checking the ultimate pressure	42
10	Decommissioning	43
11	Recycling and disposal	44
11.1	General disposal information	44
11.2	Dispose of diaphragm pumps	44
12	Malfunctions	45
12.1	General	45
12.2	Error codes	46
12.3	Warning and error messages when operating with DCU	46
13	Service solutions by Pfeiffer Vacuum	48
14	Spare parts packs	50
15	Accessories	51
15.1	Accessory information	51
15.2	Ordering accessories	51
16	Technical data and dimensions	52
16.1	General	52
16.2	Technical data	52
16.3	Substances in contact with the media	53
16.4	Dimensions	53
	Declaration of conformity	54

List of tables

Tbl. 1:	Stickers on the product	8
Tbl. 2:	Abbreviations used in this document	9
Tbl. 3:	Limits of use of the product	13
Tbl. 4:	Intake temperature limits of use	13
Tbl. 5:	Connection plug arrangement Simple Pump Interface D-Sub-socket, 15-pin	20
Tbl. 6:	Features of the RS-485 interface	23
Tbl. 7:	Explanation and meaning of the parameters	28
Tbl. 8:	Parameter set Control commands	29
Tbl. 9:	Parameter set Status requests	29
Tbl. 10:	Parameter set Reference value inputs	30
Tbl. 11:	Parameter for DCU functions	30
Tbl. 12:	Factory setting of the electronic drive unit for diaphragm pumps when delivered	31
Tbl. 13:	Configure parameters [P:019] and [P:024]	32
Tbl. 14:	Parameters [P:060] and [P:061]	32
Tbl. 15:	Behavior and meaning of the LED of the electronic drive unit	35
Tbl. 16:	Typical service life with normal use	36
Tbl. 17:	Maintenance intervals	37
Tbl. 18:	Troubleshooting on diaphragm pumps	46
Tbl. 19:	Error messages for vacuum pump	46
Tbl. 20:	Warning messages for vacuum pump	46
Tbl. 21:	Warning and error messages when using a DCU	47
Tbl. 22:	Spare parts packs	50
Tbl. 23:	Accessories	51
Tbl. 24:	Conversion table: Pressure units	52
Tbl. 25:	Conversion table: Units for gas throughput	52
Tbl. 26:	Technical data, MVP 030-3 DC	53
Tbl. 27:	Materials that make contact with the process media	53

List of figures

Fig. 1:	Position of the stickers on the product	8
Fig. 2:	Diaphragm pump design	16
Fig. 3:	Minimum distances	18
Fig. 4:	Pin assignment of the D-Sub socket, 15-pin	20
Fig. 5:	Connection example: MVP 030-3 DC – DCU/TPS	21
Fig. 6:	Connection example: MVP 030-3 DC – HiPace/DCU/TPS	22
Fig. 7:	Networking via the RS-485 interface	24
Fig. 8:	Connection options via interface RS-485	25
Fig. 9:	Mounting the flushing gas nozzle	34
Fig. 10:	Handle	38
Fig. 11:	Pump head and valves	39
Fig. 12:	Replacing the diaphragms	40
Fig. 13:	Correct mounting orientation of the valves in the head cover	41
Fig. 14:	Spare parts	50
Fig. 15:	Dimensions MVP 030-3 DC	53

1 About this manual



IMPORTANT

Read carefully before use.
Keep the manual for future consultation.

1.1 Validity

This operating instructions is a customer document of Pfeiffer Vacuum. The operating instructions describe the functions of the named product and provide the most important information for the safe use of the device. The description is written in accordance with the valid directives. The information in this operating instructions refers to the product's current development status. The document shall remain valid provided that the customer does not make any changes to the product.

1.1.1 Applicable documents

Designation	Document
Declaration of conformity	A component of these operating instructions

1.1.2 Variants

These instructions apply to diaphragm pumps of the DC series:

- MVP 030-3 DC as standard version
- MVP 030-3 DC in the version for the integration in a pumping station (without handle and rubber feet)

1.2 Target group

These operating instructions are aimed at all persons performing the following activities on the product:

- Transportation
- Setup (Installation)
- Usage and operation
- Decommissioning
- Maintenance and cleaning
- Storage or disposal

The work described in this document is only permitted to be performed by persons with the appropriate technical qualifications (expert personnel) or who have received the relevant training from Pfeiffer Vacuum.

1.3 Conventions

1.3.1 Instructions in the text

Usage instructions in the document follow a general structure that is complete in itself. The required action is indicated by an individual step or multi-part action steps.

Individual action step

A horizontal, solid triangle indicates the only step in an action.

- ▶ This is an individual action step.

Sequence of multi-part action steps

The numerical list indicates an action with multiple necessary steps.

1. Step 1
2. Step 2
3. ...

1.3.2 Pictographs

Pictographs used in the document indicate useful information.



Note



Tip

1.3.3 Stickers on the product

This section describes all the stickers on the product along with their meaning.

	<p>Rating plate Rating plate of the diaphragm pump</p>
	<p>Warning of hot surfaces The sticker warns of hot surfaces during operation or immediately after switching off the vacuum pump.</p>
	<p>General warning signs The sticker provides a general warning of possible dangers.</p>
	<p>Closure seal The diaphragm heads are sealed at the factory. Damaging or removing a closure seal results in loss of the warranty.</p>

Tbl. 1: Stickers on the product

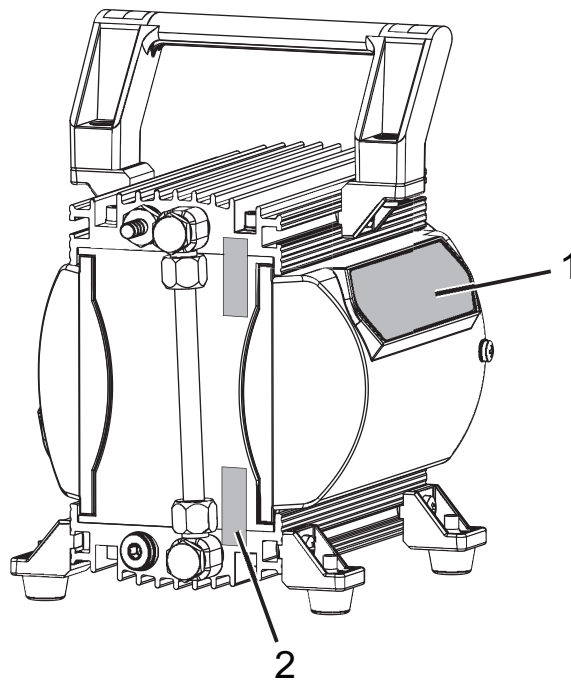

Fig. 1: Position of the stickers on the product

- 1 Rating plate of the diaphragm pump
Incl. the 2 warning signs
- 2 Warranty seal (2×)

1.3.4 Abbreviations

Abbreviation	Meaning in this document
DC	Direct current
DCU	Display and Control Unit from Pfeiffer Vacuum.
DN	Nominal diameter (diamètre nominal)
f	Rotation speed value of a vacuum pump (frequency, in rpm or Hz)
HPU	Handheld Programming Unit, aid for controlling and monitoring pump parameters
LED	Light emitting diode
MVP	Diaphragm vacuum pump
MSL	Mean sea level
[P:xxx]	Electronic drive unit control parameters. Printed in bold as a three-digit number in square brackets. Frequently displayed in conjunction with a short description. Example: [P:312] software version
PE	Earthed conductor (protective earth)
PWM	Pulse width modulation (Type of modulation where one technical variable (e.g. electrical voltage) changes between two values.)
T	Temperature (in °C), property abbreviation of the vacuum pump
TC	Turbopump electronic drive unit (turbo controller)
TPS	Voltage supply (turbo power supply)

Tbl. 2: Abbreviations used in this document

2 Safety

2.1 General safety information

The following 4 risk levels and 1 information level are taken into account in this document.

⚠ DANGER	
<p>Immediately pending danger Indicates an immediately pending danger that will result in death or serious injury if not observed.</p> <ul style="list-style-type: none"> ▶ Instructions to avoid the danger situation 	
⚠ WARNING	
<p>Potential pending danger Indicates a pending danger that could result in death or serious injury if not observed.</p> <ul style="list-style-type: none"> ▶ Instructions to avoid the danger situation 	
⚠ CAUTION	
<p>Potential pending danger Indicates a pending danger that could result in minor injuries if not observed.</p> <ul style="list-style-type: none"> ▶ Instructions to avoid the danger situation 	
NOTICE	
<p>Danger of damage to property Is used to highlight actions that are not associated with personal injury.</p> <ul style="list-style-type: none"> ▶ Instructions to avoid damage to property 	
<div style="border: 1px solid black; padding: 5px; display: inline-block;">  </div>	Notes, tips or examples indicate important information about the product or about this document.

2.2 Safety instructions

All safety instructions in this document are based on the results of the risk assessment carried out in accordance with Machinery Directive 2006/42/EC Annex I and EN ISO 12100 Section 5. As far as applicable, all unit life cycle phases have been considered.

Risks during transport

⚠ WARNING
<p>Danger of serious injury due to falling objects Due to falling objects there is a risk of injuries to limbs through to broken bones.</p> <ul style="list-style-type: none"> ▶ Take particular care and pay special attention when transporting products manually. ▶ Do not stack the products. ▶ Wear protective equipment, e.g. safety shoes.

Risks during installation

⚠ DANGER
<p>Danger to life from electric shock When establishing the voltages that exceed the specified safety extra-low voltage (according to IEC 60449 and VDE 0100), the insulating measures will be destroyed. There is a danger to life from electric shock at the communication interfaces.</p> <ul style="list-style-type: none"> ▶ Connect only suitable devices to the bus system.

⚠ CAUTION**Danger of injury from bursting as a result of high pressure in the exhaust line**

Faulty or inadequate exhaust pipes lead to dangerous situations, e.g. increased exhaust pressure. There is a danger of bursting. Injuries caused by flying fragments, the escaping of high pressure, and damage to the unit cannot be excluded.

- ▶ Route the exhaust line without shut-off units.
- ▶ Observe the permissible pressures and pressure differentials for the product.
- ▶ Check the function of the exhaust line on a regular basis.

Risks during operation**⚠ WARNING****Danger of poisoning due to toxic process media escaping from the exhaust pipe**

During operation with no exhaust line, the vacuum pump allows exhaust gases and vapors to escape freely into the air. There is a risk of injury and fatality due to poisoning in processes with toxic process media.

- ▶ Observe the pertinent regulations for handling toxic process media.
- ▶ Safely purge toxic process media via an exhaust line.
- ▶ Use appropriate filter equipment to separate toxic process media.

⚠ WARNING**Risk of explosion from reactive, explosive or other hazardous gas / air mixtures.**

Uncontrolled inlet of gas at the flushing gas nozzle leads to sparks generated mechanically following diaphragm rupture, hot surfaces or to explosive gas / air mixtures in the vacuum system caused by static electricity.

- ▶ If necessary, use inert gas for supplying the flushing gas in order to avoid a potential ignition.

⚠ CAUTION**Danger of burns on hot surfaces**

Depending on the operating and ambient conditions, the surface temperature of the vacuum pump can increase to above 70 °C.

- ▶ Provide suitable touch protection.

⚠ CAUTION**Risk of poisoning due to toxic process gases escaping**

For intake pressures > 500 hPa, process gas may escape from the flushing gas nozzle.

- ▶ If necessary, use an extraction line.

Risks during maintenance, decommissioning and in event of malfunctions**⚠ WARNING****Health hazard through poisoning from toxic contaminated components or devices**

Toxic process media result in contamination of devices or parts of them. During maintenance work, there is a risk to health from contact with these poisonous substances. Illegal disposal of toxic substances causes environmental damage.

- ▶ Take suitable safety precautions and prevent health hazards or environmental pollution by toxic process media.
- ▶ Decontaminate affected parts before carrying out maintenance work.
- ▶ Wear protective equipment.

⚠ CAUTION

Danger of injury from moving parts

After a power failure or a standstill as a result of overheating, the motor restarts automatically. There is a risk of injury to fingers and hands if they enter the operating range of rotating parts.

- ▶ Safely disconnect motor from the mains.
- ▶ Secure the motor against reactivation.
- ▶ Dismantle the vacuum pump for inspection, away from the system if necessary.

⚠ CAUTION

Danger of burns on hot surfaces

In the event of a fault, the surface temperature of the vacuum pump can increase to above 105 °C.

- ▶ Allow the vacuum pump to cool down before carrying out any work.
- ▶ Wear personal protective equipment if necessary.

Risks during disposal

⚠ WARNING

Health hazard through poisoning from toxic contaminated components or devices

Toxic process media result in contamination of devices or parts of them. During maintenance work, there is a risk to health from contact with these poisonous substances. Illegal disposal of toxic substances causes environmental damage.

- ▶ Take suitable safety precautions and prevent health hazards or environmental pollution by toxic process media.
- ▶ Decontaminate affected parts before carrying out maintenance work.
- ▶ Wear protective equipment.

2.3 Safety precautions

⚠ DANGER

Danger to life from electric shock

Power supply packs that are not specified or are not approved will lead to severe injury to death.

- ▶ Make sure that the power supply pack meets the requirements for double isolation between mains input voltage and output voltage, in accordance with IEC 61010-1 IEC 60950-1 and IEC 62368-1.
- ▶ Make sure that the power supply pack meets the requirements in accordance with IEC 61010-1 IEC 60950-1 and IEC 62368-1.
- ▶ Where possible, use original power supply packs or only power supply packs that correspond with the applicable safety regulations.

i

Duty to provide information on potential dangers

The product holder or user is obliged to make all operating personnel aware of dangers posed by this product.

Every person who is involved in the installation, operation or maintenance of the product must read, understand and adhere to the safety-related parts of this document.

i

Infringement of conformity due to modifications to the product

The Declaration of Conformity from the manufacturer is no longer valid if the operator changes the original product or installs additional equipment.

- Following the installation into a system, the operator is required to check and re-evaluate the conformity of the overall system in the context of the relevant European Directives, before commissioning that system.

General safety precautions

- ▶ Prevent process gases and their reaction and ancillary products that are harmful to health and the environmental from escaping, or dispose of these according to the applicable regulations.
- ▶ Avoid contact with process gases that are harmful to health and if required, wear personal protective clothing.
- ▶ Check the media compatibility of parts carrying media.
- ▶ Observe all applicable safety and accident prevention regulations.
- ▶ Check that all safety measures are observed at regular intervals.
- ▶ Do not expose body parts to the vacuum.
- ▶ Never disconnect plug connections during operation.
- ▶ Never fill or operate the unit with cleaning agents or cleaning agent residues.
- ▶ Do not carry out your own conversions or modifications on the unit.
- ▶ Observe the unit protection degree prior to installation or operation in other environments.
- ▶ Provide suitable touch protection, if the surface temperature exceeds 70°C.
- ▶ Keep lines and cables away from hot surfaces.
- ▶ Before returning the vacuum pump, observe the notes in the chapter Service solutions.

2.4 Limits of use of the product

Installation location	Interiors, protected against the accumulation of dust and weather influences, in a non-explosive, dry environment
Protection degree IEC 60529	IP 20
Protection degree UL 50E	NEMA type 1
Installation altitude	max. 2000 m above sea level ¹⁾
Ambient temperature	+10 °C to +40 °C
Relative air humidity	80% at T ≤ 31 °C, to max. 50% at T ≤ 40 °C
Degree of contamination	2

Tbl. 3: Limits of use of the product

Operations condition, status	Intake pressure	Permissible intake temperature of medium to be pumped
Continuous operation	> 100 hPa (high gas load)	+10 °C to +40 °C
Continuous operation	< 100 hPa (low gas load)	0 °C to +60 °C
short-term (< 5 minutes)	< 100 hPa (low gas load)	-10 °C to +80 °C

Tbl. 4: Intake temperature limits of use

2.5 Proper use

- ▶ Use the vacuum pump for vacuum generation only.
- ▶ Adhere to the installation, commissioning, operating, and maintenance instructions.
- ▶ Do not use any accessory parts other than those recommended by Pfeiffer Vacuum.

2.6 Foreseeable improper use

Improper use of the product invalidates all warranty and liability claims. Any use that is counter to the purpose of the product, whether intentional or unintentional, is regarded as improper use; in particular:

- Pumping of corrosive media
- Pumping of explosive media
- Pumping radioactive or volatile media
- Pumping of gases that contain impurities such as particles, dust, or condensate
- Pumping of fluids

1) at an installation location higher than 1000 meters above sea level, there is a risk of insufficient cooling. If necessary, take measures according to Directive DIN EN 61010.

- Pumping FPM-solubilizing media
- Pumping vapors from combustible liquids
- Pumping pressurized media (> atmospheric pressure)
- Pumping media that can condense or cause adhering deposits to form in the suction chamber
- Use of the vacuum pump outside the specified area of application
- Using the vacuum pump below ground
- Using the vacuum pump to generate pressure
- Using the vacuum pump in systems in which sporadic loads and vibrations or periodic forces act on the unit
- Using the vacuum pump in strong electrical, magnetic, or electromagnetic fields
- Connection to vacuum pumps or equipment which are not suitable for this purpose according to their operating instructions
- Connection to devices with exposed live parts
- Connecting to sockets without earthing contact
- Using pipes to lift the vacuum pump
- Use of accessories or spare parts that are not listed in these instructions
- Using the vacuum pump as a climbing aid
- Using the connection lines between the diaphragm heads as carrying handles
- Using the pump in ambient conditions that do not meet the specified IP protection degree limits

2.7 Personnel qualification

The work described in this document may only be carried out by persons who have appropriate professional qualifications and the necessary experience or who have completed the necessary training as provided by Pfeiffer Vacuum.

Training people

1. Train the technical personnel on the product.
2. Only let personnel to be trained work with and on the product when under the supervision of trained personnel.
3. Only allow trained technical personnel to work with the product.
4. Before starting work, make sure that the commissioned personnel have read and understood these operating instructions and all applicable documents, in particular the safety, maintenance and repair information.

2.7.1 Ensuring personnel qualification

Specialist for mechanical work

Only a trained specialist may carry out mechanical work. Within the meaning of this document, specialists are people responsible for construction, mechanical installation, troubleshooting and maintenance of the product, and who have the following qualifications:

- Qualification in the mechanical field in accordance with nationally applicable regulations
- Knowledge of this documentation

Specialist for electrotechnical work

Only a trained electrician may carry out electrical engineering work. Within the meaning of this document, electricians are people responsible for electrical installation, commissioning, troubleshooting, and maintenance of the product, and who have the following qualifications:

- Qualification in the electrical engineering field in accordance with nationally applicable regulations
- Knowledge of this documentation

In addition, these individuals must be familiar with applicable safety regulations and laws, as well as the other standards, guidelines, and laws referred to in this documentation. The above individuals must have an explicitly granted operational authorization to commission, program, configure, mark, and earth devices, systems, and circuits in accordance with safety technology standards.

Trained individuals

Only adequately trained individuals may carry out all works in other transport, storage, operation and disposal fields. Such training must ensure that individuals are capable of carrying out the required activities and work steps safely and properly.

2.7.2 Personnel qualification for maintenance and repair



Advanced training courses

Pfeiffer Vacuum offers advanced training courses to maintenance levels 2 and 3.

Adequately trained individuals are:

- **Maintenance level 1**
 - Customer (trained specialist)
- **Maintenance level 2**
 - Customer with technical education
 - Pfeiffer Vacuum service technician
- **Maintenance level 3**
 - Customer with Pfeiffer Vacuum service training
 - Pfeiffer Vacuum service technician

2.7.3 Advanced training with Pfeiffer Vacuum

For optimal and trouble-free use of this product, Pfeiffer Vacuum offers a comprehensive range of courses and technical trainings.

For more information, please contact [Pfeiffer Vacuum technical training](#).

3 Product description

3.1 Function

The diaphragm pump of the MVP 030-3 DC series is a dry compressing vacuum pump with 3 pumping stages. The vacuum pump is a positive displacement pump with a periodic change in suction chamber size, produced by the movement of the diaphragm. The gas flow causes the valves to open and close automatically. The pump units are directly connected to the drive motor.

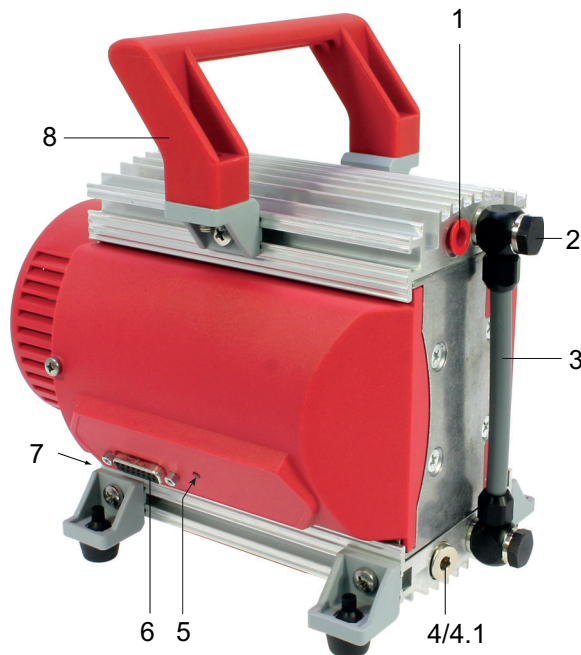

Fig. 2: Diaphragm pump design

- | | | | |
|-----|--------------------------------|---|-----------------------|
| 1 | Vacuum connection, thread 1/8" | 5 | LED |
| 2 | Banjo bolt | 6 | Connecting socket |
| 3 | Interhead connection | 7 | Exhaust with silencer |
| 4 | Locking screw | 8 | Handle |
| 4.1 | Flushing gas nozzle (optional) | | |

3.2 Identifying the product

- ▶ To ensure clear identification of the product when communicating with Pfeiffer Vacuum, always keep all of the information on the rating plate to hand.
- ▶ Learn about certifications through test seals on the product or at www.certipedia.com with company ID no. 000021320.

3.3 Shipment

- Vacuum pump with drive
- Silencer
- Operating instructions
- Blind plug on the vacuum connection

4 Transportation and Storage

4.1 Transporting the vacuum pump

WARNING

Danger of serious injury due to falling objects

Due to falling objects there is a risk of injuries to limbs through to broken bones.

- ▶ Take particular care and pay special attention when transporting products manually.
- ▶ Do not stack the products.
- ▶ Wear protective equipment, e.g. safety shoes.



Packing

We recommend keeping the transport packaging and original protective cover.

General information regarding safe transport

1. Observe the weight specified on packaging.
2. Use a transport aid if necessary (trolley, lift truck).
3. Transport the product in its original packaging.
4. Always place the product on an adequately sized, level surface.

Transporting the vacuum pump without its packaging

1. Unpack the vacuum pump.
2. To protect the inside of the pump, leave both protective caps on the connections during transport.
3. For lifting, use the handle provided for this purpose, located on the top of the pump.
4. Lift the vacuum pump out of the transport packaging.
5. Make sure that no forces are acting on the piping system.
6. Always place the vacuum pump on an adequately sized, level surface.

4.2 Storing the vacuum pump



Packing

We recommend storing the product in its original packaging.

Procedure

1. Seal the vacuum connection with the blind plug.
2. Store the vacuum pump only in dry, dust-free rooms, within the specified ambient conditions.
3. In rooms with humid or aggressive atmospheres: Hermetically seal the vacuum pump together with a drying agent in a plastic bag.

5 Installation

5.1 Installing the vacuum pump

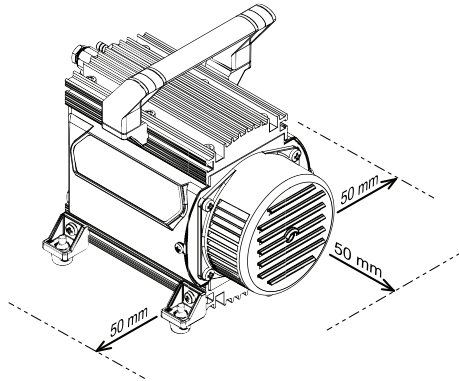

Fig. 3: Minimum distances

Procedure

1. Place the vacuum pump on a flat, horizontal surface.
2. For stationary installation, screw the vacuum pump directly to the base if necessary.
 - For this purpose, dismantle the rubber feet.
3. When installing the pump in a closed housing, ensure adequate air circulation.
 - The vacuum pump does not have a fan.
4. Make sure that minimum distances to adjacent components, e.g., walls, housings, etc., are observed.
5. Keep the specifications on the motor rating plate visible and freely accessible.

5.2 Connecting the vacuum side

NOTICE

Property damage from contaminated gases

Pumping down gases that contain impurities (condensate, particles) damages the vacuum pump.

- ▶ Use suitable filters or separators from the Pfeiffer Vacuum range of accessories, to protect the vacuum pump.



Installation and operation of accessories

Pfeiffer Vacuum offers a series of special, compatible accessories for its diaphragm pumps.

- Information and ordering options for approved [accessories](#) can be found online.
- Described accessories are not included in the shipment.



Preventing throttling losses

Using the shortest possible vacuum connection lines with large nominal diameter prevents pressure losses.



Condensate separator

Pfeiffer Vacuum recommends the installation of a condensate separator in case vapors are formed from moisture during evacuation.

Procedure

1. Remove the blind plug from the vacuum connection.
2. Establish the shortest possible connection between vacuum pump and vacuum chamber.
3. Choose a minimum vacuum line diameter equal to the nominal diameter of the vacuum connection.

4. Depending on the pump type, use PVC or metallic hoses with flange connections from the [Pfeiffer Vacuum component shop](#).
5. Connect the vacuum pump to the vacuum system using the vacuum connection.

5.3 Connecting the exhaust side

WARNING

Danger to life from poisoning where toxic process gases leak with no exhaust line

During normal operation, the vacuum pump expels exhaust gases and vapors freely into the air. In processes involving toxic media, there is a risk of injury and danger to life due to poisoning.

- ▶ Observe the relevant regulations for handling toxic substances.
- ▶ Safely purge toxic process gases via an exhaust line.

CAUTION

Danger of injury from bursting as a result of high pressure in the exhaust line

Faulty or inadequate exhaust pipes lead to dangerous situations, e.g. increased exhaust pressure. There is a danger of bursting. Injuries caused by flying fragments, the escaping of high pressure, and damage to the unit cannot be excluded.

- ▶ Route the exhaust line without shut-off units.
- ▶ Observe the permissible pressures and pressure differentials for the product.
- ▶ Check the function of the exhaust line on a regular basis.



Condensate separator

Pfeiffer Vacuum recommends installing a condensate separator, with condensate drain at the lowest point of the exhaust line.

Procedure

1. Check the installed silencer for free passage.
2. Choose a minimum exhaust line diameter equal to the nominal diameter of the connection flange.
3. Depending on the pump type, use PVC or metallic hoses with flange connections from the [Pfeiffer Vacuum component shop](#).
4. Option: In case of higher gas throughputs, mount an exhaust line.
5. Route the piping downwards from the vacuum pump, to prevent condensate return.
6. Support or suspend the piping to the vacuum pump so that no piping system forces act on the vacuum pump.

6 Interfaces

NOTICE

Property damage on the electronics

Separating all plug-and-socket connections within the bus system with voltage supply switched on may lead to the destruction of electronic components.

- ▶ Always disconnect the voltage supply before removing the connecting plug.
- ▶ After switching off the power supply pack, wait until the residual load has dispersed completely before disconnecting the plug-and-socket connection.

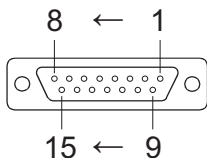

Fig. 4: Pin assignment of the D-Sub socket, 15-pin

Pin	Function	Description, factory setting
1	+24 VDC input	Voltage supply for drive and interface
2	DI access request	V+: Control via DIs, --> GND/open: Control unlocked
3	DI1	V+: Rotation speed setting mode, --> GND/open: no rotation speed setting mode
4	n.c.	
5	DI pumping station	V+: Vacuum pump on, --> GND/open: Vacuum pump off
6	DI standby	V+: standby, --> GND/open: no standby
7	V+	24 V output
8	DO1	GND: Error, V+: no error
9	DO2	GND: Vacuum pump off, V+: Vacuum pump on
10	n.c.	
11	n.c.	
12	n.c.	
13	RS-485	D+
14	RS-485	D-
15	Ground (GND)	Ground connection of the voltage supply; reference ground for all digital inputs and outputs

Tbl. 5: Connection plug arrangement Simple Pump Interface D-Sub-socket, 15-pin

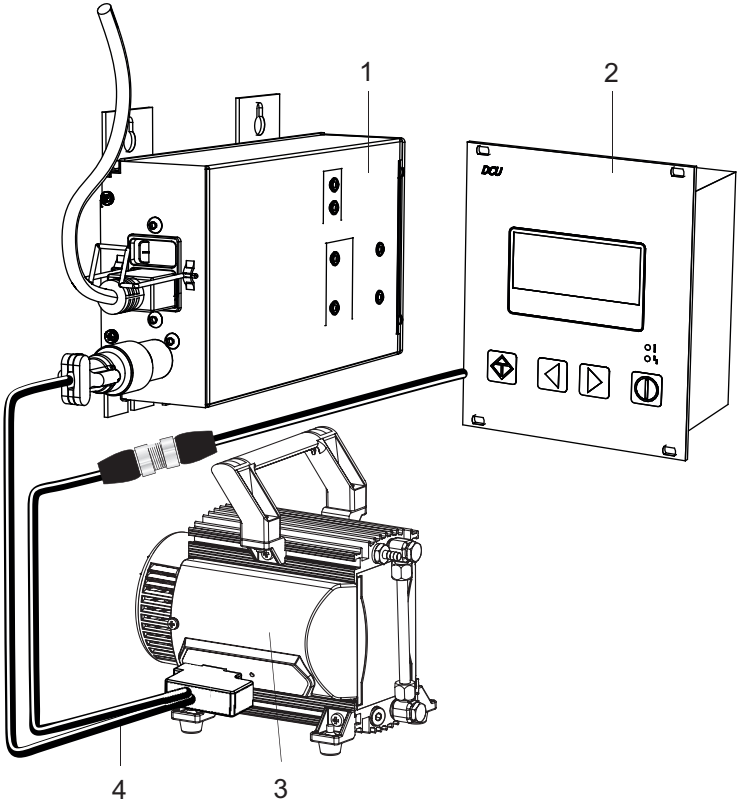

Fig. 5: Connection example: MVP 030-3 DC – DCU/TPS

- 1 TPS
- 2 DCU/HPU
- 3 MVP
- 4 Connecting cable, **order number: PM 061 350 -T**

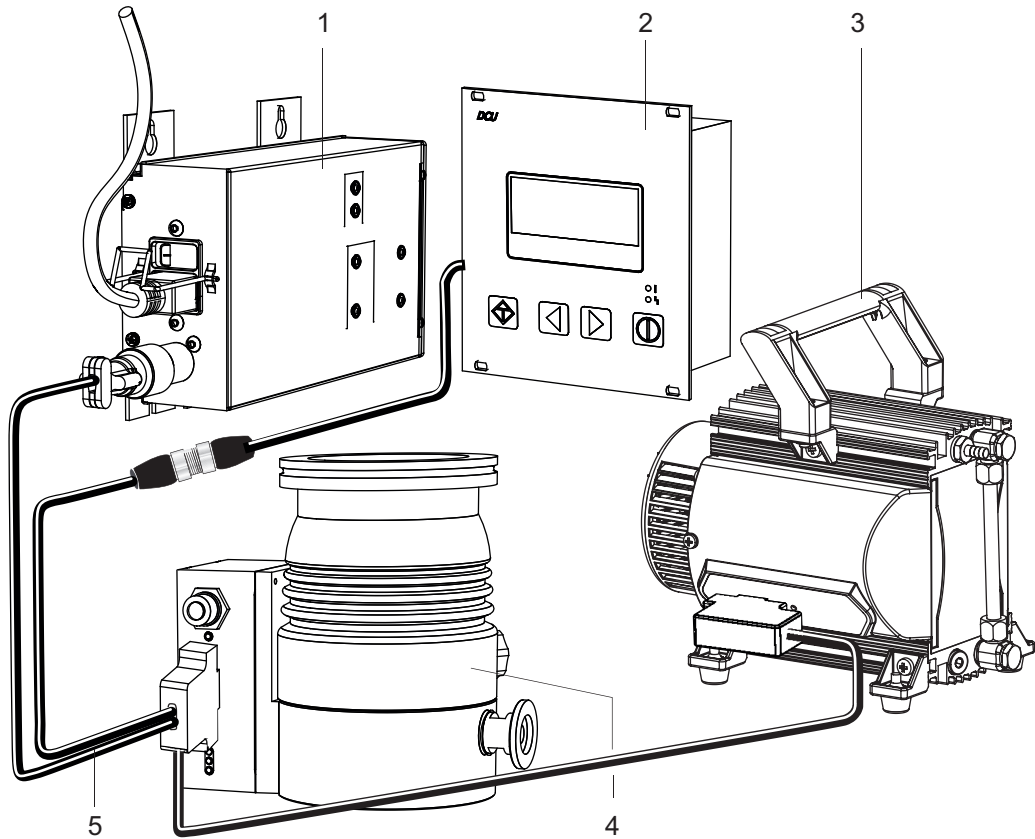

Fig. 6: Connection example: MVP 030-3 DC – HiPace/DCU/TPS

- | | |
|-----------|--|
| 1 TPS | 4 Turbopump HiPace |
| 2 DCU/HPU | 5 Connecting cable, order number: PE 100 013 -T |
| 3 MVP | |

6.1 Voltage supply

24 V DC input: The voltage supply is carried out using a connecting cable from the Pfeiffer Vacuum accessories or using a cable provided by the customer.

- **Pin 1:** +24 V DC
- **Pin 15:** Earth (GND)

24 V DC output / pin 7: Inputs 2 to 6 are activated if they are connected to pin 7 (active high) with +24 VDC. They can also be activated via an external SPS. The functions are deactivated by "SPS high level" and by "SPS low level".

- PLC High level: +13 V to +33 V
- PLC Low level: -33 V to +7 V
- R_i : 7 k Ω
- I_{max} < 200 mA

6.2 Inputs

The digital inputs switch various electronic drive unit functions. Inputs are assigned with functions ex-factory. You can configure them via the RS-485 interface and the Pfeiffer Vacuum parameter set.

DI remote priority/pin 2

V+: The "remote" connection has control priority over all other control sources.

open: Remote priority "inactive"

DI1 (rotation speed setting mode)/pin 3

V+: Rotation speed setting mode "active"

open: Rotation speed setting mode "inactive"

DI pumping station/pin 5

- V+:** Vacuum pump on.
Control of all components connected and malfunction acknowledgement.
- open:** Vacuum pump off

DI stand-by / pin 6

- V+:** Stand-by activated
The stand-by speed can be selected in the range **30 to 100%** of the nominal speed.
- GND/ open:** Stand-by off

6.3 Outputs

The digital outputs have a maximum load limit of 24 V/50 mA per output. All outputs listed are configurable with the Pfeiffer Vacuum parameter set via the RS-485 interface (description relates to factory settings).

DO1/Pin 8

- V+:** No errors
After applying the voltage supply, the digital output DO1 permanently outputs V+ meaning which means "no error".
- GND** Error
"Active low" signifies "Error" (common error message).

DO2/Pin 9

- V+:** Vacuum pump on
"Active high" means "Vacuum pump on" and rotates at set rotation speed.
Example: Use the signal for the message vacuum pump "Ready for operation".
- GND:** Vacuum pump off

6.4 Interface RS-485

⚠ DANGER

Danger to life from electric shock

When establishing the voltages that exceed the specified safety extra-low voltage (according to IEC 60449 and VDE 0100), the insulating measures will be destroyed. There is a danger to life from electric shock at the communication interfaces.

- ▶ Connect only suitable devices to the bus system.

The interface with the designation "RS-485" is intended for the connection of a Pfeiffer Vacuum display and control unit (DCU or HPU) or an external computer. The connections are galvanically safe and are isolated from the maximum supply voltage for the electronic drive unit.

Designation	Value
Serial interface	RS-485
Baudrate	9600 Baud
Data word length	8 bit
Parity	none (no parity)
Start bits	1
Stop bits	1

Tbl. 6: Features of the RS-485 interface

Connecting a Pfeiffer Vacuum display and control units or PC

- ▶ Use the connection cable from the control unit scope of delivery or from the accessories program.
- ▶ You can connect one external control unit to the RS-485 interface.
- ▶ You can connect a USB interface (PC) via the USB/RS-485 converter.

Networking as RS-485 bus

The group address of the electronic drive unit is 902.

1. Install the devices according to the specification for RS-485 interfaces.
2. Make sure that all devices connected to the bus have different RS-485 device addresses [P:797].
3. Connect all devices to the bus with RS-485 D+ and RS-485 D-.

6.5 Cross-linked via the RS-485 connection

⚠ DANGER

Danger to life from electric shock

When establishing the voltages that exceed the specified safety extra-low voltage (according to IEC 60449 and VDE 0100), the insulating measures will be destroyed. There is a danger to life from electric shock at the communication interfaces.

- ▶ Connect only suitable devices to the bus system.

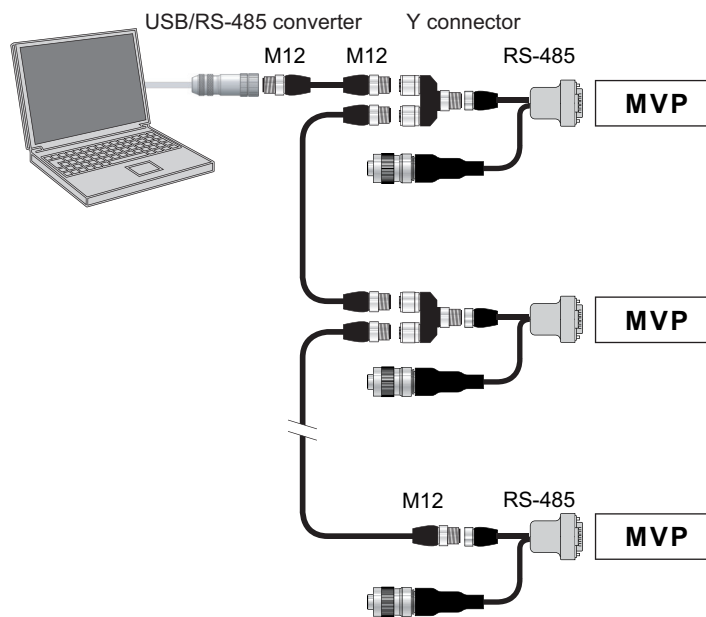

Fig. 7: Networking via the RS-485 interface

6.6 Connection options via interface RS-485

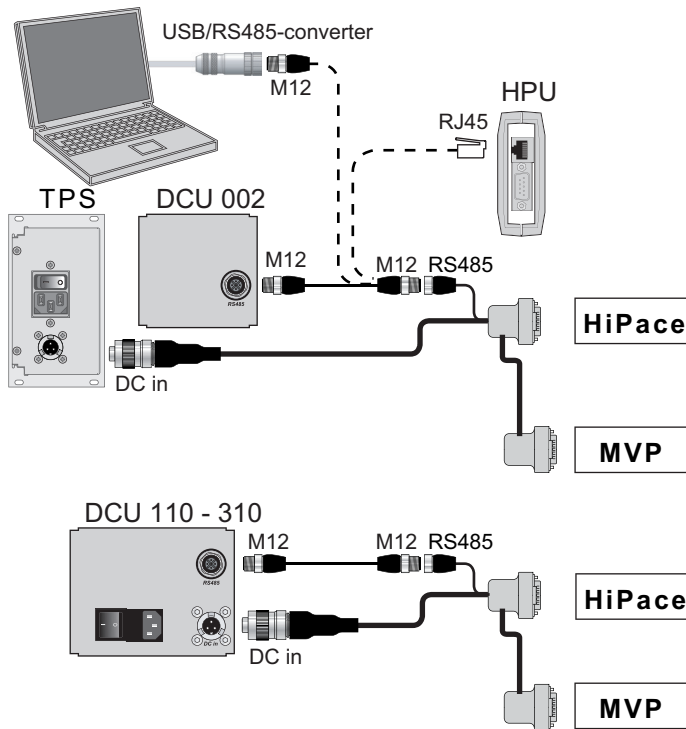

Fig. 8: Connection options via interface RS-485



Connecting Pfeiffer Vacuum display and control panels or PC

At interface RS-485, one external control panel can be connected in each case.

1. Use the respective connection cable supplied with the control panel or from the range of accessories.
2. Use the option to connect a PC via the USB/RS-485 converter.

6.7 Pfeiffer Vacuum protocol for RS-485 interface

6.7.1 Telegram frame

The telegram frame of the Pfeiffer Vacuum protocol contains only ASCII code characters [32; 127], the exception being the end character of the telegram C_R . Basically, a master  (e.g. a PC) sends a telegram, which is answered by a slave  (e.g. electronic drive unit or transmitter).

a2	a1	a0	*	0	n2	n1	n0	l1	l0	dn	...	d0	c2	c1	c0	C_R
a2 – a0				Unit address for slave 												
				<ul style="list-style-type: none"> • Individual address of the unit ["001";"255"] • Group address "9xx" for all identical units (no response) • global address "000" for all units on the bus (no response) 												
*				Action according to telegram description												
n2 – n0				Pfeiffer Vacuum parameter numbers												
l1 – l0				Data length dn to d0												
dn – d0				Data in the respective data type (see chapter "Data types", page 27).												
c2 – c0				Checksum (sum of ASCII values of cells a2 to d0) modulo 256												
C_R				carriage return (ASCII 13)												

6.7.2 Telegram description

Data query  -->  ?

a2	a1	a0	0	0	n2	n1	n0	0	2	=	?	c2	c1	c0	c _R
----	----	----	---	---	----	----	----	---	---	---	---	----	----	----	----------------

Control command  -->  !

a2	a1	a0	1	0	n2	n1	n0	l1	l0	dn	...	d0	c2	c1	c0	c _R
----	----	----	---	---	----	----	----	----	----	----	-----	----	----	----	----	----------------

Data response / Control command understood  --> 

a2	a1	a0	1	0	n2	n1	n0	l1	l0	dn	...	d0	c2	c1	c0	c _R
----	----	----	---	---	----	----	----	----	----	----	-----	----	----	----	----	----------------

Error message  --> 



a2	a1	a0	1	0	n2	n1	n0	0	6	N	O	_	D	E	F	c2	c1	c0	c _R
										_	R	A	N	G	E				
										_	L	O	G	I	C				

- NO_DEF Parameter number n2–n0 no longer exists
- _RANGE Data dn–d0 outside the permissible range
- _LOGIC Logical access error

6.7.3 Telegram example 1



Data query

Current rotation speed (parameter **[P:309]**, device address slave: "123")

 -->  ?	1	2	3	0	0	3	0	9	0	2	=	?	1	1	2	c _R
ASCII	49	50	51	48	48	51	48	57	48	50	61	63	49	49	50	13

Data response: 633 Hz



Current rotation speed (parameter **[P:309]**, device address Slave: "123")

 --> 	1	2	3	1	0	3	0	9	0	6	0	0	0	6	3	3	0	3	7	c _R
ASCII	49	50	51	49	48	51	48	57	48	54	48	48	48	54	51	51	48	51	55	13

6.7.4 Telegram example 2



Control command

Switch on the pumping station (parameter **[P:010]**, device address Slave: "042")

 -->  !	0	4	2	1	0	0	1	0	0	6	1	1	1	1	1	1	0	2	0	c _R
ASCII	48	52	50	49	48	48	49	48	48	54	49	49	49	49	49	49	48	50	48	13

Control command understood

Switch on the pumping station (parameter **[P:010]**, device address Slave: "042")

 --> 	0	4	2	1	0	0	1	0	0	6	1	1	1	1	1	1	0	2	0	c _R
ASCII	48	52	50	49	48	48	49	48	48	54	49	49	49	49	49	49	48	50	48	13

6.7.5 Data types

No.	Data type	Description	Length I1 – I0	Example
0	boolean_old	Logical value (false/true)	06	000000 corresponds with false 111111 corresponds with true
1	u_integer	Positive whole number	06	000000 to 999999
2	u_real	Positive fixed point number	06	001571 corresponds with 15.71
3	u_expo	Positive exponential number	06	1.2E-2 corresponds with $1,2 \cdot 10^{-2}$ 005E8 corresponds with $5 \cdot 10^8$
4	string	Any character string with 6 characters. ASCII codes between 32 and 127	06	TC_110, TM_700
6	boolean_new	Logical value (false/true)	01	0 corresponds with false 1 corresponds with true
7	u_short_int	Positive whole number	03	000 to 999
10	u_expo_new	Positive exponential number. The last of both digits are the exponent with a deduction of 20.	06	100023 corresponds with $1,0 \cdot 10^3$ 100000 corresponds with $1,0 \cdot 10^{-20}$
11	string16	Any character string with 16 characters. ASCII codes between 32 and 127	16	this-is-an-example
12	string8	Any character string with 8 characters. ASCII codes between 32 and 127	08	Example

7 Parameter set

7.1 General

All variables of the vacuum pump relevant for the function are stored as parameters in the electronic drive unit. Each parameter has a three-digit number and a description. Parameters can be used via Pfeiffer Vacuum display and control panels or via RS-485 with the Pfeiffer Vacuum protocol.

Conventions

Parameters are printed in bold as **three-digit numbers in square brackets**. The designation can also be specified.

Example: **[P:312] Software version**

Factory settings

The electronic drive unit is pre-programmed in the factory. This makes a more direct and safe operation of the vacuum pump possible without additional configuration.

You can configure the following parameters for the specific process:

- **[P:026]**: rotation speed setting mode on/off.
- **[P:707]**: specification of the rotation speed setting mode with 25 to 134% of the nominal rotation speed.
- **[P:002]**: stand-by mode on/off.

#	Three digit number of the parameter
Display	Display of parameter description
Description	Brief description of the parameters
Functions	Function description of the parameters
Data type	Type of formatting of the parameter for the use with the Pfeiffer Vacuum protocol
Access type	R (read): Read access; W (write): Write access
Unit	Physical unit of the described variable
min. / max.	Permissible limit values for the entry of a value
default	Factory default pre-setting (partially pump-specific)
	The parameter can be saved persistently in the electronic drive unit

Tbl. 7: Explanation and meaning of the parameters

7.2 Control commands

#	Display	Designations	Functions	Data type	Access type	Unit	min.	max.	default	can be stored
002	Standby	Standby	0 = off 1 = on	0	RW		0	1	0	x
010	Pumpg-Statn	Pump	0 = off 1 = on	0	RW		0	1	0	x
019	Cfg DO2	Configuration output DO2	1 = No error 2 = Error 5 = Set rotation speed reached 6 = Pump on 9 = "0" 10 = "1" 11 = Remote priority active	7	RW		0	20	6	x
024	Cfg DO1	Configuration output DO1	Settings, see [P:019]	7	RW		0	20	1	x

#	Display	Designations	Functions	Data type	Access type	Unit	min.	max.	default	can be stored
026	SpdSet-Mode	Speed actuator operation	0 = off 1 = on	7	RW		0	1	0	x
060	CtrlVialnt	Operation of the interface	1 = remote 2 = RS-485 4 = PV.can 32 = Keys on the front panel 255 = Interface selection	7	RW		1	255	1	x
061	IntSelLckd	Interface selection locked	0 = off 1 = on	0	RW		0	1	0	x

Tbl. 8: Parameter set | Control commands

7.3 Status requests

#	Display	Designations	Functions	Data type	Access type	Unit	min.	max.	default	can be stored
303	Error code	Error code		4	R					
309	ActualSpd	Actual rotational speed (Hz)		1	R	Hz				
310	DrvCurrent	Drive current		2	R	A	0	9999.99		
311	OpHrsPump	Pump operating hours		1	R	h				x
312	Fw version	Software version interface circuit board		4	R					
313	DrvVoltage	Supply voltage	Voltage in x.xx V	2	R	R				
315	Nominal Spd	Nominal rotational speed (Hz)		1	R	Hz				
316	DrvPower	Drive power	Output in xW	1	R	W				
330	TempPump	Pump temperature		1	R	°C	0	999999		
349	ElecName	Device name designation		4	R					
352	FWVERSDRV	Firmware of the FC		4	R					
354	HW Version	Hardware version interface circuit board		4	R					
398	ActualSpd	Actual speed (rpm)		1	R	rpm				
399	NominalSpd	Nominal rotation speed (rpm)		1	R	rpm				

Tbl. 9: Parameter set | Status requests

7.4 Reference value inputs

#	Display	Designations	Functions	Data type	Access type	Unit	min.	max.	default	can be stored
707	SpdSVal	Setpoint in speed-control operation	Set rotation speed in x.x% of the nominal rotation speed	2	RW	%	25	170	75	x
717	StdbysVal	Rotational speed setpoint in standby operation		2	RW	%	30	100	66.7	x
797	RS485Adr	RS-485 Interface address		1	RW		1	255	1	x

Tbl. 10: Parameter set | Reference value inputs

7.5 Additional parameter for the DCU



Additional parameter in the control panel

The basic parameter set is set in the electronic drive unit ex-factory. For controlling connected external components (e.g. vacuum measuring instruments), additional parameters (extended parameter set) are available in the corresponding Pfeiffer Vacuum display and control panels.

- Refer to the corresponding operating instructions of the respective components.
- Select the extended parameter set with parameter **[P:794] = 1**.

#	Display	Description	Functions	Data type	Access type	Unit	min.	max.	default	
340	Pressure	Actual pressure value (ActiveLine)		7	R	hPa	$1 \cdot 10^{-10}$	$1 \cdot 10^3$		
350	Ctr Name	Display and control panel: type		4	R					
351	Ctr Software	Display and control panel: software version		4	R					
738	Gauge type	Type of pressure gauge		4	RW					
794	Param set	Parameter set	0 = Basic parameter set 1 = Extended parameter set	7	RW		0	1	0	
795	Servicelin	Insert service line		7	RW				795	

Tbl. 11: Parameter for DCU functions

8 Operation

8.1 Putting the vacuum pump into operation

Important settings and function-related variables are factory-programmed into the vacuum pump electronic drive unit as parameters. Each parameter has a three-digit number and a description. Parameter-driven operation and control is supported via Pfeiffer Vacuum displays and control units, or externally via RS-485 using Pfeiffer Vacuum protocol.

WARNING

Danger of poisoning due to toxic process media escaping from the exhaust pipe

During operation with no exhaust line, the vacuum pump allows exhaust gases and vapors to escape freely into the air. There is a risk of injury and fatality due to poisoning in processes with toxic process media.

- ▶ Observe the pertinent regulations for handling toxic process media.
- ▶ Safely purge toxic process media via an exhaust line.
- ▶ Use appropriate filter equipment to separate toxic process media.

NOTICE

Vacuum pump damage caused by overpressure

Mixing up the connections causes overpressure overload. The vacuum pump can be started only against max. 1 bar differential pressure between inlet and outlet; otherwise the motor jams and sustains damage.

- ▶ Make sure that the distributor is installed correctly on the diaphragm heads, before connecting the vacuum pump to the vacuum equipment.
- ▶ Before commissioning, make completely sure that the pressure side pressure is below the permissible limit.

Parameter	Name	Designation	Adjustment, setting
[P:707]	SpdSVal	Speed-control operation specification	75 %

Tbl. 12: Factory setting of the electronic drive unit for diaphragm pumps when delivered

Procedure

1. Compare the frequency specifications on the rating plate with the available supply voltage.
2. Check the exhaust connection for free passage (max. permissible pressure: 1100 hPa absolute).
3. Actuate the shut-off units so that the shut-off units open before or at the same time as the vacuum pump starts up.

8.2 Switching on the vacuum pump

When pumping down dry gases, no special precautions are required.

CAUTION

Danger of burns on hot surfaces

Depending on the operating and ambient conditions, the surface temperature of the vacuum pump can increase to above 70 °C.

- ▶ Provide suitable touch protection.

Prerequisite

- required cable connections are established

Switching on the vacuum pump

1. If required, switch the vacuum pump on in each pressure range in one of the 3 possible ways:
 - using a mains switch on the power supply pack with respective bridges on the 15-pin D-Sub socket
 - via the peripheral devices DCU/HPU
 - using the PLC control unit on the 15-pin D-Sub socket
2. Allow the vacuum pump to warm up prior to process start, with the vacuum connection closed.
 - The warm-up time depends on the ambient temperature and may take between 15 and 30 minutes.

The vacuum pump achieves the specified throughput and ultimate pressure values once the operating temperature has been reached.

8.3 Configuring the connections with the Pfeiffer Vacuum parameter set

The electronic drive unit is pre-configured with the factory default basic functions and is ready for operation. For individual requirements, you can configure most connections for the electronic drive unit with the parameter set.

8.3.1 Configuring the digital outputs

Option	Description
1 = No error	active, with trouble-free operation
2 = Error	active, if the error message is active
5 = Set rotation speed reached	active, once the set rotation speed is reached
6 = Pump on	active, if pump on, motor on and no error
9 = always 0	GND for the control of an external device
10 = always 1	V+ for the control of an external device
11 = Remote	active, if the remote priority is active

Tbl. 13: Configure parameters [P:019] and [P:024]

Procedure

- ▶ Perform the configuration according to the table.

8.3.2 Selecting the interfaces

Option [P:060]	Description
1 = remote	Operation via connection "remote"
2 = RS-485	Operation via connection "RS-485"
4 = PV.can	For service purposes only
32 = Keys on the front panel	Manual operation
Option [P:061]	
0 = off	Interface selection can be set via [P:060].
1 = on	Interface selection locked

Tbl. 14: Parameters [P:060] and [P:061]

Procedure

- ▶ Select the interface according to the table.

8.4 Operating modes

The following operating modes are possible:

- Operation without control unit
- Operation via an external control unit
- Operation via RS-485 and Pfeiffer Vacuum display and control unit or PC

The connection of a Pfeiffer Vacuum display and control panel permits the controlling of the vacuum pump via the parameters fixed in the electronic drive unit.



Automatic start

After bypassing the contacts at pins 2, 7, 5 on the connecting plug or when using a connecting cable with respective bridges and applying the supply voltage, the vacuum pump starts up immediately.

Pfeiffer Vacuum therefore recommends switching on the voltage supply immediately before operation.

Operate without control unit

1. Connect the respective connecting cable with bridges to the power supply plug of the electronic drive unit.
2. Provide the current supply for the power supply pack.
3. Switch on the power supply pack with switch S1.

After applying the operating voltage, the vacuum pump carries out a self-test to check the supply voltage. After a successfully completed self-test, the vacuum pump starts.

Operate via the external control

- ▶ Connect the remote control via the 15-pin D-Sub socket.

The control is carried out by means of "PLC level".

Operate with peripheral devices DCU or HPU.

1. When handling the Pfeiffer Vacuum display and control unit, observe the associated operating instructions:
 - "DCU" operating instructions available from the [Download Center](#).
 - "HPU" operating instructions available from the [Download Center](#).
2. Connect the respective peripheral device to the 15-pin D-Sub socket.
3. Switch on the power supply pack with switch S1 or on the peripheral device.
4. Make the desired settings via the RS-485 using the peripheral device.

8.4.1 Speed actuator operation

The set rotation speed is selected via the parameter **[P:707]** in the range **30 to 134%** of the set rotation speed. If the speed is higher than the set rotation speed (> 100%), an increased pump wear is possible.

The rotation speed setting mode has priority over the stand-by mode.



Permissible rotation speed range of the vacuum pump

Parameterization in rotation speed setting mode is subject to the permissible rotation speed range of the respective vacuum pump. The electronic drive unit regulates automatically to the next valid value.

Set the rotation speed setting mode

1. Set the parameter **[P:707]** to the required value in %.
2. Set the parameter **[P:026]** to "1".
3. Check the set rotation speed (parameter **[P:308]** or **[P:397]**).

8.4.2 Standby mode

Pfeiffer Vacuum recommends standby mode for during process and production stops. With active stand-by mode, the electronic drive unit reduces the speed of the vacuum pump in the range of **30 to 100%** of the nominal speed. The factory setting is 66.7% of the nominal speed.

Setting the related parameters

1. Set the parameter **[P:717]** to the required value in %.
2. Set the parameter **[P:026]** to "0".
3. Set the parameter **[P:002]** to "1".
4. Check the set rotation speed (parameter **[P:308]** or **[P:397]**).

8.4.3 Normal operation

The vacuum pump starts in boost mode for max. 5 minutes with the maximum speed. The current is monitored at the same time. If the current is below a threshold value, the speed is controlled down to nominal rotation speed. In case the power input increases again, automatic increase of the speed does not take place. An increase in speed is reached again after vacuum pump stop / start.

Setting the related parameters

1. Set the parameter **[P:002]** to "0".
2. Set the parameter **[P:026]** to "0".
3. Check the set rotation speed (parameter **[P:308]**).

8.5 Pumping condensable vapors

Vapors or moisture from pumped media impair the throughput after condensation in the vacuum pump.

⚠ WARNING

Risk of explosion from reactive, explosive or other hazardous gas / air mixtures.

Uncontrolled inlet of gas at the flushing gas nozzle leads to sparks generated mechanically following diaphragm rupture, hot surfaces or to explosive gas / air mixtures in the vacuum system caused by static electricity.

- ▶ If necessary, use inert gas for supplying the flushing gas in order to avoid a potential ignition.

⚠ CAUTION

Risk of poisoning due to toxic process gases escaping

For intake pressures > 500 hPa, process gas may escape from the flushing gas nozzle.

- ▶ If necessary, use an extraction line.

Required tool

- Allen key, **WAF 5**

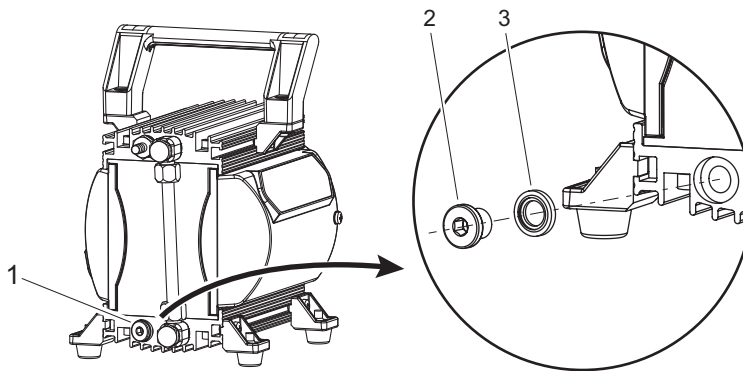

Fig. 9: Mounting the flushing gas nozzle

- 1 Locking screw, G 1/8"
- 2 Flushing gas nozzle (0.3 mm)
- 3 Seal

Mounting the flushing gas nozzle







Using the optional flushing gas nozzle improves the discharge of condensate, and the pump achieves the specified final vacuum more quickly.

1. Screw in the flushing gas nozzle instead of the locking screw.
2. Bring the vacuum pump to operating temperature before starting the process.
3. Continue to operate the vacuum pump approx. 30 minutes after finishing the process before switching it off.

8.6 Operation monitoring

8.6.1 Operating mode display via LED

The LED on the electronic drive unit indicates the basic operating conditions. A differentiated malfunction and warning display is possible only for operation with DCU or HPU.

Display	Activity	Meaning
	None	<ul style="list-style-type: none"> No adequate power supply
	10% active, 1 Hz	<ul style="list-style-type: none"> No errors Vacuum pump "OFF" Vacuum pump stationary
	50 % active, 1 Hz	<ul style="list-style-type: none"> No errors Vacuum pump "OFF" Vacuum pump still rotating
	90 % active, 1 Hz	<ul style="list-style-type: none"> No errors Vacuum pump "ON" Set rotation speed not reached
	100% active	<ul style="list-style-type: none"> No errors Vacuum pump "ON" Target speed reached
	50% active, 10, Hz	<ul style="list-style-type: none"> Defect

Tbl. 15: Behavior and meaning of the LED of the electronic drive unit

8.6.2 Temperature monitoring

If the pump temperature becomes too high ($> 75\text{ °C}$), the electronic drive unit reduces the motor rotation speed to the nominal rotation speed to prevent the vacuum pump from overheating.

After cooling down ($< 72\text{ °C}$), the vacuum pump starts to run at set rotation speed.

8.7 Switching off the vacuum pump

Procedure

1. Allow the vacuum pump to run on for 5 to 10 minutes with the vacuum connection open to allow any condensate that may be present to be removed from the vacuum pump.
2. If required, switch the vacuum pump off in each pressure range.
3. Disconnect the voltage supply on the power supply pack.

9 Maintenance

9.1 Maintenance instructions

⚠ WARNING

Health hazard through poisoning from toxic contaminated components or devices

Toxic process media result in contamination of devices or parts of them. During maintenance work, there is a risk to health from contact with these poisonous substances. Illegal disposal of toxic substances causes environmental damage.

- ▶ Take suitable safety precautions and prevent health hazards or environmental pollution by toxic process media.
- ▶ Decontaminate affected parts before carrying out maintenance work.
- ▶ Wear protective equipment.

⚠ CAUTION

Danger of injury from moving parts

After a power failure or a standstill as a result of overheating, the motor restarts automatically. There is a risk of injury to fingers and hands if they enter the operating range of rotating parts.

- ▶ Safely disconnect motor from the mains.
- ▶ Secure the motor against reactivation.
- ▶ Dismantle the vacuum pump for inspection, away from the system if necessary.

NOTICE

Damage caused by unsuitable cleaning agents

Unsuitable cleaning agents damage pump parts.

- ▶ Use only approved cleaning agents to clean pump parts.
- ▶ Use only a clean dry cloth to clean the diaphragms and valves.
- ▶ Do not use any alcohol or other cleaning agents to clean the diaphragms and valves.

NOTICE

Danger of property damage from improper maintenance

Unprofessional work on the vacuum pump will lead to damage for which Pfeiffer Vacuum accepts no liability.

- ▶ We recommend taking advantage of our service training offering.
- ▶ When ordering spare parts, specify the information on the nameplate.

The following section describes the tasks for cleaning and maintaining the vacuum pump. Valves and diaphragms are wear parts.

Component	Operating hours
Diaphragms	15 000
Valves	15 000
Motor bearing	40 000

Tbl. 16: Typical service life with normal use

Prerequisites

- Vacuum pump switched off
- Vacuum pump vented from atmospheric pressure
- Vacuum pump cooled

Required materials

- Cloth (clean, lint-free)
- Water or mild soap solution

Servicing the vacuum pump

1. Disconnect the vacuum pump from the voltage supply.
2. Secure the motor against reactivation.
3. Remove any external contamination on the vacuum pump with cloth slightly moistened with water or a mild soap solution.
4. Allow all cleaned parts to dry well.
5. For maintenance work, only dismantle the vacuum pump to the extend needed.
6. Clean the suction chamber, diaphragms, and valves with a dry cloth.
7. Examine the diaphragms and valves for cracks at the latest when the pressure values achieved decrease.

9.2 Checklist for inspection and maintenance



Notes on maintenance intervals

Depending on the process, the required maintenance intervals may be shorter than the reference values specified in the table.

- Consult with Pfeiffer Vacuum Service about shorter maintenance intervals for extreme loads or for specific processes.



Maintenance level 2

We recommend that Pfeiffer Vacuum Service carry out maintenance work at level 2. If the specified intervals are exceeded, or if maintenance work is carried out improperly, no warranty or liability claims are accepted on the part of Pfeiffer Vacuum. This also applies wherever parts other than original spare parts are used.

Action	Inspection		Maintenance level 2		Required material
	daily	as required; at least once every six months	as required; after 15000 hours at the latest	as required; at least every 2 years	
Check silencer for contamination		■			
Clean the vacuum pump			■		Overhaul kit
Change the diaphragms and valves					
Change silencer				■	

Tbl. 17: Maintenance intervals

9.3 Dismantling / installing the handle

Required tools

- Phillips head (crosshead) screwdriver, **size 2**

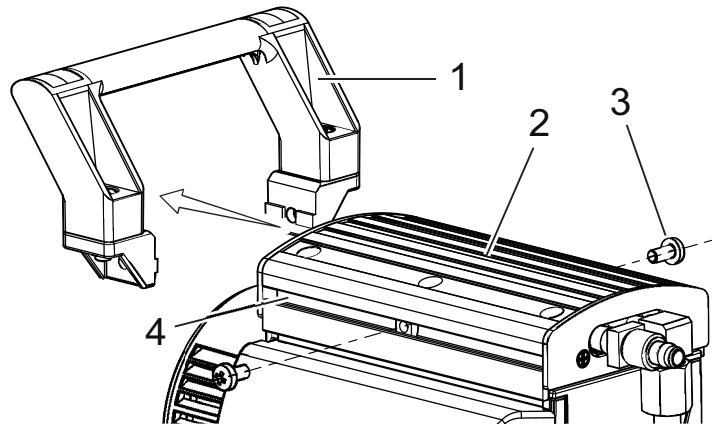

Fig. 10: Handle

- | | |
|-----------------|--------------|
| 1 Handle | 3 Screw (2×) |
| 2 Housing cover | 4 Groove |

Dismantling the handle

1. Loosen the screws of the handle.
2. Push the handle from the groove in the housing cover.

Installing the handle

1. Push the handle into the groove in the housing cover.
2. Pay attention to the correct position of the handle above the center of gravity of the vacuum pump.
3. Fasten the screws of the handle to the nuts in the housing cover.

9.4 Change the diaphragms and valves

NOTICE

Property damage from incorrect installation

Changed dead volume due to incorrect installation of the original spacer disks worsens the final vacuum or leads to bearing damage.

- ▶ During disassembly, keep the existing spacer disks separate per installation location.
- ▶ Reinstall the same number of original spacer disks per diaphragm head.

9.4.1 Dismantle the pump head and valves



Avoid interchanging components

Always dismantle and mount only the pump head on one pump side in order to avoid interchanging the components.

The procedures are identical for both pump heads.

Prerequisites

- Handle dismantled
- Diaphragm pump supported

Required tools

- Open-end wrench, **WAF 15**
- Open-end wrench, **WAF 16**
- Allen key, **WAF 4**

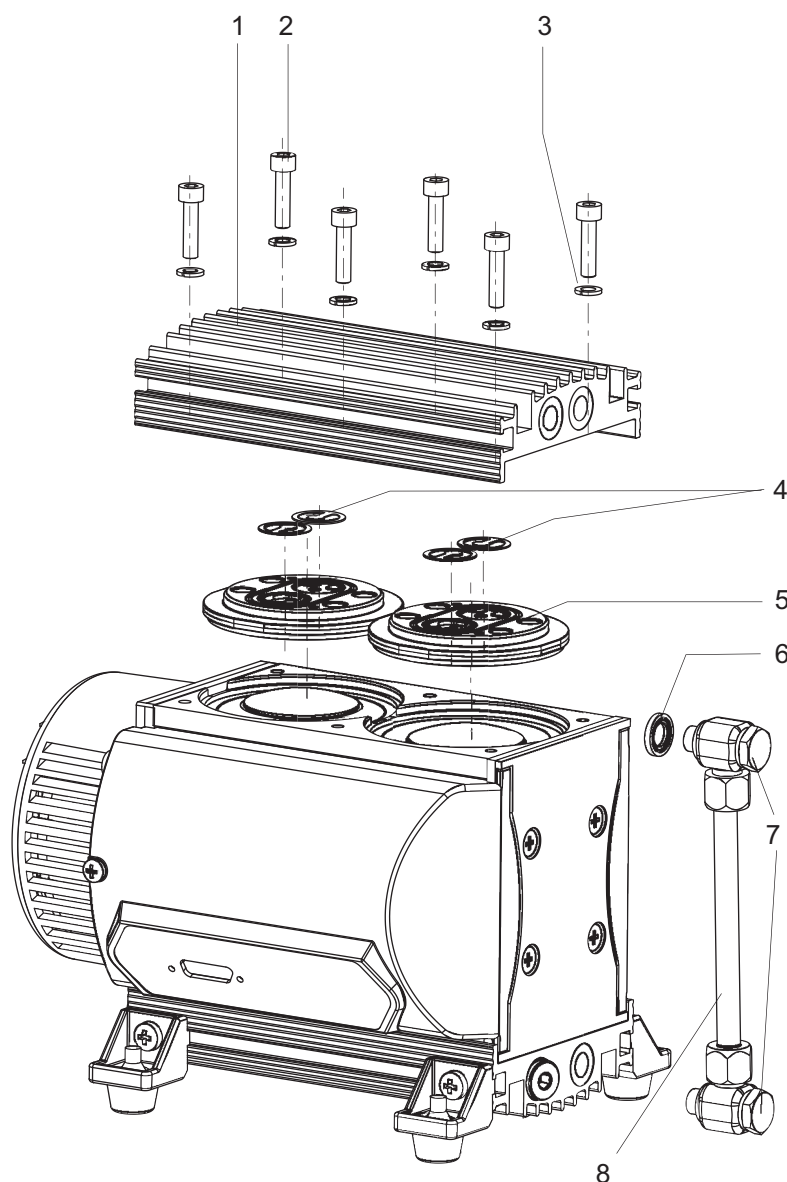

Fig. 11: Pump head and valves

- | | |
|-----------------------|---------------------|
| 1 Housing cover 1 | 5 Head cover (2×) |
| 2 Cylinder screw (6×) | 6 Sealing ring (2×) |
| 3 Lock washer (6×) | 7 Banjo bolt (2×) |
| 4 Valve (4×) | 8 Hose connection |

Procedure

1. Loosen the screw fitting.
2. Turn the elbow fitting max. 1/4 revolution anti-clockwise, until the hose connection can be loosened.
3. Loosen the screw fitting.
4. Dismantle the hose connection.
5. Unscrew the cylinder screws on the housing cover.
6. Remove the housing cover.
7. Remove the head cover each with both valves.
 - If the valves stick to the housing cover, carefully release the valves; otherwise, remove the valves from the head covers.

9.4.2 Dismantling the diaphragms

Prerequisite

- Pump head and valves dismantled

Required tools

- Diaphragm key **WAF 46**

Spare parts required

- Overhaul kit incl. diaphragm key

Required consumables

- Clean, dry cloth
- Alcohol or cleaning solvent, if necessary

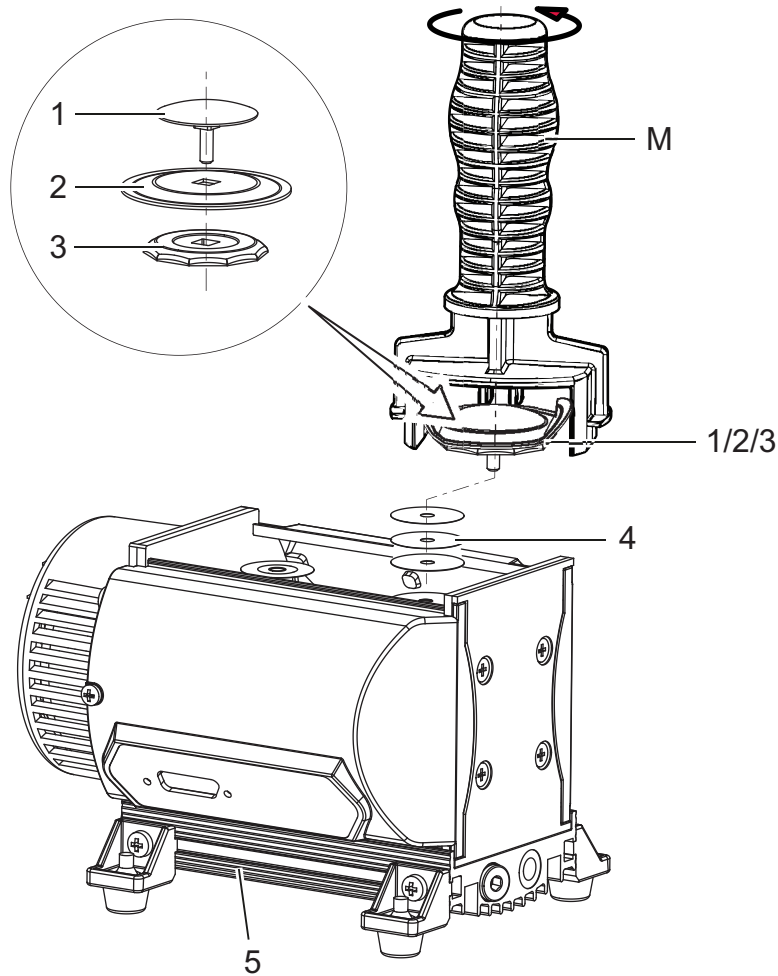

Fig. 12: Replacing the diaphragms

- | | |
|---------------------|-----------------|
| 1 Clamping washer | 4 Spacer disks |
| 2 Diaphragm | 5 Pump head 2 |
| 3 Supporting washer | M Diaphragm key |

Dismantling the diaphragms

1. Carefully bend the diaphragm up on the side and while it is bent, attach the diaphragm key to the supporting washer.
 - Do not use a sharp-edged tool.
2. Unscrew the supporting washer, diaphragm, and clamping washer.
3. Pay attention to the spacer disks under the diaphragm.
 - Reuse the original spacer disks for each installation location when remounting.
4. Remove the supporting washer and the diaphragm from the square of the clamping washer connecting screw.
 - If the diaphragm is stuck to the supporting washer, use alcohol or cleaning solvent to release it.

9.4.3 Installing the diaphragm

Required tools

- Diaphragm key **WAF 46**

Spare parts required

- Overhaul kit incl. diaphragm key

Required consumables

- Clean, dry cloth
- Alcohol or cleaning solvent, if necessary

Installing the diaphragms

1. Clean all parts with a dry, clean cloth.
2. Replace the wearing parts (valves and diaphragms) as per the spare parts pack.
3. Place the diaphragm (blue side up) and the supporting washer on the square of the clamping washer connecting screw.
 - Pay attention to the seating of the diaphragm in the square of the connecting screw.
4. Place the original spacer disks on the respective connection rod.
5. Tighten the supporting washer with the diaphragm key on the connection rod.

9.4.4 Installing the pump head and valves



Avoid interchanging components

Always dismantle and mount only the pump head on one pump side in order to avoid interchanging the components.

The procedures are identical for both pump heads.

Prerequisite

- Diaphragms installed

Required tools

- Open-end wrench, **WAF 15**
- Open-end wrench, **WAF 16**
- Allen key, **WAF 4**
- Calibrated torque wrench (tightening factor ≤ 1.6)

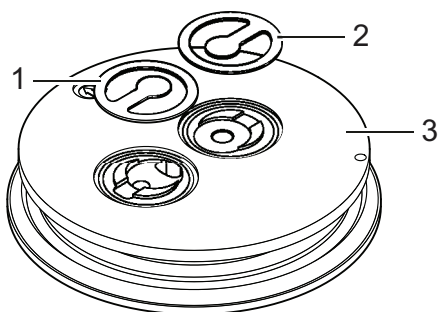

Fig. 13: Correct mounting orientation of the valves in the head cover

- | | |
|------------------|--------------|
| 1 Valve (inlet) | 3 Head cover |
| 2 Valve (outlet) | |

Procedure

1. Insert the valves into the head cover.
 - Make sure that the valves have the correct mounting orientation.
2. Mount the housing cover.
3. First, screw on the cylinder screws of the housing cover loosely by hand, alternating screws in a diagonal pattern.
4. Then tighten the cylinder screws of the housing cover, alternating screws in a diagonal pattern.
 - Tightening torque: **max. 6.0 ±1 Nm**
5. Mount the hose connection and the banjo bolts.

9.5 Checking the ultimate pressure

The leakage rate of the vacuum pump ensures that the specified ultimate pressure is reached and prevents the formation of potentially explosive mixtures in the interior of the vacuum pump

After the diaphragm or valve is replaced, the vacuum pump reaches the specified ultimate pressure value only after a run-in period of several hours.

Procedure

1. Measure the ultimate pressure of the vacuum pump.
 - after work on the system, e.g., maintenance
 - before the vacuum pump is reinserted
2. Compare the measured ultimate pressure with the test values and the specifications in the technical data.



Test values

Observe the separate test specification.

- with gas ballast: < 3 hPa
- without gas ballast: < 2.0 hPa

Prerequisites

- Vacuum pump mounted
- Vacuum pump correctly installed electrically

Required aids

- Vacuum chamber (3 liter)
- Pressure gauge
- Flushing gas nozzle

Measure the ultimate pressure

1. Connect a vacuum chamber (volume approx. 3 l) to a vacuum connection.
2. Also connect a pressure gauge (e.g. Pirani gauge) to the vacuum chamber on the vacuum side.
3. Operate the vacuum pump with open flushing gas nozzle for at least 2 hours.
4. If unusual noises develop, immediately switch off the vacuum pump and check the position of the clamping washers.
5. Measure the ultimate pressure.

Comparing the ultimate pressure with the test value

1. Compare the measured ultimate pressure with the test value.
2. If the values differ significantly from the specified values after replacing the diaphragm and valve, and if there are no changes after a run-in period, perform the following steps:
 - Check the compression couplings of the connection hoses to the pump heads.
 - Check the valve seats and the suction chambers.
 - Repeat the ultimate pressure measurement.

10 Decommissioning

Before shutting down the vacuum pump, observe the following instructions to adequately protect the interior of the vacuum pump (suction chamber) from corrosion:

Procedure for temporary vacuum pump shutdowns

1. Allow the vacuum pump to run on for 5 to 10 minutes with the vacuum connection open to allow any condensate that may be present to be removed from the vacuum pump.
2. If media has entered the vacuum pump that may attack the pump materials or lead to deposits, clean the inside of the pump heads.

Procedure for longer vacuum pump shutdowns

1. Disconnect the vacuum pump from the vacuum system.
2. Remove the vacuum pump from the vacuum system if necessary.
3. Seal the vacuum connection with the original sealing plugs.
4. Store the vacuum pump in dry, dust-free rooms, within the specified ambient conditions.
5. Pack the vacuum pump together with a drying agent in a plastic bag, and seal the vacuum pump airtight if it is to be stored in rooms with damp or aggressive atmospheres.

11 Recycling and disposal

WARNING

Health hazard through poisoning from toxic contaminated components or devices

Toxic process media result in contamination of devices or parts of them. During maintenance work, there is a risk to health from contact with these poisonous substances. Illegal disposal of toxic substances causes environmental damage.

- ▶ Take suitable safety precautions and prevent health hazards or environmental pollution by toxic process media.
- ▶ Decontaminate affected parts before carrying out maintenance work.
- ▶ Wear protective equipment.



Environmental protection

You **must** dispose of the product and its components in accordance with all applicable regulations for protecting people, the environment and nature.

- Help to reduce the wastage of natural resources.
- Prevent contamination.



Environmental protection

The product and its components **must be disposed of in accordance with the applicable regulations relating to environmental protection and human health**, with a view to reducing natural resource wastage and preventing pollution.

11.1 General disposal information

Pfeiffer Vacuum products contain materials that you must recycle.

- ▶ Dispose of our products according to the following:
 - Iron
 - Aluminium
 - Copper
 - Synthetic
 - Electronic components
 - Oil and fat, solvent-free
- ▶ Observe the special precautionary measures when disposing of:
 - Fluoroelastomers (FKM)
 - Potentially contaminated components that come into contact with media

11.2 Dispose of diaphragm pumps

Pfeiffer Vacuum diaphragm pumps contain materials that you must recycle.

1. Disconnect the electronic drive unit.
2. Dismantle the motor.
3. Decontaminate the components that come into contact with process gases.
4. Separate the components into recyclable materials.
5. Recycle the non-contaminated components.
6. Dispose of the product or components in a safe manner according to locally applicable regulations.

12 Malfunctions

12.1 General

⚠ CAUTION

Danger of injury from moving parts

After a power failure or a standstill as a result of overheating, the motor restarts automatically. There is a risk of injury to fingers and hands if they enter the operating range of rotating parts.

- ▶ Safely disconnect motor from the mains.
- ▶ Secure the motor against reactivation.
- ▶ Dismantle the vacuum pump for inspection, away from the system if necessary.

⚠ CAUTION

Danger of burns on hot surfaces

In the event of a fault, the surface temperature of the vacuum pump can increase to above 105 °C.

- ▶ Allow the vacuum pump to cool down before carrying out any work.
- ▶ Wear personal protective equipment if necessary.

NOTICE

Danger of property damage from improper maintenance

Unprofessional work on the vacuum pump will lead to damage for which Pfeiffer Vacuum accepts no liability.

- ▶ We recommend taking advantage of our service training offering.
- ▶ When ordering spare parts, specify the information on the nameplate.

Vacuum pump and electronic drive unit malfunctions always result in a warning or error message. In both cases, you will receive an error code that you can read out via the interface of the electronic drive unit. If an error occurs, the vacuum pump switches off.

Should malfunctions occur, you can find information about potential causes and how to fix them here:

Problem	Possible causes	Remedy
Vacuum pump will not start up	<ul style="list-style-type: none"> • No supply voltage or voltage does not correspond to the motor data 	<ul style="list-style-type: none"> • Check the supply voltage.
	<ul style="list-style-type: none"> • Pump temperature too low 	<ul style="list-style-type: none"> • Heat the vacuum pump to a temperature of > 5°C.
	<ul style="list-style-type: none"> • Thermal protection of the motor has triggered 	<ul style="list-style-type: none"> • Identify and eliminate the cause and allow vacuum pump to cool if necessary.
	<ul style="list-style-type: none"> • Diaphragms or valves dirty 	<ul style="list-style-type: none"> • Clean the vacuum pump.
	<ul style="list-style-type: none"> • Overpressure in the exhaust lead 	<ul style="list-style-type: none"> • If required, check and clean the exhaust line.
Vacuum pump switches off after a while after being started	<ul style="list-style-type: none"> • Thermal protection of the motor has triggered 	<ul style="list-style-type: none"> • Identify and eliminate the cause and allow vacuum pump to cool if necessary.
	<ul style="list-style-type: none"> • Exhaust pressure too high 	<ul style="list-style-type: none"> • Check exhaust line outlet opening and exhaust side accessories.

Problem	Possible causes	Remedy
Vacuum pump does not reach the specified ultimate pressure	<ul style="list-style-type: none"> • Condensate in the vacuum pump 	<ul style="list-style-type: none"> • Operate the vacuum pump at atmospheric pressure for a longer period.
	<ul style="list-style-type: none"> • Flushing gas nozzle/gas ballast valve open 	<ul style="list-style-type: none"> • Close the flushing gas nozzle/the gas ballast valve.
	<ul style="list-style-type: none"> • Soiled valves or diaphragms 	<ul style="list-style-type: none"> • If necessary, clean or replace the valves and diaphragms.
	<ul style="list-style-type: none"> • Leak in system 	<ul style="list-style-type: none"> • Locate and eliminate the leak.
Pumping speed of vacuum pump too low	<ul style="list-style-type: none"> • The intake line is not suitably dimensioned 	<ul style="list-style-type: none"> • Make sure that connections are short and cross sections adequately dimensioned.
	<ul style="list-style-type: none"> • Exhaust pressure too high 	<ul style="list-style-type: none"> • Check exhaust line outlet opening and exhaust side accessories.
Unusual noises during operation	<ul style="list-style-type: none"> • Defective valves or diaphragms 	<ul style="list-style-type: none"> • If necessary, clean or replace the valves and diaphragms.
	<ul style="list-style-type: none"> • Soiled suction chamber 	<ul style="list-style-type: none"> • Clean suction chamber.
	<ul style="list-style-type: none"> • The silencer is loose or missing 	<ul style="list-style-type: none"> • If necessary, check or replace the silencer.
	<ul style="list-style-type: none"> • Valves dirty or defective 	<ul style="list-style-type: none"> • If necessary, clean or replace the valves and diaphragms.
	<ul style="list-style-type: none"> • Connection rod or motor bearing defective 	<ul style="list-style-type: none"> • Contact Pfeiffer Vacuum Service.

Tbl. 18: Troubleshooting on diaphragm pumps

12.2 Error codes

Errors (** Error E—— **) always cause the vacuum pump to be switched off.

Warnings (* Warning F —— *) do not cause the vacuum pump to be switched off.

Handling malfunction messages

1. Read out the error codes via the display and control panel or the PC.
2. Remove the cause of the malfunction.
3. Reset the error message with parameter **[P:009]** or by pressing the button  on the DCU.

Error code	Problem	Possible causes	Remedy
Err098	Internal communication error between interface board and drive	–	<ul style="list-style-type: none"> • Contact Pfeiffer Vacuum Service.
Err117	Vacuum pump excess temperature (> 90 °C)	<ul style="list-style-type: none"> • Insufficient cooling 	<ul style="list-style-type: none"> • Improve the cooling • Check the operating conditions
Err174	Vacuum pump blocked	–	<ul style="list-style-type: none"> • Contact Pfeiffer Vacuum Service.

Tbl. 19: Error messages for vacuum pump

Error code	Problem	Possible causes	Remedy
Wrn117	High temperature vacuum pump (> 75 °C)	<ul style="list-style-type: none"> • Insufficient cooling 	<ul style="list-style-type: none"> • Improve the cooling • Check the operating conditions

Tbl. 20: Warning messages for vacuum pump

12.3 Warning and error messages when operating with DCU

Besides the device-specific warning and error messages on the electronic drive unit, additional messages are displayed with the connected display and control panel.

Display in DCU	Problem	Possible causes	Remedy
* Warning F110 *	Pressure gauge	<ul style="list-style-type: none"> Pressure gauge faulty Connection to the pressure gauge disconnected during operation 	<ul style="list-style-type: none"> Check the cable connection Carry out a restart with pressure gauge connected Replace the pressure gauge completely
** Error E040 **	Hardware error	<ul style="list-style-type: none"> external RAM faulty 	<ul style="list-style-type: none"> Contact Pfeiffer Vacuum Service.
** Error E042 **	Hardware error	<ul style="list-style-type: none"> EPROM checksum incorrect 	<ul style="list-style-type: none"> Contact Pfeiffer Vacuum Service.
** Error E043 **	Hardware error	<ul style="list-style-type: none"> E²PROM write error 	<ul style="list-style-type: none"> Contact Pfeiffer Vacuum Service.
** Error E090 **	Internal device error	<ul style="list-style-type: none"> RAM not large enough DCU is connected to incorrect electronic drive unit 	<ul style="list-style-type: none"> Contact Pfeiffer Vacuum Service. Connect the DCU to the correct electronic drive unit
** Error E698 **	Communication error	<ul style="list-style-type: none"> Electronic drive unit is not responding 	<ul style="list-style-type: none"> Contact Pfeiffer Vacuum Service.

Tbl. 21: Warning and error messages when using a DCU

13 Service solutions by Pfeiffer Vacuum

We offer first-class service

High vacuum component service life, in combination with low downtime, are clear expectations that you place on us. We meet your needs with efficient products and outstanding service.

We are always focused on perfecting our core competence – servicing of vacuum components. Once you have purchased a product from Pfeiffer Vacuum, our service is far from over. This is often exactly where service begins. Obviously, in proven Pfeiffer Vacuum quality.

Our professional sales and service employees are available to provide you with reliable assistance, worldwide. Pfeiffer Vacuum offers an entire range of services, from [original replacement parts](#) to [service contracts](#).

Make use of Pfeiffer Vacuum service

Whether preventive, on-site service carried out by our field service, fast replacement with mint condition replacement products, or repair carried out in a [Service Center](#) near you – you have various options for maintaining your equipment availability. You can find more detailed information and addresses on our homepage, in the [Pfeiffer Vacuum Service](#) section.

You can obtain advice on the optimal solution for you, from your [Pfeiffer Vacuum representative](#).

For fast and smooth service process handling, we recommend the following:



1. Download the up-to-date form templates.
 - [Explanations of service requests](#)
 - [Service requests](#)
 - [Contamination declaration](#)



- a) Remove and store all accessories (all external parts, such as valves, protective screens, etc.).
 - b) If necessary, drain operating fluid/lubricant.
 - c) If necessary, drain coolant.
2. Complete the service request and contamination declaration.



3. Send the forms by email, fax, or post to your local [Service Center](#).



4. You will receive an acknowledgment from Pfeiffer Vacuum.

PFEIFFER VACUUM

Submission of contaminated products

No microbiological, explosive, or radiologically contaminated products will be accepted. Where products are contaminated, or the contamination declaration is missing, Pfeiffer Vacuum will contact you before starting service work. Depending on the product and degree of pollution, **additional decontamination costs** may be incurred.

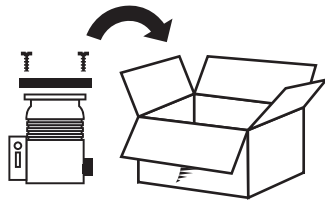

5. Prepare the product for transport in accordance with the provisions in the contamination declaration.
 - a) Neutralize the product with nitrogen or dry air.
 - b) Seal all openings with blind flanges, so that they are airtight.
 - c) Shrink-wrap the product in suitable protective foil.
 - d) Package the product in suitable, stable transport containers only.
 - e) Maintain applicable transport conditions.

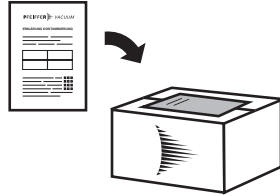

6. Attach the contamination declaration to the **outside** of the packaging.

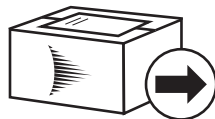

7. Now send your product to your local Service Center.

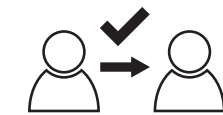

8. You will receive an acknowledgment/quotation, from Pfeiffer Vacuum.

PFEIFFER VACUUM

Our sales and delivery conditions and repair and maintenance conditions for vacuum devices and components apply to all service orders.

14 Spare parts packs

Ordering spare parts packs

- ▶ Have the vacuum pump part number to hand, along with other details from the rating plate if necessary.
- ▶ Install original spare parts only.
- ▶ When ordering the overhaul kit, observe the respective part number of the diaphragm pump.

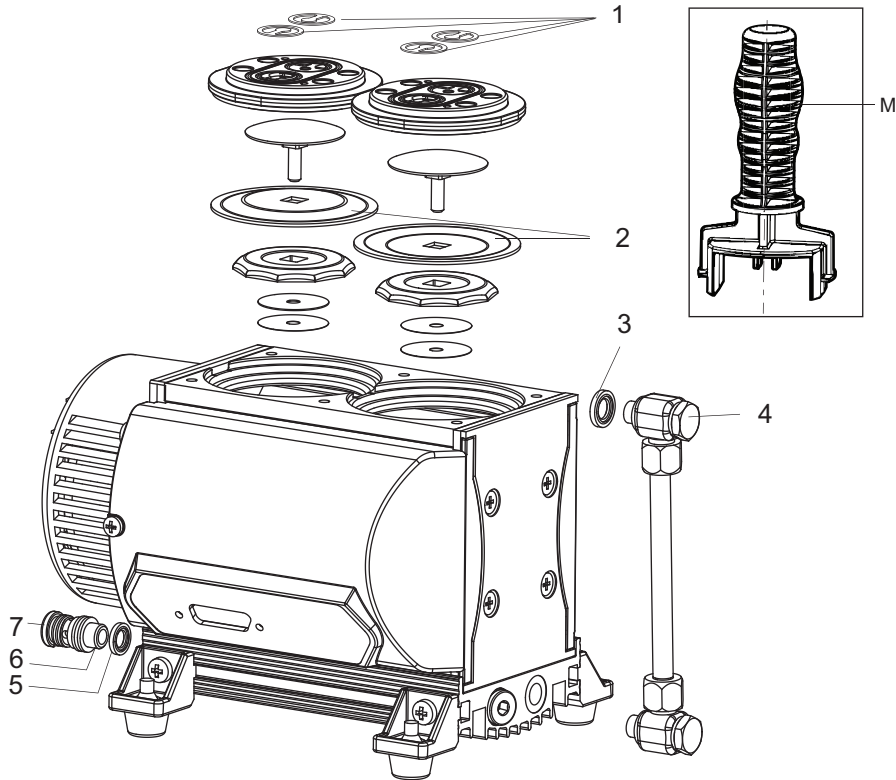

Fig. 14: Spare parts

- | | |
|----------------|-----------------|
| 1 Valves | 5 Seal |
| 2 Diaphragm | 6 Silencer |
| 3 Sealing ring | 7 Hose piece |
| 4 Banjo bolt | M Diaphragm key |

Spare parts package	Order number	comprising the following parts
Overhaul kit incl. diaphragm key	PU E22 003 -T	Pos. 1 (8×) Pos. 2 (4×) Pos. 7 (1×) Pos. M
Sealing ring	P 3529 133 -P	Pos. 3
Banjo bolt	P 0995 943	Pos. 4
Silencer incl. hose piece	P 0995 942	Pos. 6, 7
Diaphragm key	P 0995 941	Pos. M

Tbl. 22: Spare parts packs

15 Accessories

15.1 Accessory information

Display and control units

Display and operating units are used to check and adjust operating parameters.

Power packs

Power packs for fastening to the wall and standard rails or for rack assembly serve the voltage supply.

Cable and adapter

Mains, interface, connection, and extension cables provide a secure and suitable connection. Different lengths on request

Hose connections

Hose connections with adapters for connecting to a turbopump

Screwing flange

Screwing flange, including seal for the intake side of the vacuum pump

Flushing gas connection

Avoids moisture accumulating in the vacuum pump

15.2 Ordering accessories

Selection field	Order number
DCU 002, Display Control Unit	PM 061 348 AT
DCU 180, Display control unit incl. power supply pack 19"	PM C01 821
TPS 180, power supply pack for wall/standard rail fitting	PM 061 341 -T
HPU 001, Handheld Programming unit	PM 051 510 -T
Interface cable, M12 m straight/M12 m straight, 3 m	PM 061 283 -T
Connection cable with RS-485 interface for MVP to power supply pack	PM 061 350 -T
Connection cable MVP-TC-TPS, 3 m	PE 100 013 -T
USB RS-485 converter	PM 061 207 -T
Y-distributor M12 to RS-485	P 4723 010
Hose connection DN 6 x 400 mm with straight connector G 1/8" and G 1/4" including seal	P 0920 739 E
Hose connection DN 6 x 1000 mm with straight connector G 1/8" and G 1/4" including seal	P 0920 817 E
Hose DN 6; (ø 8/6 mm) polyethylene	P 0991 939
Push-in fitting G 1/8" including seal for hose connection (8/6 mm)	P 4131 029 G
Screw-in flange DN 16 ISO-KF / G 1/8" incl. seal	PK 050 108 -T
Flushing gas nozzle for MVP 020-3 / MVP 030-3	PK 050 122

Tbl. 23: Accessories

16 Technical data and dimensions

16.1 General

Basis for the technical data of Pfeiffer Vacuum diaphragm pumps:

- Specifications according to PNEUROP committee PN5
- ISO 21360:2012: "Vacuum technology - Standard methods for measuring vacuum-pump performance - General description"

The following harmonized standards are fulfilled:

- IEC 61010-1
- UL 61010-1
- CSA 61010-1

	mbar	bar	Pa	hPa	kPa	Torr mm Hg
mbar	1	$1 \cdot 10^{-3}$	100	1	0.1	0.75
bar	1000	1	$1 \cdot 10^5$	1000	100	750
Pa	0.01	$1 \cdot 10^{-5}$	1	0.01	$1 \cdot 10^{-3}$	$7.5 \cdot 10^{-3}$
hPa	1	$1 \cdot 10^{-3}$	100	1	0.1	0.75
kPa	10	0.01	1000	10	1	7.5
Torr mm Hg	1.33	$1.33 \cdot 10^{-3}$	133.32	1.33	0.133	1

1 Pa = 1 N/m²

Tbl. 24: Conversion table: Pressure units

	mbar l/s	Pa m ³ /s	sccm	Torr l/s	atm cm ³ /s
mbar l/s	1	0.1	59.2	0.75	0.987
Pa m ³ /s	10	1	592	7.5	9.87
sccm	$1.69 \cdot 10^{-2}$	$1.69 \cdot 10^{-3}$	1	$1.27 \cdot 10^{-2}$	$1.67 \cdot 10^{-2}$
Torr l/s	1.33	0.133	78.9	1	1.32
atm cm ³ /s	1.01	0.101	59.8	0.76	1

Tbl. 25: Conversion table: Units for gas throughput

16.2 Technical data

Classification	MVP 030-3 DC
Order number	PK T01 500
Flange (in)	G 1/8"
Flange (out)	G 1/8" with silencer
Pumping speed	1.8 m ³ /h
Ultimate pressure without gas ballast	≤ 2 hPa
Ultimate pressure with gas ballast	≤ 3 hPa
Intake pressure max.	1100 hPa
Exhaust pressure, max.	1100 hPa
Integral leak rate	1 Pa m ³ /s
Operating voltage: DC	24 V
Input voltage: tolerance	±10 %
Rated current absorption	1.5 A
Current max.	7,0 A
Rotation speed	600 – 2 400 rpm
I/O interfaces	RS-485

Classification	MVP 030-3 DC
Cooling method, standard	Convection cooled
Operating altitude, max.	2000 m
Protection category	IP20, NEMA Type 1 (acc. to UL 50E)
Ambient temperature	10 – 40 °C
Temperature: Storage	-10 – 60 °C
Sound pressure level	48 dB(A)
Weight	4.3 kg

Tbl. 26: Technical data, MVP 030-3 DC

16.3 Substances in contact with the media

Pump parts	Substances in contact with the media
Housing cover	Aluminum alloy (AlMgSi)
Head cover	Aluminum alloy (AlMgSi)
Diaphragm clamping disk	Aluminum alloy (AlMgSi)
Diaphragm	PTFE
Valves	FPM
Inlet	Aluminum alloy (AlMgSi)
Outlet / silencer	Aluminum / silicone rubber
Threaded hose couplings	Anodized aluminum
Hose	PE

Tbl. 27: Materials that make contact with the process media

16.4 Dimensions

Dimensions in mm

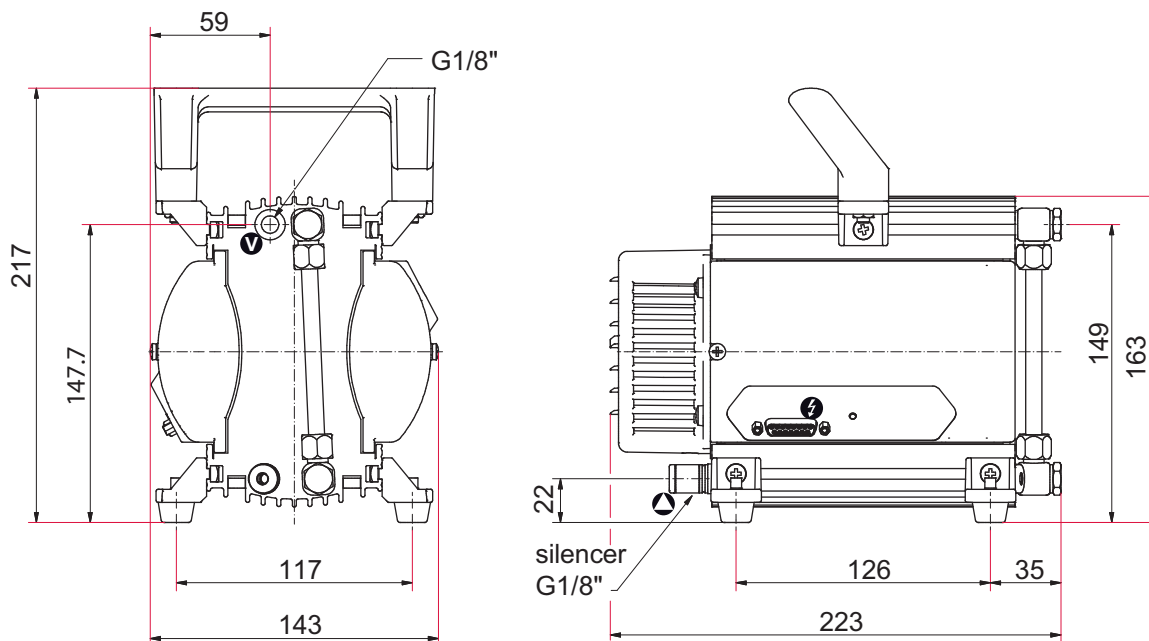

Fig. 15: Dimensions MVP 030-3 DC

Declaration of conformity

Declaration for product(s) of the type:

Diaphragm Pump

MVP 030-3 DC

We hereby declare that the listed product satisfies all relevant provisions of the following **European Directives**.

Machinery 2006/42/EC (Annex II, no. 1 A)

Electromagnetic compatibility 2014/30/EU

Restriction of the use of certain hazardous substances 2011/65/EU

Restriction of the use of certain hazardous substances, delegated directive 2015/863/EU

Harmonized standards and applied national standards and specifications:

EN ISO 12100: 2011

DIN EN 50581: 2013

EN 1012-2: 2011

EN 61010-1: 2011

EN 61326-1: 2013

EN 61010-1: 2010 (Ed. 3)

Signature:



(Daniel Sälzer)

Managing Director

Chemtech Scientific provides access to this content as a courtesy.
We do not own the content contained in this document.
All rights and credit go directly to its rightful owners.
www.chemtechscientific.com
Call us at: 484-424-9415



VACUUM SOLUTIONS FROM A SINGLE SOURCE

Pfeiffer Vacuum stands for innovative and custom vacuum solutions worldwide, technological perfection, competent advice and reliable service.

COMPLETE RANGE OF PRODUCTS

From a single component to complex systems:

We are the only supplier of vacuum technology that provides a complete product portfolio.

COMPETENCE IN THEORY AND PRACTICE

Benefit from our know-how and our portfolio of training opportunities!

We support you with your plant layout and provide first-class on-site service worldwide.

ed. D - Date 2004 - P/N:PU0076BEN



Are you looking for a
perfect vacuum solution?
Please contact us

Chemtech Scientific provides access to this content as a courtesy.
We do not own the content contained in this document.
All rights and credit go directly to its rightful owners.
www.chemtechsci.com
Call us at: 484-424-9415

