



OPERATING INSTRUCTIONS

EN

Translation of the original instructions

DUO 3 DC / DUO 3 M DC

Rotary Vane Pump

Table of contents

1	About this manual	3
	1.1 Validity	3
	1.2 Conventions	3
2	Safety	5
	2.1 Safety precautions	5
	2.2 Protective equipment	6
	2.3 Proper use	6
	2.4 Improper use	7
3	Transport and storage	8
	3.1 Transport	8
	3.2 Storage	8
4	Product description	9
	4.1 Product identification	9
	4.2 Function	10
5	Installation	11
	5.1 Set-up	11
	5.2 Connecting the vacuum side	11
	5.3 Connecting the exhaust side	12
	5.4 Voltage supply	14
	5.5 Filling up the operating fluid	14
6	Operation	16
	6.1 Before switching on	16
	6.2 Switching on	16
	6.3 Pumping condensable vapours	17
	6.4 Topping up the operating fluid	20
	6.5 Switching off	21
7	Maintenance	22
	7.1 Precautions	22
	7.2 Changing the operating fluid	24
8	Decommissioning	26
	8.1 Shutting down for longer periods	26
	8.2 Re-starting	26
	8.3 Disposal	26
9	Malfunctions	27
	9.1 Rectifying malfunctions	27
10	Service	29
11	Spare parts	30
	11.1 Spare parts packages	30
12	Accessories	33
13	Technical data and dimensions	33
	13.1 General	33
	13.2 Technical data	34
	13.3 Dimensions	35
	Declaration of conformity	36

1 About this manual

1.1 Validity

This operating manual is for customers of Pfeiffer Vacuum. It describes the functioning of the designated product and provides the most important information for safe use of the unit. The description follows applicable EU guidelines. All information provided in this operating manual refers to the current state of the product's development. The documentation remains valid as long as the customer does not make any changes to the product.

Up-to-date operating instructions can also be downloaded from www.pfeiffer-vacuum.com.

Applicable documents

DUO 3 DC / DUO 3 M DC	Operating instructions
Declaration of Conformity	Part of this document
Operating instructions for accessories (order-specifically)	see section "accessories"

*also available via www.pfeiffer-vacuum.com

1.2 Conventions

Safety instructions

The safety instructions in Pfeiffer Vacuum operating instructions are the result of risk evaluations and hazard analyses and are oriented on international certification standards as specified by UL, CSA, ANSI Z-535, SEMI S1, ISO 3864 and DIN 4844. In this document, the following hazard levels and information are considered:

DANGER
<p>Imminent danger Indicates an imminent hazardous situation that will result in death or serious injury.</p>
WARNING
<p>Possibly imminent danger Indicates an imminent hazardous situation that can result in death or serious injury.</p>
CAUTION
<p>Possibly imminent danger Indicates an imminent hazardous situation that can result in minor or moderate injury.</p>
NOTICE
<p>Command or note Command to perform an action or information about properties, the disregarding of which may result in damage to the product.</p>

Pictographs



Prohibition of an action to avoid any risk of accidents, the disregarding of which may result in serious accidents



Warning of a displayed source of danger in connection with operation of the unit or equipment



Command to perform an action or task associated with a source of danger, the disregarding of which may result in serious accidents



Important information about the product or this document

Instructions in the text

→ Work instruction: here you have to do something.

Abbreviations

M version: Version with magnetic coupling

C version: Corrosive gas version

OME: Oil mist filter

Symbols used

The following symbols are used consistently throughout in all illustrations:

- ⓪ Vacuum flange
- Ⓛ Exhaust flange
- Ⓜ Gas ballast valve
- Ⓧ Power connection

2 Safety

2.1 Safety precautions



Duty to inform

Each person involved in the installation, operation or maintenance of the vacuum pump must read and observe the safety-related parts of these operating instructions.

→ The operator is obligated to make operating personnel aware of dangers originating from the vacuum pump, the pumped medium and the entire system.



Installation and operation of accessories

Pfeiffer Vacuum pumps can be equipped with a series of adapted accessories. The installation, operation and maintenance of connected devices are described in detail in the operating instructions of the individual components.

→ For information on order numbers of components, see "Accessories".

→ Use original accessory parts only.

- Do not expose any body parts to the vacuum.
- Observe the safety and accident prevention regulations.
- Check regularly that all safety precautions are being complied with.
- Do not carry out any unauthorised modifications or conversions to the pumps.
- Depending on the operating and ambient conditions, the surface temperature of the pumps may rise above 70 °C. Use suitable finger guards if necessary.
- When returning the pumps to us please note the instructions in the Service section.

The following safety instructions are only valid for the disassembly of the drive system for a vacuum pump with a magnetic coupling:

- When disassembling the drive system from the pump housing, the strong magnetic field may influence the function and operational reliability of electrical and electronic devices.
- Persons with cardiac pacemakers must keep away from the magnetic coupling.
Danger to life!
 - **Minimum distance: 2 m!**
- Disassembled magnetic couplings must be kept away from computers, data storage media and other electronic components.
- Keep the disassembled components of the magnetic coupling separate at all times.
Danger of crushing!
- Do not allow any magnetised parts into the vicinity of the magnetic coupling. Danger of injury!

2.2 Protective equipment

Determined situations concerning the handling of vacuum pumps require wearing of personal protective equipment. The owner, respectively the employer are obligated to provide an adequate equipment to any operating persons.



DANGER

Danger to health by hazardous substances during maintenance or installation

Depending on the process vacuum pumps, components or operating fluids can be contaminated by toxic, reactive or radioactive substances.

→ Wear adequate protective equipment during maintenance and repairs or in case of reinstallation.

CAUTION

Risk of injury through hot surfaces

Vacuum pumps can become hot during operation.

→ Allow the pump to cool before maintenance and repairs.

→ If necessary wear protective gloves according to EN 420.

WARNING

Increased noise emission!

Increased noise emission can occur within a limited area surrounding the vacuum pump.

→ Provide noise protection or

→ wear hearing protection.

2.3 Proper use



NOTICE

EC conformity

The manufacturer's declaration of conformity becomes invalid if the operator modifies the original product or installs additional components.

→ Following installation into a plant and before commissioning, the operator must check the entire system for compliance with the valid EU directives and reassess it accordingly.

- The vacuum pump may only be used to generate a vacuum.
- Only use the vacuum pump for applications with oxygen concentration $\leq 21\%$.
- Installation, operating and maintenance regulations must be complied with.
- Other accessories, than those described in this manual, must not be used without the agreement of Pfeiffer Vacuum.

2.4 Improper use

Improper use will cause all claims for liability and warranties to be forfeited. Improper use is defined as usage for purposes deviating from those mentioned above, especially:

- pumping of corrosive gases
- pumping of explosive media
- operation in potentially explosive areas
- pumping of gases containing impurities such as particles, dusts and condensate; note the vapour compatibility levels of the pump
- pumping of substances that tend to sublime
- use of the vacuum pump to generate pressure
- pumping of liquids
- the use of operating fluids not specified by Pfeiffer Vacuum
- connection to pumps or units which are not suitable for this purpose according to their operating instructions
- connection to units which have exposed voltage-carrying parts

3 Transport and storage

3.1 Transport

Transport instructions

- Ensure a secure closure of the vacuum and exhaust flange during transport to prevent foreign bodies from entering the pump.

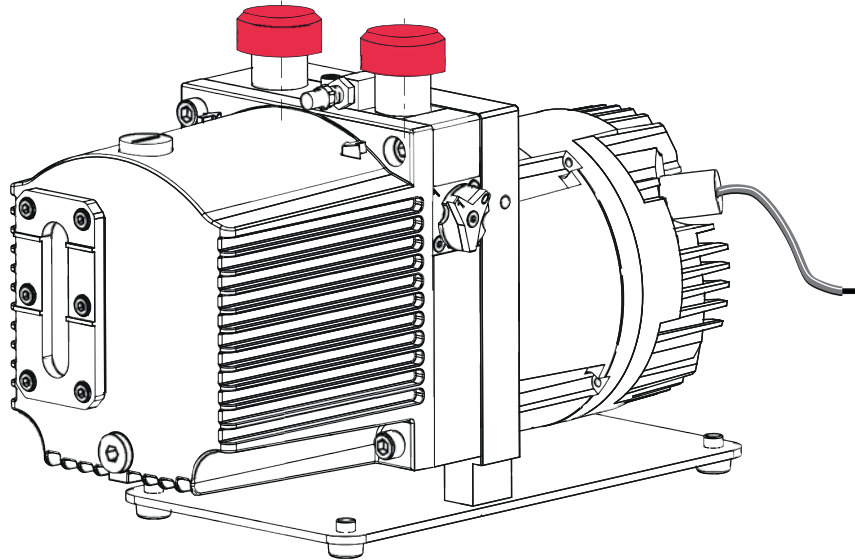

Fig. 1: Pump with locking caps

3.2 Storage

- Check that all the openings on the pump are securely closed.
- Fill up the pump with new operating fluid to the top edge of the sight glass.
- Store the pump only dry and dust-free indoors within the specified environmental conditions.
 - In rooms with moist or aggressive atmospheres, the pump must be airproof shrink-wrapped in a plastic bag together with a bag of desiccant.
 - After storage periods longer than two years, it is recommended to carry out maintenance and change the operating fluid before using the pump.

4 Product description

4.1 Product identification

To correctly identify the product when communicating with Pfeiffer Vacuum, always have the information from the rating plate available.

- Pump model and model number
- Type and amount of operating fluid
- Date of manufacture

Please find the voltage range and motor-related data on the separately attached motor rating plate.

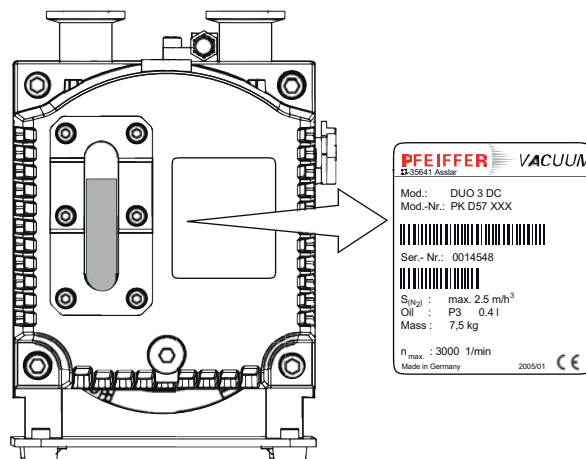

Fig. 2: Product identification on the rating plate

Scope of delivery

- Pump with drive unit
- Operating fluid (except F4 and F5)
- Cone strainer and centering ring/centering ring with nozzle with O-rings
- Locking cap for vacuum and exhaust flange
- Operating instructions

4.2 Function

Vacuum pumps of the Duo series are oil-sealed, two-stage rotary vane vacuum pumps. The vacuum pumps are equipped with a safety valve which, when the pump is at a standstill, closes the vacuum chamber vacuum tight and at the same time vents the pump.

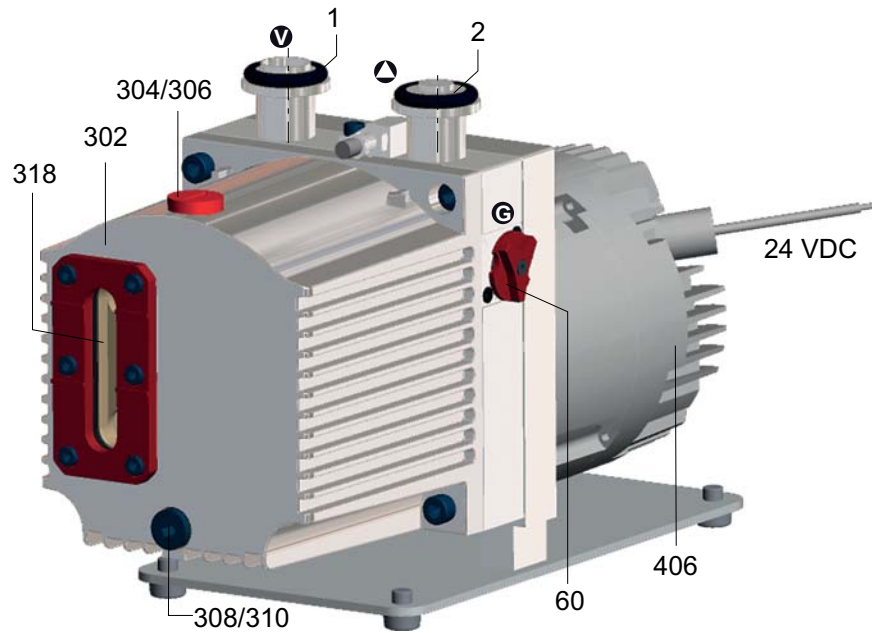

Fig. 3: DUO 3 DC / DUO 3 M DC

1	Vacuum flange	318	Sight glass	306	O-ring
2	Exhaust flange	406	Motor	310	O-ring
60	Gas ballast valve	308	Operating fluid drain screw		
302	Casing	304	Operating fluid filler screw		

5 Installation

5.1 Set-up

Installation location

Observe the following requirements when setting up the pump:

- Consider the load-bearing capacity of the installation site.
- Maximum installation altitude 2000 m (above mean sea level)
- Permissible ambient temperature: -20 ... +40 °C
- Maximum relative humidity 85%

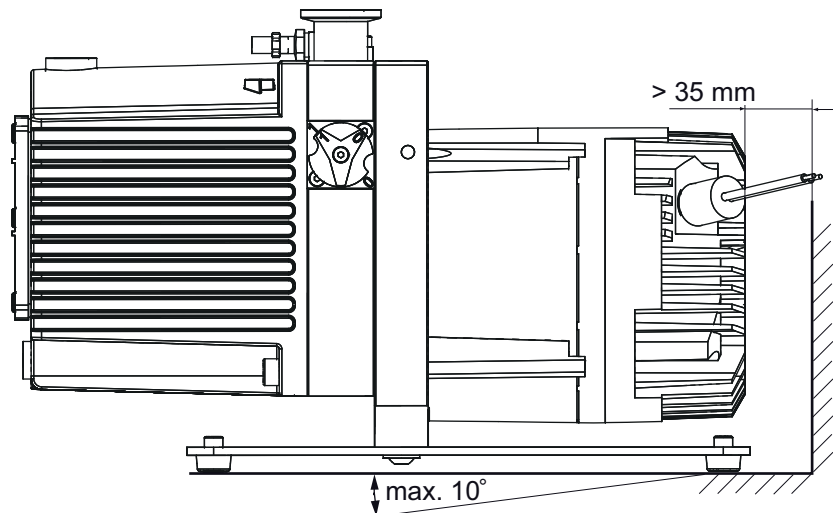

Fig. 4: Setting up the pump

- ➔ Fill up with operating fluid before operating the first time (see p. 14, chap. 5.5).
 - Amount and type according to rating plate
- ➔ Always place the pump on a firm, even surface.
- ➔ Where stationary installation is involved, anchor the pump on site.
- ➔ When installing the pump in a closed housing, ensure there is sufficient air circulation.
 - Sight glass and gas ballast valve must be visible and readily accessible.
 - Voltage and frequency information given on the motor rating plate must be visible.

5.2 Connecting the vacuum side

- ➔ Remove locking cap from the vacuum flange;
 - pay attention to the cone strainer and the respective O-ring in the intake port.
- ➔ The connection between the pump and the vacuum chamber should be kept as short as possible.
 - Depending on the pump type, use metallic hoses or PVC hoses with flange connections.
 - Separators, filters etc. may be installed upstream to protect the pump (see accessories). However, please observe the loss of pumping capacity due to the conductivity of the accessories.

5.3 Connecting the exhaust side



CAUTION

High pressure in the exhaust line!

Danger of damage to the seals and danger of the pump bursting.

- Observe the maximum permissible pressure of 1500 hPa (absolute), activate shut-off valves in such a way that they open before or at the same time as the pump is started.



NOTICE

Reduced pressure in the exhaust line!

Reduced pressure in the exhaust line can cause malfunctions and damage the pump. It is only allowed in pumps with magnetic coupling.

- Ensure that when discharging gases the exhaust pressure is at least 250 hPa higher than the suction pressure.

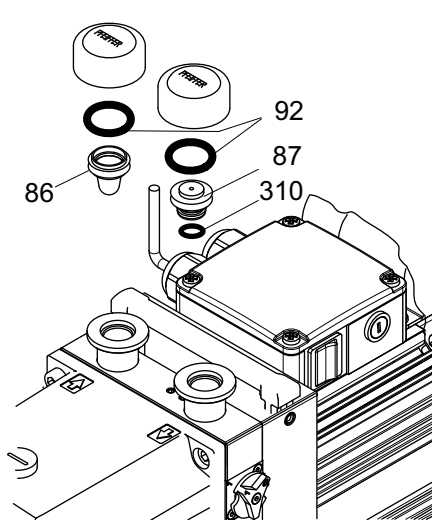

- 86 Cone strainer
- 87 Centering ring with nozzle
- 92 O-ring
- 310 O-ring

- Before attaching the piping at the exhaust flange remove locking cap and insert centering ring/centering ring with nozzle with the respective O-rings.
- Choose the cross-section of the exhaust line to be at least the size of the nominal connection diameter of the vacuum pump's exhaust connection.
- Piping to the pump must be suspended or supported.
 - Physical forces from the piping system must not be allowed to act on vacuum pumps.
- Lay piping from the pump sloping downward so that no condensate can flow back into the pump; otherwise fit a condensate separator.
 - If an air trap is created in the system, then a device for draining condensation water must be provided at the lowest point.



WARNING

Emission of toxic substances from the exhaust!

Danger of poisoning from emitted gases or vapours, which can be detrimental to health and/or can pollute the environment, depending on the particular application.

- Comply with the applicable regulations when working with toxic substances.
- Only officially approved filter systems may be used to separate and remove these substances.

Fitting the OME and the oil return line (option)

- Turn off the vacuum pump, vent to atmospheric pressure and allow to cool.
- Remove the protective cap from the connection flange.
- Zentrierring mit Düse 87 durch einen Standard-Zentrierring (DN 16 ISO-KF) ersetzen.
- Place OME on the exhaust side of the pump with flange pointing downwards and fit with clamping ring (accessories), pay attention to centering ring.

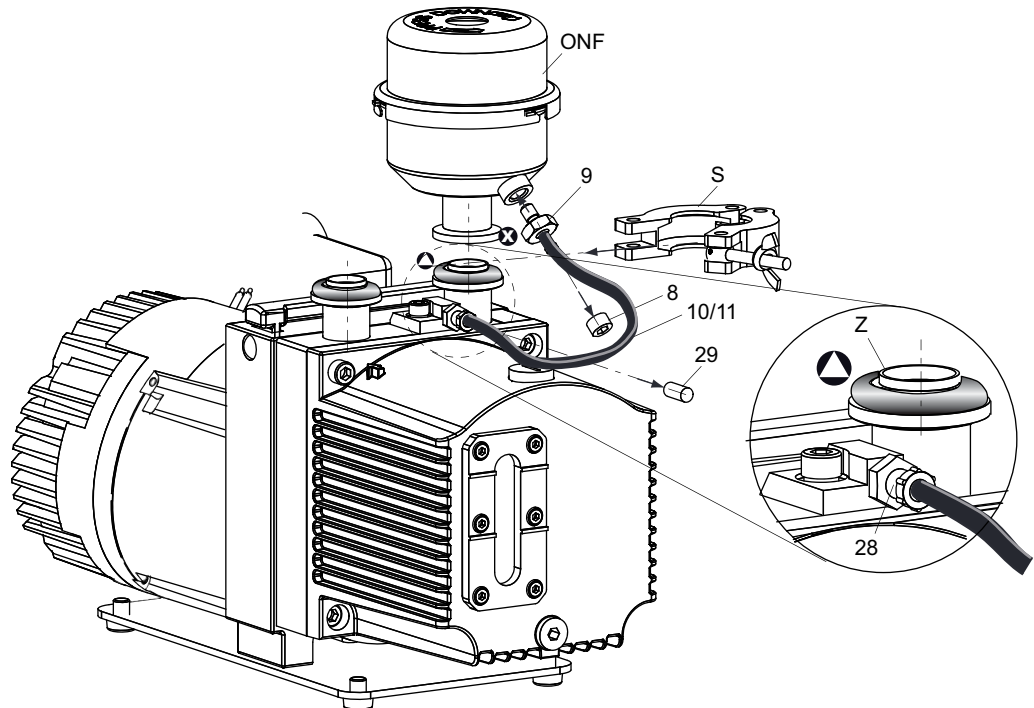

Fig. 5: DUO 3 DC with operating fluid return line

8	Locking screw	11	Spring (inside the hose)	S	Clamping ring
9	Fitting	28	Fitting	Z	Centering ring
10	Operating fluid return hose	29	Locking cap		

Note: As the hexagon socket of the **locking screw** is not metric, a **special spanner (3/16")** (provided as part of the scope of supply) is required.

- Unscrew locking screw 8.
- Drain off operating fluid if so and fill in the pump.
- Screw in fitting 9 in place of the locking screw 8; take care with seal ring.
- Loosen fitting 28 and take off locking cap 29.
- Insert spring 11 into hose 10 (anti-kink device).
- Fit operating fluid return hose 10 at both sides,
 - keep the hose as short as possible and protect it from bending.
- Tighten the union nuts of both screw fittings.

5.4 Voltage supply



NOTICE

Incorrect polarity!

Risk of destroying the equipment when connecting the power supply.

→ Note the color markings on the wires when connecting the pump cable.

Connecting the direct current motor

→ Connect +24 V DC power supply (in accordance with type plate) to the corresponding cable leads.

Assignment	Lead colour of the connection cable
+ 24 V DC	black/white
GND (0 V)	brown/white

Motor protection



Overload protection of the motor

If the pump is blocked, the motor electronics automatically shut down the pump.

→ Reset by switching off the supply voltage for at least 30 s after motor standstill.

5.5 Filling up the operating fluid

The type and amount of operating fluid should be visible on the pump's rating plate for every rotary vane pump.

Permissible operating fluid

- Inland 45 (standard operating fluid)
- Operating fluid for special applications on request



NOTICE

Use approved operating fluids only!

The use of operating fluids that have not been approved by Pfeiffer Vacuum shall result in a limited warranty. In such cases, it is not possible to guarantee that product-specific performance data will be achieved.

→ Prior consultation is required before using other application-specific operating fluids.

Filling up the operating fluid

- Unscrew operating fluid filler screw 304.
- Fill up the operating fluid.
 - First fill when the pump is cold: Maximum 3/4 of the min./max. range.
- Screw in operating fluid filler screw 304.

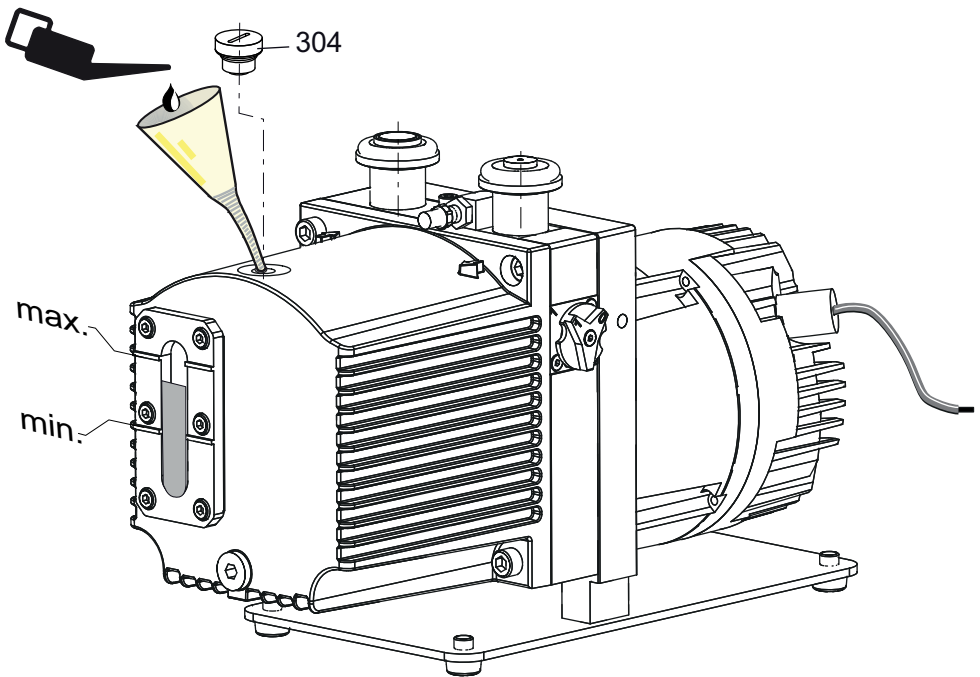

Fig. 6: Filling up the operating fluid

6 Operation

6.1 Before switching on

- Check the operating fluid level in the sight glass.
- Compare the voltage information on the rating plate with the supply voltage.
- Check that the exhaust connection allows free flow (max. permissible pressure 1500 hPa absolute).
 - Activate the shut-off valves in such a way that they open before or at the same time as the pump is started.
- Protect the pump sufficiently from taking in contaminants by means of suitable precautions (e.g. dust filters); if necessary, check operating fluid regularly or replace at shorter intervals.

6.2 Switching on

The pump can be switched on in any pressure range between atmospheric and ultimate pressure.

The ideal operating condition of the pump is achieved during continuous operation. Cyclic operation is possible, but 10 cycles per hour should not be exceeded and the operating phase should always be longer than the downtime (non-operation time).

No special precautions are necessary when pumping dry gases. In order to attain the lowest possible ultimate pressures, the gas ballast valve should be closed.



CAUTION

Hot surface!

Danger of burns if hot parts are touched. Depending on the operating and ambient conditions, the surface temperature of the pump may rise above 70 °C.

→ In this case, use suitable finger guards.

- Switch on the pump with the vacuum flange closed and allow to warm up for 30 minutes.
- Check operating fluid level only when the pump is warm and running; therefore
 - close vacuum flange and gas ballast valve,
 - correct filling level during operations: within the markings at the sight glass frame,
 - check operating fluid daily in non-stop operation, otherwise whenever the pump is switched on. Refilling is possible when the pump is in final vacuum operation.

Temperature monitoring

To protect the motor against overloading, a temperature sensor is built into the electronic output stage, which measures the temperature of the printed circuit board (PCB) and switches the controller off at approx. 110 °C. To return the drive to service after the over-temperature cut-off, the error must be acknowledged either by switching the digital inputs in the mode "stop with freewheel" or must be short-time disconnected from the logic power supply.

6.3 Pumping condensable vapours

Should the process gases contain condensable gases, the rotary vane pump must be operated with gas ballast (i.e. with an open gas ballast valve).



NOTICE

Bad final vacuum and damage to the pump!

Danger of condensation and corrosion due to exceeding the water vapour compatibility during operation without gas ballast or in case of insufficient supply of flushing gas.

- Only pump vapours when the pump is warm and the gas ballast valve is open.
- When the process has been completed, allow the pump to continue running for about 30 minutes with the vacuum flange closed and the gas ballast open for operating fluid regeneration purposes.

Gas ballast valve, standard version

To avoid condensation in the pump when pumping condensable vapours, air is periodically fed into the working chamber at the beginning of the compression phase via the gas ballast valve 60.

The gas ballast valve is closed when turning to the right to position 0 and open when turning to the left to position 1. Intermediate settings are not possible.

The gas ballast valve 60 will only be contaminated when airborne dust is in the intake air.

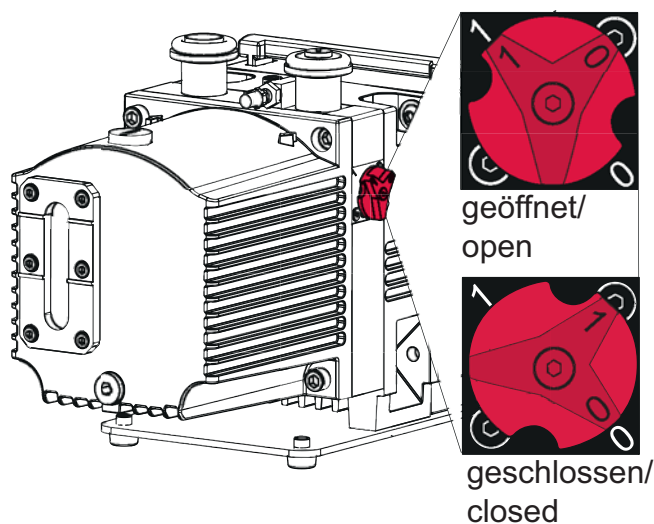

Fig. 7: Standard version 60 of gas ballast valve

Operation with accessories

Gas ballast valve, corrosive gas version

If the pumping process requires the connection of flushing gas, the C version of the gas ballast valve with the flushing gas connection must be used.

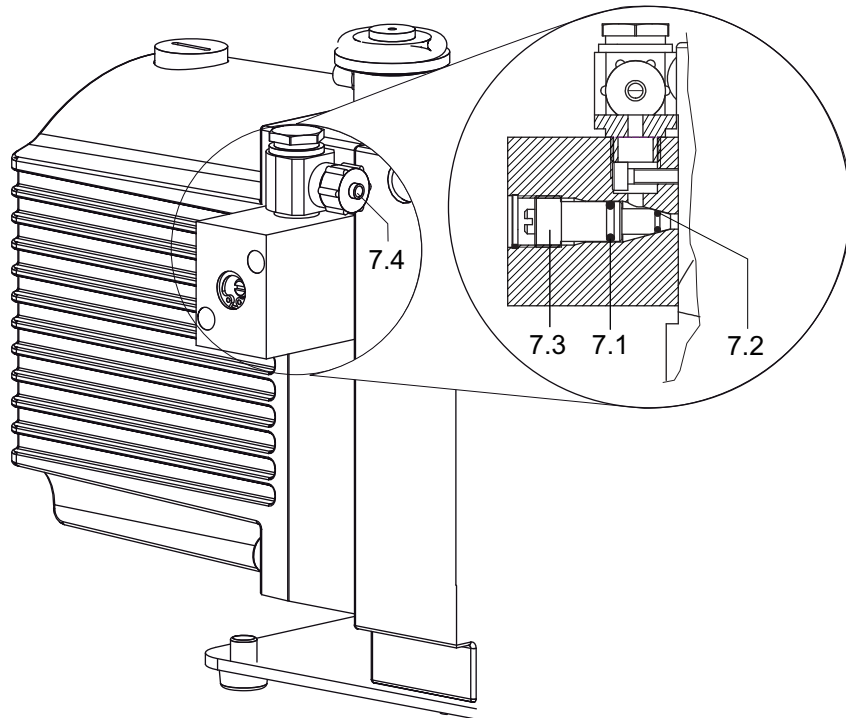

Fig. 8: Corrosive gas version of gas ballast valve

- | | |
|------------|--|
| 7.1 O-ring | 7.3 Proportioning screw |
| 7.2 O-ring | 7.4 Flushing gas connection (for DN 6 mm hose) |

- Connect flushing gas at the flushing gas connection 7.4.
- Set flushing gas pressure; maximum pressure 1500 hPa (absolute).
 - Select the type and amount of flushing gas depending on the process; consult Pfeiffer Vacuum if necessary.
- Use the proportioning screw 7.3 to set the desired amount of gas.
 - Closed when fully turned to the right; open when fully turned to the left.

Gas ballast valve with solenoid valve

To control the flow of the flushing gas externally, an electromagnetic valve can also be used as an alternative to the versions described above. The valve makes it easier to operate the gas ballast and allows clean air or other gas to be let in in a process-controlled manner.



NOTICE

Flushing gas pressure higher than allowed endangers the operational reliability of the pump.

The power input of the pump, the temperature and the ejection of operating fluid will increase.

- Observe the maximum permissible flushing gas pressure of 1500 hPa (absolute).
- Set the amount of flushing gas on site; dosing is not possible when using a solenoid valve!

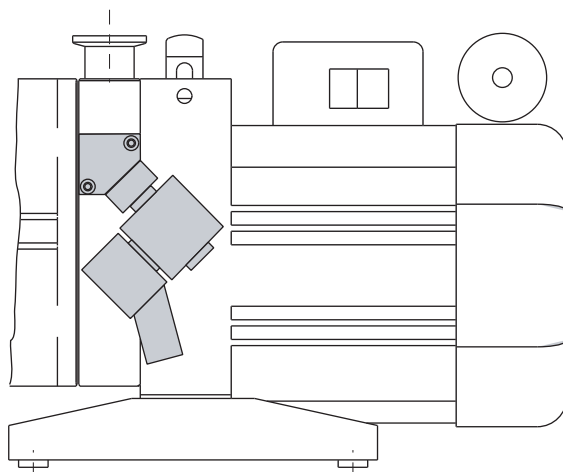

Fig. 9: Assembling the solenoid valve at the gas ballast inlet

Performance data of the solenoid valve	
2/2 way valve	closed when disconnected
Supply voltage	24 V DC, +/- 10 %
Power input	4 W
Socket	Type 2506
Threaded connection of flushing gas	1/8" inside
Flushing gas pressure	max. 1500 hPa (absolute)
Amount of flushing gas	max. 180 l/h

6.4 Topping up the operating fluid

If the operating fluid has reached its minimum filling level, the operating fluid must be topped up. The fluid can be topped up during operation in the final vacuum.

Filling up the operating fluid

- Unscrew operating fluid filler screw 304.
- When the pump is at operation temperature, top up the operating fluid up to the "max." marking.

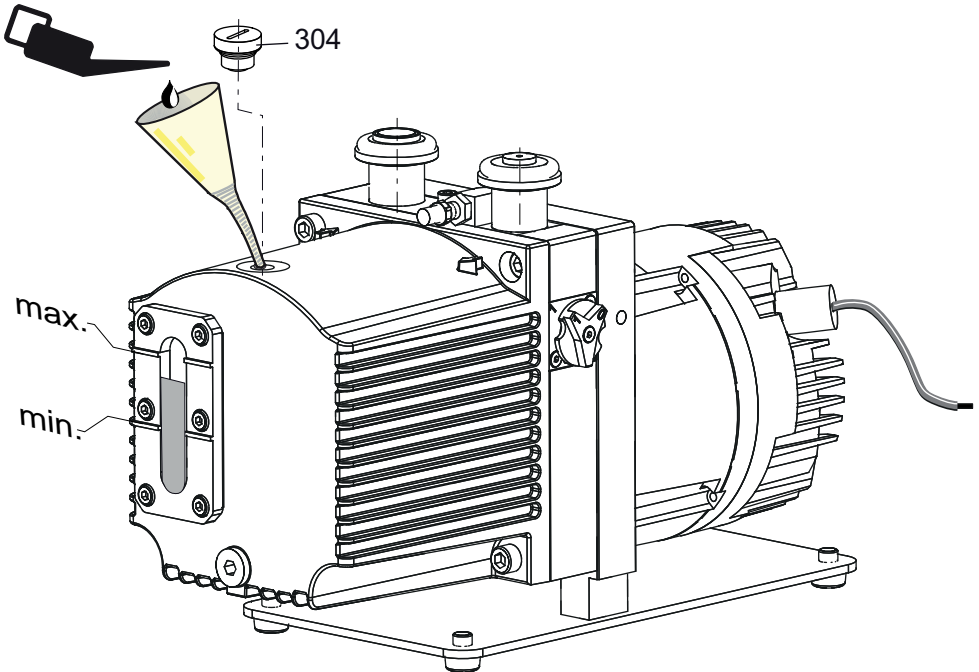

Fig. 10: Filling up the operating fluid

- Screw in operating fluid filler screw 304.

6.5 Switching off

The pump can be switched off in any pressure range.

Rotary vane pumps have an integrated safety valve on the intake side. If the differential pressure between the exhaust side and the intake side is ≥ 250 hPa, then the valve closes automatically and vents the pump when the pump is switched off.

→ Switch off the pump.

Venting the vacuum chamber



NOTICE

Danger of backflow of operating fluid into the intake line!

Contamination of the connected vacuum system!

- Vent the vacuum chamber within 30 s, regardless of the chamber size.
- For a longer venting process, use an additional shut-off valve and shut off the intake line after switching off the pump.

Maintaining the vacuum in the chamber



NOTICE

Danger of backflow of operating fluid into the intake line!

Contamination of the connected vacuum system!

- Because the safety valve of the pump is not suitable for longer-term sealing, install an additional shut-off valve in the intake line.
- Shut off the intake line immediately after switching off the pump.

7 Maintenance

7.1 Precautions



WARNING
<p>Danger of injury from moving parts! After power failure or motor shutdown due to overheating, the motor may restart automatically.</p> <ul style="list-style-type: none"> → Secure the motor so that it cannot be switched on while any work is being performed on the pump. → If necessary, dismantle the pump from the installation for inspection.



WARNING
<p>Pump parts may be contaminated from pumped media! Danger of poisoning due to contact with harmful substances.</p> <ul style="list-style-type: none"> → Decontaminate the pump before carrying out any maintenance work. → In the event of contamination, take suitable safety precautions to prevent your health from being harmed by any dangerous substances.

- Turn off the vacuum pump, vent to atmospheric pressure and allow to cool.
- Disconnect the drive motor from the mains and secure it so that it cannot be switched on.
- Only dismantle the pump as far as necessary to carry out maintenance.
- Dispose of used operating fluid in compliance with local regulations.
- When using synthetic operating fluids or working with toxic substances or substances contaminated with corrosive gases, the relevant instructions governing their use must be observed.
- Use only alcohol or similar agents for cleaning pump parts.

Magnetic coupling

The following safety instructions are only valid for the **disassembly** of the drive system for vacuum pumps with **magnetic coupling!**



DANGER
<p>Strong magnetic field in the vicinity of the drive system! Danger to life for persons with cardiac pacemakers when the drive system is disassembled.</p> <ul style="list-style-type: none"> → Persons with cardiac pacemakers must not enter the area ($\leq 2\text{m}$) of the magnetic field. → Rooms in which open couplings are accessible must be identified: "No trespassing for persons with heart pacemaker"! → Disassembled magnetic couplings must be kept away from computers, data storage media and other electronic components.

Checklist for inspection, maintenance and overhaul

Certain maintenance and overhaul work should only be performed by Pfeiffer Vacuum Service (PV). Pfeiffer Vacuum will be released from all warranty and liability claims if the required, below listed, intervals are exceeded or maintenance or overhaul procedures are not performed properly. This also applies if replacement parts other than Pfeiffer Vacuum OEM replacement parts are used.

Activity	K//W/R ¹	daily	as required; at least annually	as required; at least every 2 years	as required; at least every 4 years
Check operating fluid level	K	X			
Visual inspection (leak-tightness/oil leaks)	K	X			
Check filter insert of external oil mist filter (if existent)	K	X			
Change operating fluid	I		X		
Disassemble casing, sight glass and pumping system and clean casing outside (without cleaning agent)	I		X		
Clean gas ballast valve and silencer	I		X		
Clean the motor fan cap	I		X		
Disassemble the pump, clean and exchange seals and wearing parts: ⇒ Radial shaft seal ring ⇒ Coupling half at motor side ⇒ Hydraulic valve ⇒ Exhaust valve tongue ⇒ Valve flap of the gas ballast valve ⇒ Vane springs	W			X (PV)	
Carry out work in accordance the maintenance and additionally: ⇒ Change vanes ⇒ Change valves, springs and sight glass ⇒ Change silencer nozzle ⇒ Check coupling and exchange if necessary	R				X (PV)

Depending on the process, the required replacement intervals for the operating fluid and the intervals for inspection, maintenance and overhaul may be shorter than the guide values specified in the table. Consult Pfeiffer Vacuum Service, if necessary.

1. K: Checking, I: Inspection, W: Maintenance, R: Overhaul

7.2 Changing the operating fluid

The service life of the operating fluid is dependent on the application area for the pump. It must be changed if:

- The specified ultimate pressure is no longer reached
- The operating fluid in the sight glass is visibly contaminated, milky, or cloudy
- The operating fluid is thermally aged, identifiable by its color ID value (applies to mineral oils only).



Depending on the applications, Pfeiffer Vacuum recommends determining the exact service life of the operating fluid during the first year of operation.

The replacement interval may vary from the guide value specified by Pfeiffer Vacuum depending on the thermal and chemical loads, and the accumulation of suspended particles and condensation in the operating fluid.



WARNING

Hot operating fluid!

Danger of burns when draining due to contact with skin.

- Wear suitable protective clothing.
- Use a suitable collecting vessel.



WARNING

Operating fluid may contain toxic substances from the pumped media!

Danger of poisoning from the emission of harmful substances from the operating fluid.

- Wear suitable protective clothing and respirators.
- Dispose of operating fluid according to the local regulations



Request safety data sheets for operating fluids and lubricants

from Pfeiffer Vacuum or download at www.pfeiffer-vacuum.com.

- Dispose of operating fluid according to the local regulations.

Draining the operating fluid

- Turn off the vacuum pump, vent to atmospheric pressure and allow to cool.
- Unscrew operating fluid filler screw 304.
- Place a collecting vessel under the drain hole.
- Unscrew operating fluid drain screw 308.
- Drain the operating fluid while still quite hot;
 - to empty the pump fully, tip it forward slightly.

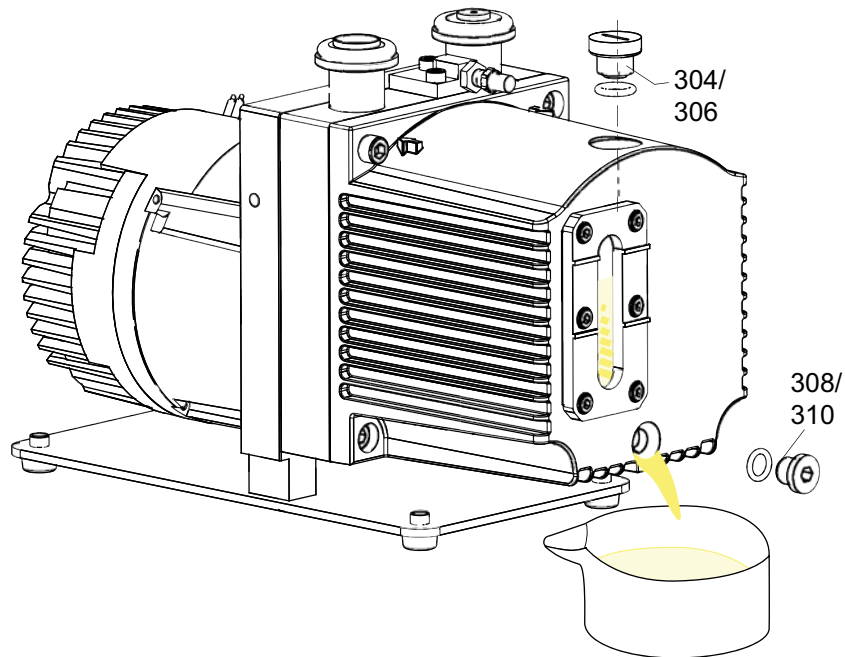

Fig. 11: Draining the operating fluid

- Screw in operating fluid drain screw 308; pay attention to O-ring.
- Screw in operating fluid filler screw 304.
- Allow pump to run for a maximum of 5 seconds with the vacuum flange open.
- Drain off remaining operating fluid.
 - In case of serious contamination, the operating fluid will have to be changed several times (flushing):
- Fill up with operating fluid and check the filling level (*see p. 14, chap. 5.5*).

Flushing and cleaning

If the interior of the pump is heavily contaminated with process residues, we recommend performing several changes of operating fluid to flush away the contamination:

- Operate the pump with the gas ballast open until the pump has warmed up.
- Drain the operating fluid again and check for contamination, flush again if necessary.
- Take off the cap and clean the sight glass and pump system externally (without cleaning agent).
- Replace the filter elements in the accessories.
- Screw the operating fluid drain screw back in.
- Fill up with operating fluid and check the filling level (*see p. 14, chap. 5.5*).
- Screw in operating fluid filler screw 304.

8 Decommissioning

8.1 Shutting down for longer periods

Before shutting down the pump, observe the following procedure and adequately protect the pump system against corrosion:

- Switch off pump.
- Change operating fluid.
- Start the pump and allow the pump to warm up.
- Switch off the pump.
- Fill up the pump with new operating fluid to the top edge of the sight glass.
- Close vacuum flange and exhaust flange with locking caps.
- Store the pump only dry and dust-free indoors within the specified environmental conditions.
 - In rooms with moist or aggressive atmospheres, the pump must be airproof shrink-wrapped in a plastic bag together with a bag of desiccant.
 - After storage periods longer than two years, it is recommended to carry out maintenance and change the operating fluid before using the pump.
- Do not store pump in the vicinity of machines, lanes, etc., because strong vibrations can damage the rotor bearings.

8.2 Re-starting



Emission of operating fluid!

Danger of the operating fluid being emitted at the exhaust flange if overfilled.

- Drain the operating fluid to the normal level before restarting the pump.



NOTICE

Re-starting

The serviceability of the operating fluid without operation is a maximum of 2 years. Before restarting after a shut-down of **2 years or longer**, carry out the following work.

- Replace the operating fluid.
- Replace the radial shaft sealing rings and further elastomer parts.
- Replace bearings at pumps with anti-friction bearings.
- Follow the maintenance instructions and inform Pfeiffer Vacuum.

8.3 Disposal

Products or parts thereof (mechanical and electrical components, operating fluids, etc.) may cause environmental burden.

- Safely dispose of the materials according to the locally applicable regulations.

9 Malfunctions

Please note the following instructions should the pump malfunction:



CAUTION

Hot surface!

Danger of burns if hot parts are touched. The surface temperature of the pump may rise above 105 °C in case of malfunction.

→ Carry out work on the pump only after it has cooled to a safe temperature.

9.1 Rectifying malfunctions

Problem	Possible causes	Remedy
Pump will not start up	No operating voltage or voltage does not correspond to the motor data	Check operating voltage
	Pump temperature too low	Warm up pump to
	Thermal protection switch has responded	Detect and fix cause of overheating; allow pump to cool off if necessary.
	Pump system dirty	Clean pump; contact Pfeiffer Vacuum Service if necessary.
	Pump system damaged	Clean and overhaul pump; contact Pfeiffer Vacuum Service if necessary.
	Motor defective	Replace motor
Pump switches off after a while after being started	Thermal protection switch of the motor has responded	Detect and fix cause of overheating; allow motor to cool off if necessary.
	Mains fuse protection triggered due to overload (e.g. cold start)	Warm up pump
	Exhaust pressure too high	Check opening of exhaust line and exhaust accessories
Pump does not attain ultimate pressure	Measurement reading is false	Check gauge, check ultimate pressure without installation connected.
	Pump or connected accessories are dirty	Clean pump and check components for contamination.
	Operating fluid dirty	Operate pump for a longer period with gas ballast valve open or change operating fluid
	Leak in system	Repair leak
	Operating fluid filling level too low	Top off operating fluid
	Pump damaged	Contact Pfeiffer Vacuum Service.
Pumping speed of pump too low	Intake line not well-dimensioned	Keep connections as short as possible and ensure that cross-sections are sufficiently dimensioned
	Exhaust pressure too high	Check opening of exhaust line and exhaust accessories
Loss of operating fluid	Swivel gasket leaky	Check tightness; replace gasket if necessary
	Radial shaft seal ring leaky	Replace seal ring and check bushing
	Operational loss of operating fluid	If necessary, install oil mist filter and oil return unit
Unusual operating noises	Silencer dirty	Clean or replace the silencer.
	Damage to the pump system	Clean and overhaul pump; contact Pfeiffer Vacuum Service if necessary.
	Motor bearing defective	Replace motor; contact Pfeiffer Vacuum Service if necessary



NOTICE

Service work should be carried out by a qualified person only!

Pfeiffer Vacuum is not liable for any damage to the pump resulting from work carried out improperly.

- Take advantage of our service training programs; additional information at www.pfeiffer-vacuum.com.
- Please state all the information on the pump rating plate when ordering spare parts.

10 Service

Pfeiffer Vacuum offers first-class service!

- Maintenance/repairs on site by Pfeiffer Vacuum field service
- Maintenance/repairs in a nearby service center or service point
- Fast replacement with exchange products in mint condition
- Advice on the most cost-efficient and quickest solution

Detailed information and addresses at: www.pfeiffer-vacuum.com (Service).

Maintenance and repairs in Pfeiffer Vacuum ServiceCenter

The following steps are necessary to ensure a fast, smooth servicing process:

- Download the forms "Service Request" and "Declaration on Contamination".¹⁾
- Fill out the "Service Request" form and send it by fax or e-mail to your Pfeiffer Vacuum service address.
- Include the confirmation on the service request from Pfeiffer Vacuum with your shipment.
- Fill in the contamination declaration and enclose it in the shipment (required!).
- Dismantle all accessories.
- Drain operating fluid/lubricant.
- Drain cooling medium, if used.
- Send the pump or unit in its original packaging if possible.

Sending of contaminated pumps or devices

No units will be accepted if they are contaminated with micro-biological, explosive or radioactive substances. "Hazardous substances" are substances and compounds in accordance with the hazardous goods directive (current version). If pumps are contaminated or the declaration on contamination is missing, Pfeiffer Vacuum performs decontamination at the shipper's expense.

- Neutralise the pump by flushing it with nitrogen or dry air.
- Close all openings airtight.
- Seal the pump or unit in suitable protective film.
- Return the pump/unit only in a suitable and sturdy transport container and send it in while following applicable transport conditions.

Service orders

All service orders are carried out exclusively according to our repair conditions for vacuum units and components.

¹⁾ Forms under www.pfeiffer-vacuum.com

11 Spare parts

11.1 Spare parts packages

Spare parts are linked to the article no. of the pump, therefore please state all information on the rating plate when ordering spare parts. Other spare parts than those described in this manual must not be used without the agreement of Pfeiffer Vacuum.

Set of radial shaft seal ring (RSSR)

- RSSR and felt ring
- Coupling, motor side

Set of coupling for pump with magnetic coupling

- Can
- Coupling half, drive side
- Coupling half, pump side

Maintenance kit and set of seals

The kit contains all the **critical wearing parts** that should be replaced after disassembly and cleaning the pump.

- Set of seals with all seals (O-rings) of the assembly groups and the subassemblies
- Radial shaft seal ring, coupling and felt ring
- Wearing parts pumping system
- Wearing parts vacuum safety valve

Set of vanes

- Vanes
- Vane springs

Overhaul kit and set of seals

The kit contains all the wearing parts that should be replaced after disassembly and cleaning the pump:

- Set of seals with all seals (O-rings) of the assembly groups and the subassemblies
- Wearing parts of the pumping system (incl. vanes and springs)
- Wearing parts of the valves
- Coupling spider.

Spare parts package	No.	consisting of
Radial shaft ring kit incl. motor coupling	PK E06 103 -T	27, 42, 44, 306, 310, 312.
Coupling kit, M version	PK E06 014 -T	44, 46, 47, 48, 50, 51, 52, 54, 56, 58.
Maintenance kit+ set of seals, standard	PK E01 047 -T	38, 42, 44, 45, 74, 120, 124, 216 + 27, 40, 92, 204, 206, 208, 306, 310, 312, 314.
Maintenance kit+ set of seals, M version	PK E01 041 AT	38, 74, 120, 124, 216 + 27, 29, 40, 50, 63, 78, 92, 204, 206, 208, 306, 310, 312, 314.
Set of vanes	PK E08 030 -T	118, 120, 122.
Overhaul kit+set of seals, standard	PK E02 048 -T	38, 42, 44, 45, 74, 108, 109, 118, 120, 122, 124, 126, 212, 214, 216, 218, 304, 316 + 27, 29, 40, 92, 204, 206, 208, 306, 310, 312, 314.
Overhaul kit+set of seals, M version	PK E02 049 AT	38, 74, 108, 109, 118, 120, 122, 124, 126, 212, 214, 216, 218, 304, 316 + 27, 29, 40, 50, 63, 78, 92, 204, 206, 208, 306, 310, 312, 314.

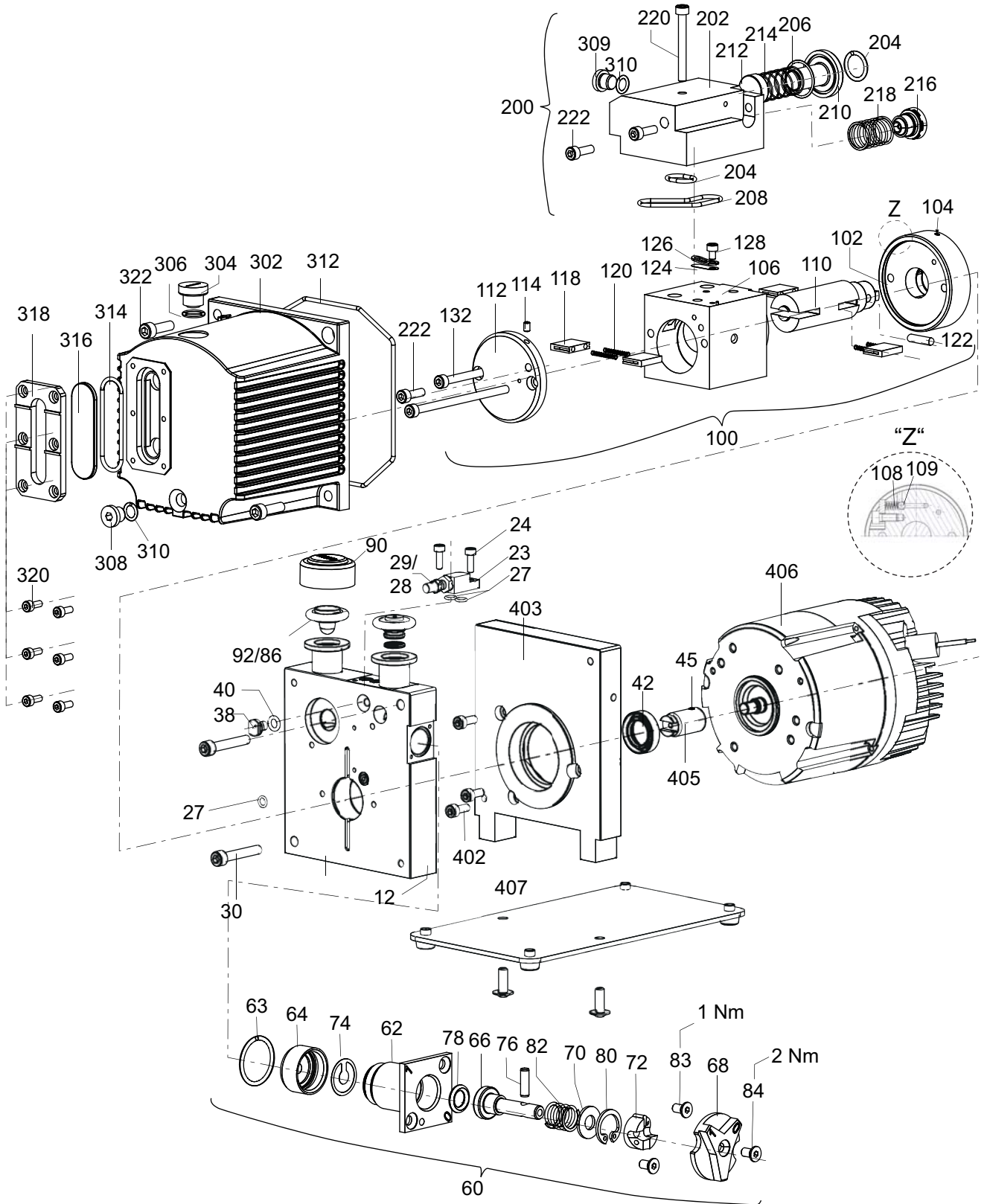

Fig. 12: Exploded view DUO 3 DC / DUO 3 M DC

Spare parts

12	Support stand	84	Countersunk screw	208	O-ring
23	Connection operating fluid return line	86	Centering ring with cone strainer	210	Valve seat
24	Cylinder head screw	90	Locking cap	212	Valve plate
27	O-ring	92	O-ring	214	Compression spring
28	Fitting	100	Pumping system, complete	216	Hydraulic valve
29	Cap	102	Support plate	222	Cylinder head screw
30	Cylinder head screw	104	Nozzle	218	Compression spring
32	Cylinder head screw	106	Cylinder	220	Cylinder head screw
38	Silencer	108	Compression spring	302	Casing
40	O-ring	109	Ball	304	Operating fluid filler screw
42	Radial shaft seal ring	110	Rotor	306	O-ring
45	Set screw	112	Bearing cover	308	Operating fluid drain screw
60	Gas ballast valve, complete	114	Stud screw	309	Locking screw
62	Flange housing	116	Cylinder head screw	310	O-ring
63	O-ring	118	Vane	312	O-ring
64	Screw cap	120	Compression spring	314	O-ring
66	Tappet	122	Hydraulic vane	316	Sight glass
68	Knob	124	Valve plate	318	Sight glass frame
70	Washer	126	Valve trap	320	Cylinder head screw
72	Camp plate	128	Cylinder head screw	322	Cylinder head screw
74	Valve tongue	130	Dowel pin	402	Cylinder head screw
76	Cylinder pin	132	Cylinder head screw	403	Motor intermediate flange
78	O-ring	200	Vacuum safety valve, complete	405	Coupling, motor side
80	Circlip	202	Valve housing	406	Motor
82	Compression spring	204	O-ring	407	O-ring
83	Countersunk screw	206	O-ring		

Magnetic coupling

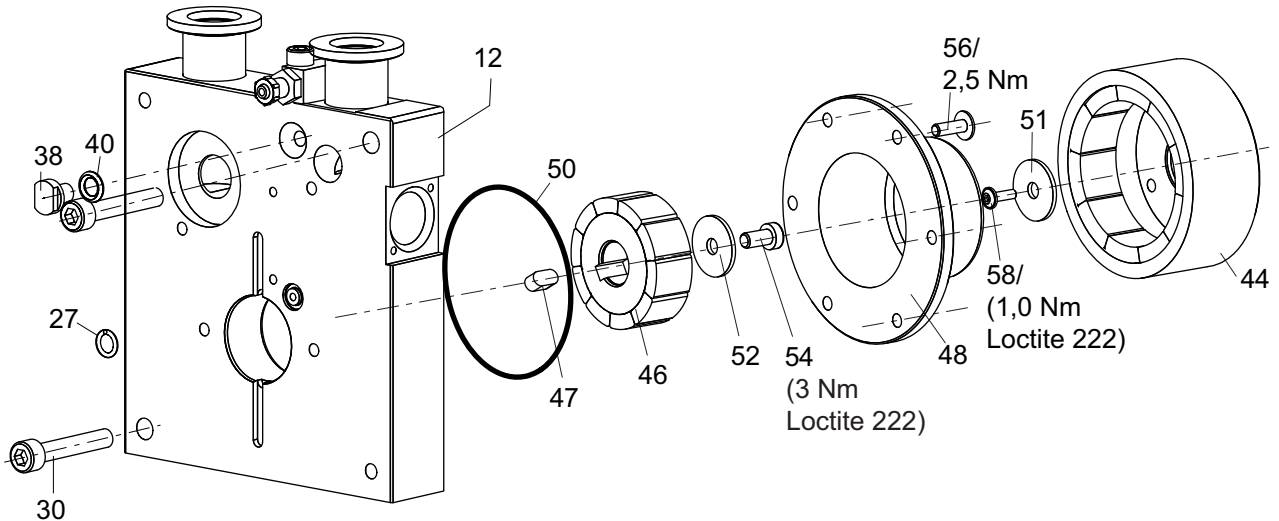

Fig. 13: DUO 3 M DC

12	Support stand	44	Magnetic coupling, drive side	51	Disk
27	O-ring	46	Magnetic coupling, pump side	52	Disk
30	Cylinder head screw	47	Key	54	Screw
38	Silencer	48	Can	56	Screw
40	O-ring	50	O-ring	58	Screw

12 Accessories

Designation	Duo 3 DC, Duo 3 M DC
TPS 310, mains pack for wall/standard rail fitting	PM 061 342 -T
Connecting plug TPS 110/180/310/400 DC out	P 4723 102
SAS 16, dust separator, DN 16 ISO-KF, polyester filter	PK Z60 506
KAS 16, condensate separator for pumping speeds from 1.6 to 12 m ³ /h	PK Z10 003
OME 16 S, oil mist filter for pumping speeds up to 12 m ³ /h	PK Z40 000
Oil return unit from OME 16 S to Duo 1.6 / Duo 3	PK 005 986 -T
OME 16 M, oil mist filter for pumping speeds of up to 12 m ³ /h	PK Z40 003
Oil return unit from OME 16 M to Duo 1.6, 3, 6, 11	PK 006 080 -T
ZFO 16, zeolite trap	PK Z70 003
Operations monitoring unit 3 for Duo 1.6/3/6/11 and Duo 5/10/20 M	PK 196 146 -T
Operations monitoring unit 2 for Duo 1.6/3/6/11 and Duo 5/10/20 M	PK 196 147 -T
Operations monitoring unit 1 for Duo 1.6/3/6/11 and Duo 5/10/20 M	PK 196 148 -T
Gas ballast valve - corrosive gas version	PK 194 144 -U
Gas ballast valve with magnet valve, 24 V DC	PK 194 343 -U

13 Technical data and dimensions

13.1 General

- Recommendations of PNEUROP committee PN5
- ISO 21360; 2007: "Vacuum technology - Standard methods for measuring vacuum-pump performance - General description"

Conversion table: pressure units

	mbar	bar	Pa	hPa	kPa	Torr mm Hg
mbar	1	$1 \cdot 10^{-3}$	100	1	0.1	0.75
bar	1000	1	$1 \cdot 10^5$	1000	100	750
Pa	0.01	$1 \cdot 10^{-5}$	1	0.01	$1 \cdot 10^{-3}$	$7.5 \cdot 10^{-3}$
hPa	1	$1 \cdot 10^{-3}$	100	1	0.1	0.75
kPa	10	0.01	1000	10	1	7.5
Torr mm Hg	1.33	$1.33 \cdot 10^{-3}$	133.32	1.33	0.133	1

1 Pa = 1 N/m²

Conversion table: gas throughput units

	mbar·l/s	Pa·m ³ /s	sccm	Torr·l/s	atm·cm ³ /s
mbar·l/s	1	0.1	59.2	0.75	0.987
Pa·m ³ /s	10	1	592	7.5	9.87
sccm	$1.69 \cdot 10^{-2}$	$1.69 \cdot 10^{-3}$	1	$1.27 \cdot 10^{-2}$	$1.67 \cdot 10^{-2}$
Torr·l/s	1.33	0.133	78.9	1	1.32
atm·cm ³ /s	1.01	0.101	59.8	0.76	1

13.2 Technical data

Parameter	Duo 3 DC	Duo 3 M DC
Flange (in)	DN 16 ISO-KF	DN 16 ISO-KF
Flange (out)	DN 16 ISO-KF	DN 16 ISO-KF
Pumping speed	2.5 m ³ /h	2.5 m ³ /h
Ultimate pressure with gas ballast	$\leq 3 \cdot 10^{-3}$ hPa	$\leq 3 \cdot 10^{-3}$ hPa
Ultimate pressure without gas ballast	$\leq 3 \cdot 10^{-3}$ hPa	$\leq 3 \cdot 10^{-3}$ hPa
Exhaust pressure, min.	Atmospheric pressure	250 hPa
Exhaust pressure, max.	1500 hPa	1500 hPa
Rotation speed	3000 min ⁻¹	3000 min ⁻¹
Leak rate safety valve	$\leq 1 \cdot 10^{-5}$ Pa m ³ /s	$\leq 1 \cdot 10^{-5}$ Pa m ³ /s
Emission sound pressure level without gas ballast	53 ±2 dB (A)	53 ±2 dB (A)
Ambient temperature	-20-+40 °C	-20-+40 °C
Protection category	IP20	IP20
Motor version	DC-Motor	DC-Motor
Supply: Voltage	24 V DC	24 V DC
Mains requirement: voltage (range)	±10 %	±10 %
Switch	No	No
Rated current absorption	9,8 A	9,8 A
Power consumption max.	0.34 kW	0.34 kW
Current consumption max.	16 A	16 A
Shipping and storage temperature	-25-+55 °C	-25-+55 °C
Operating fluid	Inland 45	Inland 45
Operating fluid filling	0.4 l	0.4 l
Gas ballast	Yes	Yes
Weight	7 kg	8 kg
Cooling method, standard	Air	Air

13.3 Dimensions

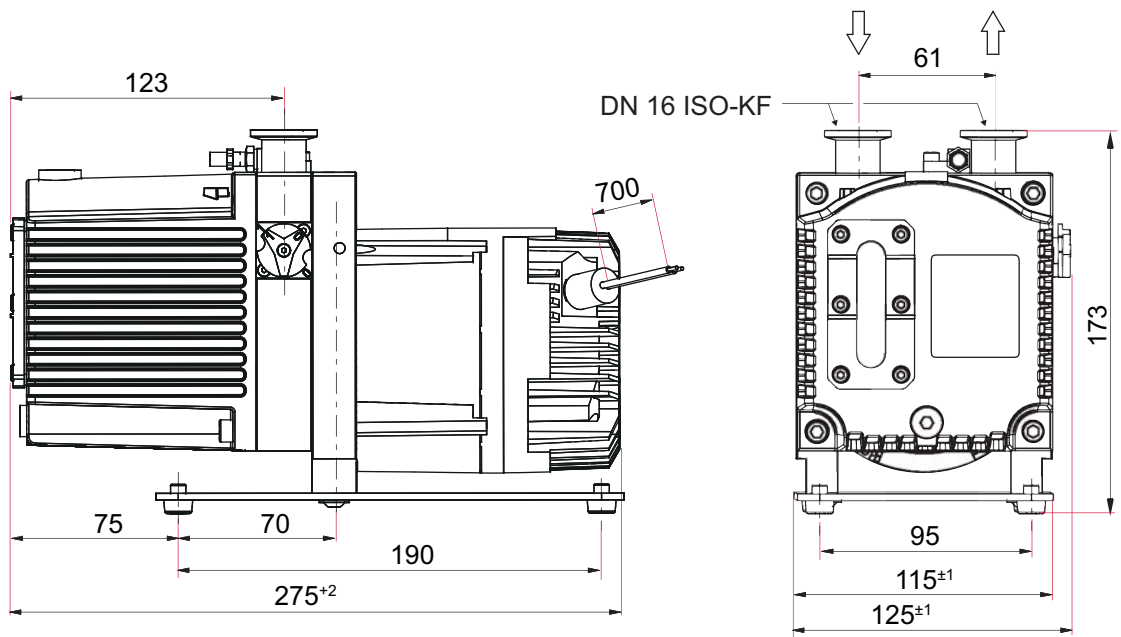

Fig. 14: DUO 3 DC

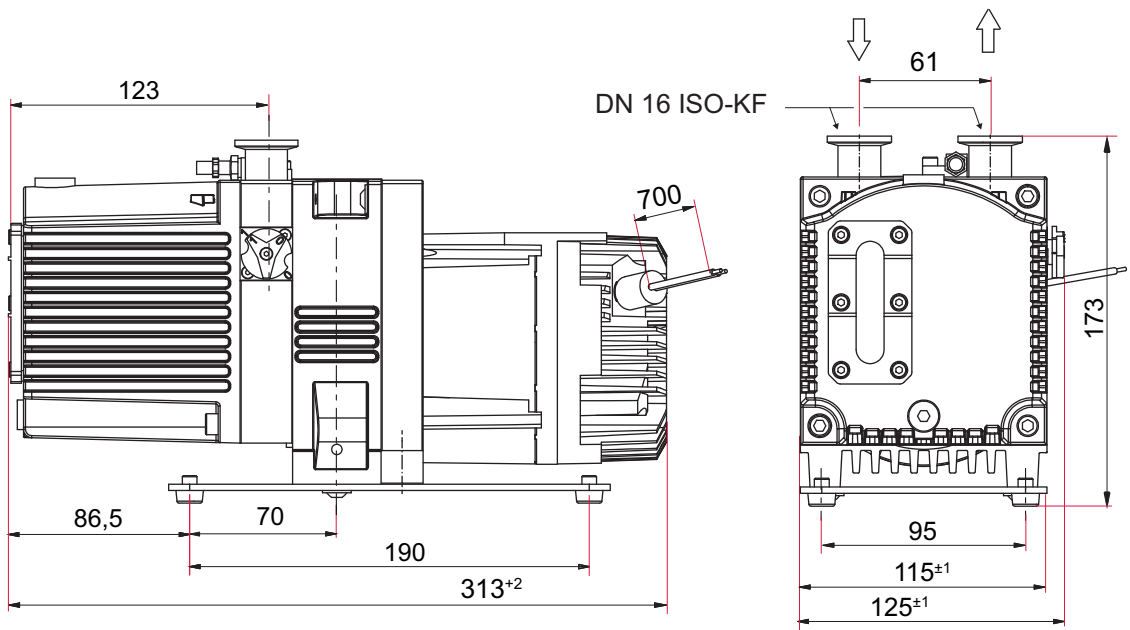

Fig. 15: DUO 3 M DC

Declaration of conformity

We hereby declare that the product cited below satisfies all relevant provisions according to the following **EC directives**:

- **Machinery 2006/42/EC (Annex II, no. 1 A)**
- **Electromagnetic Compatibility 2014/30/EU**
- **Restriction of the use of certain Hazardous Substances 2011/65/EU**

The agent responsible for compiling the technical documentation is Mr. Sebastian Oberbeck, Pfeiffer Vacuum GmbH, Berliner Straße 43, 35614 Aßlar.

DuoLine

DUO 3 DC / DUO 3 M DC

Harmonised standards and national standards and specifications which have been applied:

DIN EN ISO 12100 : 2010	DIN EN 61010-1 : 2010	DIN EN 61000-6-3 : 2007 + A1: 2011
DIN EN 1012-2 : 2011-12	DIN EN 61000-6-1 : 2007	DIN EN 61000-6-4 : 2007 + A1: 2011
DIN EN ISO 13857 : 2008	DIN EN 61000-6-2 : 2006	DIN EN ISO 2151 : 2: 2008
ISO 21360-1, 2 : 2012		

Signature:



(Dr. Ulrich von Hülsen)
Managing Director

VACUUM SOLUTIONS FROM A SINGLE SOURCE

Pfeiffer Vacuum stands for innovative and custom vacuum solutions worldwide, technological perfection, competent advice and reliable service.

COMPLETE RANGE OF PRODUCTS

From a single component to complex systems:

We are the only supplier of vacuum technology that provides a complete product portfolio.

COMPETENCE IN THEORY AND PRACTICE

Benefit from our know-how and our portfolio of training opportunities!

We support you with your plant layout and provide first-class on-site service worldwide.

Are you looking for a
perfect vacuum solution?
Please contact us:

Chemtech Scientific provides access to this content as a courtesy.

We do not own the content contained in this document.

All rights and credit go directly to its rightful owners.

www.chemtechsci.com

Call us at: 484-424-9415

