

# Original Operating Instructions V-VGD

V-VGD 10 | 15

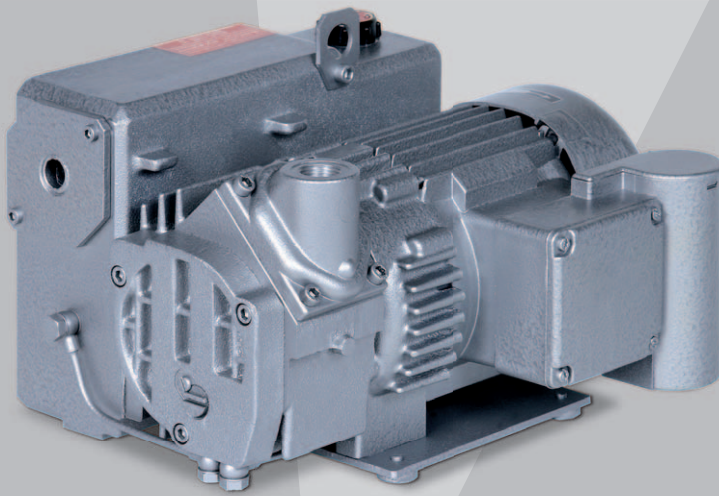

**V-Serie**  
**V-Series**  
Drehschieber  
Rotary Vane



## Table of contents

<b>1</b>	<b>Foreword</b> .....	<b>4</b>
1.1	Principles .....	4
1.2	Target group .....	4
1.3	Supplier documentation and accompanying documents .....	4
1.4	Abbreviations .....	4
1.5	Directives, standards, laws .....	4
1.6	Symbols and meaning .....	5
1.7	Technical terms and meaning .....	5
1.8	Copyright .....	5
<b>2</b>	<b>Safety</b> .....	<b>6</b>
2.1	Warning instruction markings .....	6
2.2	General .....	6
2.3	Designated use .....	7
2.4	Unacceptable operating modes .....	7
2.5	Personal qualifications and training .....	8
2.6	Safety-conscious work .....	8
2.7	Safety notes for the operator .....	8
2.8	Safety instructions for installing, commissioning and maintenance .....	9
2.9	Guarantee conditions .....	9
<b>3</b>	<b>Transport, storage and disposal</b> .....	<b>10</b>
3.1	Transportation .....	10
	3.1.1 Unpack and check the delivery condition .....	10
	3.1.2 Lifting and transporting .....	10
3.2	Storage .....	11
	3.2.1 Ambient conditions for storage .....	11
3.3	Disposal .....	11
<b>4</b>	<b>Set up and operation</b> .....	<b>12</b>
4.1	Setup .....	12
	4.1.1 Data plate .....	13
4.2	Description .....	13
4.3	Areas of application .....	13
<b>5</b>	<b>Installation</b> .....	<b>14</b>
5.1	Preparing for installation .....	14
5.2	Installation .....	14
5.3	Connecting pipes .....	15
5.4	Filling with lubricating oil .....	15
5.5	Connecting the motor .....	16
<b>6</b>	<b>Commissioning and decommissioning</b> .....	<b>17</b>
6.1	Commissioning .....	17
	6.1.1 Checking the rotation direction .....	18
	6.1.2 Setting the operating range .....	18
6.2	Decommissioning/ storing .....	19
6.3	Re-commissioning .....	19

<b>7</b>	<b>Maintenance and repair</b> .....	<b>20</b>
7.1	Ensuring operational safety .....	20
7.2	Maintenance work .....	20
	7.2.1 Air filtering .....	21
	7.2.2 Lubrication .....	22
	7.2.3 Entölung .....	23
7.3	Repair/ Service .....	24
7.4	Spare parts .....	25
<b>8</b>	<b>Malfunctions: Causes and elimination</b> .....	<b>26</b>
<b>9</b>	<b>Technical Data</b> .....	<b>29</b>

## Foreword

### 1 Foreword

#### 1.1 Principles

These operating instructions:

- are a part of the following oil-flooded rotary vane vacuum pumps, V-VGD 10 and V-VGD 15.
- describe how to use them safely and properly in all life phases.
- must be available where the equipment is used.

#### 1.2 Target group

The target group for these instructions is technically trained specialists.

#### 1.3 Supplier documentation and accompanying documents

Document	Contents	No.
Supplier documentation	Operating Instructions	BA 230-EN
	Declaration of Conformity	C 0042-EN
	Declaration of harmlessness	7.7025.003.17
Spare parts' list	Spare parts document	E 230
Data sheet	Technical data and graphs	D 230
Info sheet	Water vapour compatibility for oil-flooded vacuum pumps	I 200
Info sheet	Storage guidelines for machines	I 150
Manufacturer's declaration	EU Directive 2002/95/EG (RoHS)	—



#### 1.4 Abbreviations

Fig.	Figure
V-VGD	Vacuum pump
m <sup>3</sup> /h	Pumping capacity
mbar (abs.)	Final vacuum, operating vacuum

#### 1.5 Directives, standards, laws

See Conformity Declaration

## 1.6 Symbols and meaning

Symbol	Explanation
▷	Condition, pre-requisite
####	Instructions, action
a), b),...	Instructions in several steps
⇒	Results
 [-> 14]	Cross reference with page number
	Information, note
	Safety symbol Warns of potential risk of injury Obey all the safety instructions with this symbol in order to avoid injury and death.

## 1.7 Technical terms and meaning

Term	Explanation
Machines	Pump and motor combination ready to be connected
Motor	Pump drive motor
Vacuum pump	Machine to create a vacuum
Rotary vane	Machine's design or active principle
Pumping capacity	Vacuum pump volume flow related to the condition in the suction connection
Final pressure (abs.)	The maximum vacuum that a pump reaches when the suction opening is closed. Given as absolute pressure.
Permanent vacuum	The vacuum or the suction range at which the pump operates permanently. The permanent vacuum or intake pressure is $\geq$ than the final vacuum and $<$ than the atmospheric pressure.
Noise emission	The noise emitted at a specific loading given as a figure, sound pressure level dB(A) as per EN ISO 3744..





## 1.8 Copyright

Passing on or copying this document, using and providing information on its contents are prohibited unless expressly permitted.

## 2 Safety

The manufacturer is not responsible for damage if you do not follow all of this documentation.

### 2.1 Warning instruction markings

Warning	Danger level	Consequences if not obeyed
	immediately imminent danger	Death, severe bodily injury
	possible imminent danger	Death, severe bodily injury
	possible hazardous situation	Slight bodily injury
	possible hazardous situation	Material damage

### 2.2 General

These operating instructions contain basic instructions for installation, commissioning, maintenance and inspection work which must be obeyed to ensure the safe operation of the machine and prevent physical and material damage.

The safety instructions in all sections must be taken into consideration.

The operating instructions must be read by the responsible technical personnel/ operator before installing and commissioning and must be fully understood. The contents of the operating instructions must always be available on site for the technical personnel/ operator. Instructions fixed directly onto the machine must be obeyed and must always remain legible. This applies for example to:

- Symbols for connections
- Data and motor data plate
- Instruction and warning plates

The operator is responsible for observing local regulations.

### 2.3 Designated use

The machine must only be operated in such areas as are described in the operating instructions:

- only operate the machine in a technically perfect condition
- do not operate the machine when it is only partially assembled
- the machine must only be operated at an ambient temperature and a suction temperature of between 12 and 40°C  
Please contact us for temperatures outside this range.
- the machine may convey, compress or extract the following media:
  - Air  
The air extracted may contain water vapour but no water or other liquids. For water vapour compatibility see Info I 200
  - all non-explosive, non-inflammable, non-aggressive and non-poisonous dry gases and gas air mixtures

### 2.4 Unacceptable operating modes

- extracting, conveying and compressing explosive, inflammable, aggressive or poisonous media, e.g. dust as per ATEX zone 20-22, solvents as well as gaseous oxygen and other oxidants
- extracting, conveying and compressing explosive, inflammable, aggressive, oxidative or poisonous media, e.g. dust as per ATEX zone 20-22, solvents
- using the machine in non-commercial plants if the necessary precautions and protective measures have not been taken in the plant
- installing in environments that are at risk of explosions
- using the machine in areas with ionising radiation
- back pressures on the outlet side of more than +0,1bars
- modifications to the machine and accessories

## Safety

### 2.5 Personal qualifications and training

- Ensure that people entrusted with working on the machine have read and understood these operating instructions before starting work, particularly the safety instructions for installation, commissioning, maintenance and inspection work.
- Manage the responsibilities, competence and monitoring of staff
- all work must only be carried out by technical specialists:
  - Installation, commissioning, maintenance and inspection work
  - Working with electricity
- personnel being trained to work on the machine must be supervised by technical specialists only

### 2.6 Safety-conscious work

The following safety regulations apply in addition to the safety instructions and intended use listed in these instructions:

- Accident prevention regulations, safety and operating regulations
- the standards and laws in force

### 2.7 Safety notes for the operator

- hot parts of the machine must not be accessible during operation or must be fitted with a guard
- people must not be endangered by the free extraction or discharge of pumped media
- Risks arising from electrical energy must be eliminated.



## 2.8 Safety instructions for installing, commissioning and maintenance

- The operator will ensure that any installation, commissioning and maintenance work is carried out by authorised, qualified specialists who have gained sufficient information by an in-depth study of the operating instructions.
- Only work on the machine when it is idle and cannot be switched on again
- Ensure that you follow the procedure for decommissioning the machine described in the operating instructions.
- Fit or start up safety and protective devices again immediately after finishing work. Vor Wiederinbetriebnahme die aufgeführten Punkte für die Inbetriebnahme beachten
- Conversion work or modifications to the machine are only permissible with the manufacturer's consent.
- Only use original parts or parts approved by the manufacturer. The use of other parts may invalidate liability for any consequences arising.
- Keep unauthorised people away from the machine

## 2.9 Guarantee conditions

The manufacturer's guarantee or warranty will no longer apply in the following cases:

- Improper use
- Not complying with these instructions
- Operation by insufficiently qualified staff
- Using spare parts that have not been approved by **Gardner Denver Schopfheim GmbH**
- Unauthorised modifications to the machine or the accessories supplied by **Gardner Denver Schopfheim GmbH**

### 3 Transport, storage and disposal

#### 3.1 Transportation

##### 3.1.1 Unpack and check the delivery condition

- a) Unpack the machine on receipt and check for transport damage.
- b) Notify the manufacturer of transport damage immediately
- c) Dispose of the packaging in accordance with the local regulations in force.

##### 3.1.2 Lifting and transporting



#### WARNING

**Death or limbs crushed as a result of the items being transported falling or tipping over.**

- ▷ When transporting with the lifting device remember:
  - a) Select the lifting device suitable for the total weight to be transported.
  - b) Ensure that the machine cannot tip and fall.
  - c) Do not stop under a suspended load.
  - d) Put the goods to be conveyed on a horizontal base.

#### Lifting device/ Transporting with a crane



#### WARNING

**Bodily injury resulting from improper operation**

- a) Loads crosswise to the ring level are not permitted.
  - b) Avoid impact stress.
- 
- a) Tighten the fixing screw (Fig. 1/2) tightly to the transport shackle (Fig. 1/1) .
  - b) The machine must be suspended on the transport shackle using the lifting device for lifting and transporting.

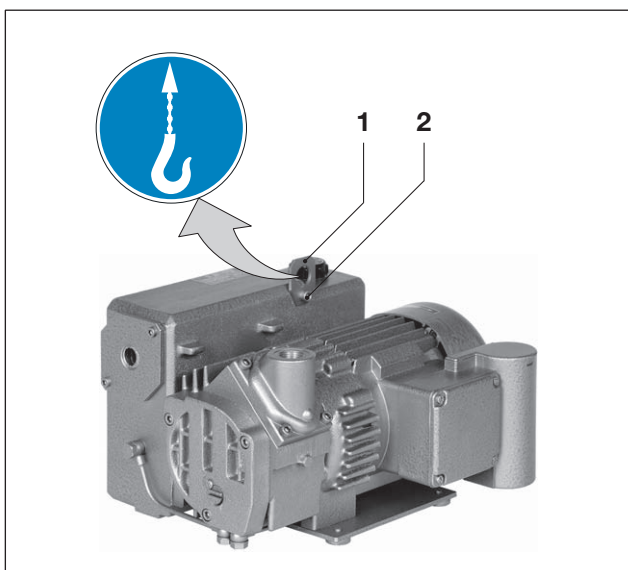

Fig. 1/1 Lifting and transporting

- 1 Transport shackle
- 2 Fixing screw

## 3.2 Storage

### NOTICE

#### Material damage caused by improper storage.

- ▷ Ensure that the storage area meets the following conditions:
  - a) dust free
  - b) vibration free

### 3.2.1 Ambient conditions for storage

Ambient conditions	Value
Relative humidity	0% to 80%
Lagertemperatur	-10°C to +60°C



For long-term storage (more than 3 months), it is useful to use a preservation oil rather than operating oil.

See Info “Machine storage guidelines” I 150

## 3.3 Disposal

### WARNING

#### Danger from inflammable, corrosive or poisonous substances.

Machines that come into contact with hazardous substances must be decontaminated before disposal.

- ▷ When disposing ensure the following:
  - a) Collect oils and grease separately and dispose of in accordance with the local regulations in force.
  - b) Do not mix solvents, limescale removers and paint residues
  - c) Remove components and dispose of them in accordance with the local regulations in force.
  - d) Dispose of the machine in accordance with the national and local regulations in force.
  - e) Parts subject to wear and tear (marked as such in the spare parts list) are special waste and must be disposed of in accordance with the national and local waste laws.

## 4 Set up and operation

### 4.1 Setup

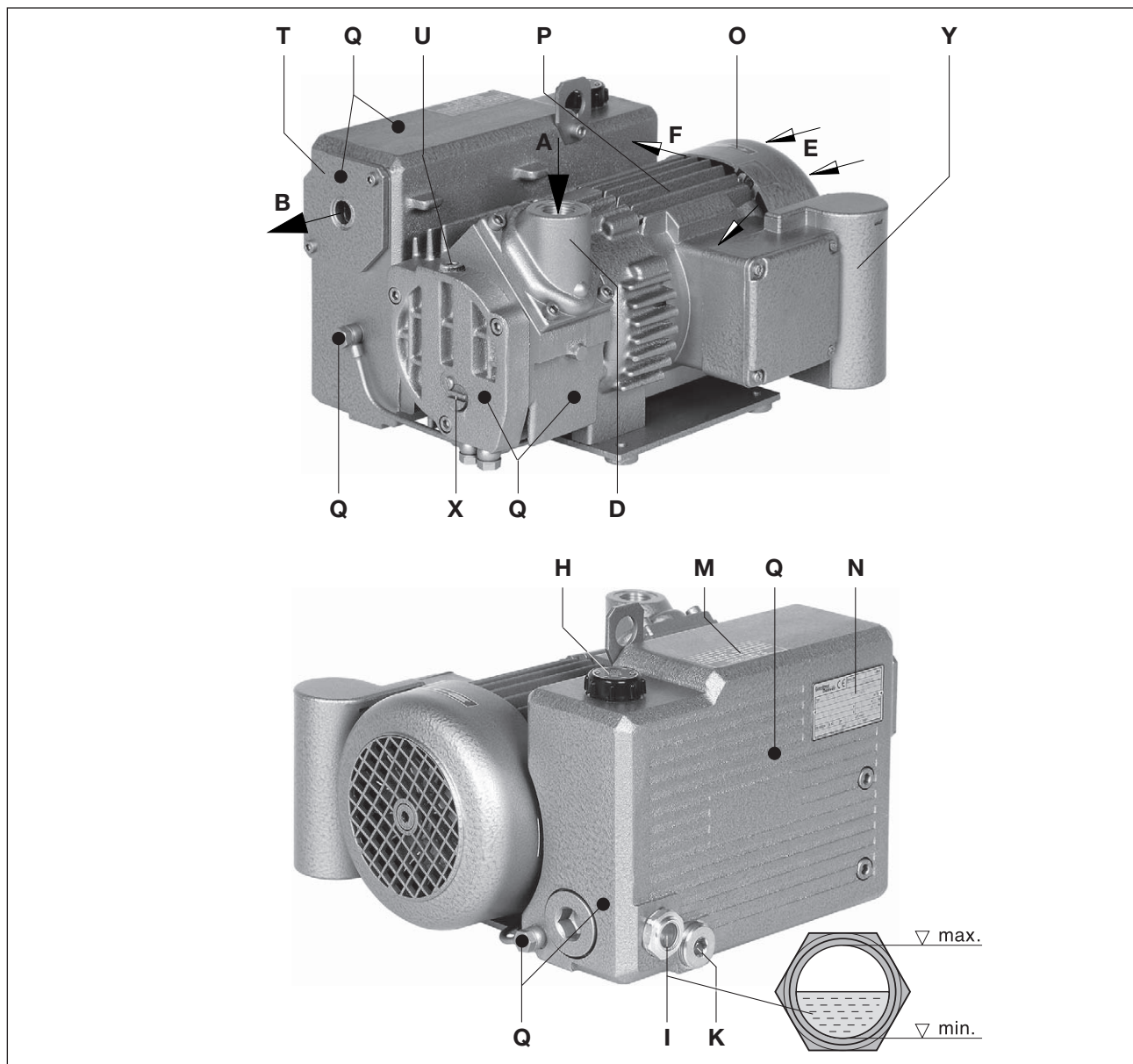

Fig. 2 Vacuum pump V-VGD 10 / V-VGD 15

- |          |                          |          |                               |
|----------|--------------------------|----------|-------------------------------|
| <b>A</b> | Vacuum connection        | <b>N</b> | Data plate                    |
| <b>B</b> | Exhaust air outlet       | <b>O</b> | Rotation direction plate      |
| <b>D</b> | Suction flange           | <b>P</b> | Drive motor                   |
| <b>E</b> | Cooling air inlet        | <b>Q</b> | hot surfaces > 70°C           |
| <b>F</b> | Cooling air outlet       | <b>T</b> | Purging cover                 |
| <b>H</b> | Oil filling point        | <b>U</b> | Gas ballast valve (accessory) |
| <b>I</b> | Oil sight glass          | <b>X</b> | Adjusting bolt                |
| <b>K</b> | Oil discharge point      | <b>Y</b> | Condenser (1~)                |
| <b>M</b> | Oil recommendation plate |          |                               |

### 4.1.1 Data plate

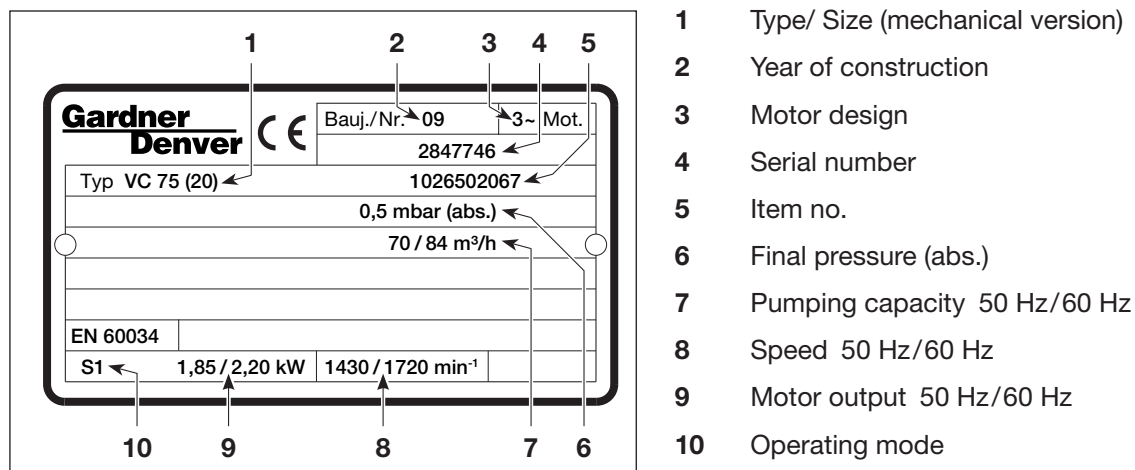

Fig. 3 Data plate (example)

### 4.2 Description

V-VGD has a fine micro filter on the suction side and on the outlet side an oil and oil mist separator to return the oil to the oil circulation system.

The motor fan cools the motor and pump housing. The motor and the pump have a common shaft.

An integral non-return valve prevents the evacuated system from being ventilated after the pump has stopped. If the machine has been idle for more than two minutes the connected pipe should be ventilated to atmospheric pressure.

A gas ballast valve ((Fig. 2/U) →Accessory) prevents water vapour condensation getting inside the pump when low amounts of steam are sucked in when the pump is at operating temperature.

### 4.3 Areas of application

These oil-flooded rotary vane vacuum pumps V-VGD 10 and V-VGD 15 are suitable for creating vacuum. The suction power with unrestricted suction is 10 and 15 m<sup>3</sup>/h at 50 Hz. The pumping capacity with unrestricted suction is 10 and 15 m<sup>3</sup>/h at 50 Hz. Data sheet D230.

The max. final vacuum (fine vacuum 2 mbars (abs.) or gross vacuum 10 mbars (abs.) can be specified by the operator (see adjustment bolt (Fig. 2/X)).

These types are suitable for the evacuation of closed systems or for a continuous vacuum within the following intake pressure ranges: Fine vacuum → 2 - 200 mbars (abs.) • Gross vacuum → 10 - 600 mbars (abs.).

If the unit is operated constantly outside these ranges there is the risk of oil leaking through the outlet opening. When evacuating closed systems the volume to be evacuated must be no more than 2% of the nominal pumping capacity of the vacuum pump.



If the unit is switched on more frequently (at regular intervals of about 10 times an hour) or at higher ambient temperatures and intake temperatures, the excess temperature limit of the motor winding and the bearings may be exceeded. Please contact the manufacturer should the unit be used under such conditions.



If it is installed in the open air the unit must be protected from environmental influences, (e.g. by a protective roof).

### 5 Installation

#### 5.1 Preparing for installation

Check the following points:

- Machine freely accessible from all sides
- Do not close ventilation grids and holes
- Sufficient room for installing and removing pipes and for maintenance work, particularly for installing and dismantling the machine
- No external vibration effects
- Do not suck any hot exhaust air from other machines into the cooling system.



The oil filling point (Fig. 2/H), oil sight glass (Fig. 2/I) and oil outlet (Fig. 2/K) must be easily accessible. The cooling air inlet (Fig. 2/E) and the cooling air outlets (Fig. 2/F) must be at least 15 cm away from adjacent walls. Cooling air coming out must not be sucked in again. For maintenance work there must be 30 cm in front of the angle flange (Fig. 2/D) and the purging cover (Fig. 2/T)

#### 5.2 Installation

##### **NOTICE**

**The machine may only be operated when it is set up horizontally.**

**Material damage resulting from the machine tipping over and falling.**

**When installed at more than 1000 m above sea level a reduction in power is noticeable. In this case we would ask you to contact us.**

Ensure that the foundation complies with the following conditions:

- Level and straight
- The bearing surface must be at least the same size as the machine
- The bearing surface must be able to bear the weight of the machine



It must be possible to install the machine on a firm foundation without anchoring. When installing on a substructure we recommend fixing with flexible buffers.

### 5.3 Connecting pipes

**NOTICE**

**Material damage resulting from the forces and torques of the pipes on the unit being too high.**  
Only screw pipes in by hand.

**The pumping capacity of the vacuum pump is reduced if the suction pipe is too narrow and/or too long.**

**The air vent (Fig. 2/B) must not be closed or restricted.**

**Counter pressures on the outlet side are only permissible up to + 0.1 bars.**

**Prevent liquids accumulating in the exhaust line.**

- a) The vacuum connection (Fig. 2/A) is on the angle flange (Fig. 2/D).
- b) The discharged air can be freely blown out through the exhaust air hole (Fig. 2/B) or conducted away using a hose or pipe.

### 5.4 Filling with lubricating oil

- a) Fill the lubricating oil (for suitable types see the „Maintenance“ section) via the oil filling point (Fig. 2/H) up to the upper edge of the sight glass (Fig. 2/I).
- b) Close the oil filling point.

### 5.5 Connecting the motor



#### **DANGER**

**Danger of death if the electrical installation has not been done professionally.**

The electrical installation must only be done by a qualified electrician observing EN 60204. The operating company has to provide the main switch.

- a) The electrical motor data can be found on the data plate (Fig. 2/N). The motors comply with DIN EN 60034 and are in protection class IP55 and insulation class F. The appropriate connection diagram is located in the motor's terminal box (not for the plug connection version). The motor data must be compared with the data of the existing mains network (current type, voltage, network frequency, permitted current value).
- b) Connect the motor via the motor protection switch (for safety reasons, a motor protection switch is required and the connecting cable must be installed via a cable fitting to provide strain relief). SFibWe recommend using motor protection switches with delayed switch off, depending on possible excess current. Temporary excess current can occur when the machine is started cold.

#### **NOTICE**

##### **Power supply**

The conditions at the installation location must match the information on the motor data plate. Without derating the following is permissible:

- $\pm 5\%$  Voltage deviation
- $\pm 2\%$  Frequency deviation



## 6 Commissioning and decommissioning

### 6.1 Commissioning

#### WARNING

##### **Improper use**

May lead to severe or fatal injuries. Therefore be sure to obey the safety instructions.



#### CAUTION

##### **Hot surfaces**

When the machine is at operating temperature the surface temperatures on the components (Fig. 2/Q) may go above 70°C. You must avoid touching the hot surfaces (marked with warning plates).



#### CAUTION

##### **Noise emission**

The highest noise pressure levels measured as per EN ISO 3744 are given in Section 9. When spending a long time in the vicinity of the running machine use ear protectors to avoid permanent damage to your hearing.

#### CAUTION

##### **Oil aerosols in the extracted air**

In spite of the air oil removing system separating the oil mist to a large extent, the extracted air contains a small residue of oil aerosols. Breathing in these aerosols all the time could damage your health. Therefore you must ensure that the installation room is well ventilated.

## Commissioning and decommissioning

### 6.1.1 Checking the rotation direction

- ▷ The drive shaft direction of rotation is shown by the rotation direction arrow (Fig. 2/O) on the motor flange.
- a) Start the motor briefly (max. two seconds) to check the direction of rotation. When looking at the motor fan, it must rotate anti-clockwise.

#### NOTICE

##### Incorrect direction of rotation

Operating in the wrong direction of rotation leads to damage to the machine.

Use a phase sequence indicator to check the direction of rotation (**clockwise rotating field**).

- b) After correcting the direction of rotation if necessary, start the motor again and stop it again after 2 minutes in order to top missing oil up to the upper edge of the sight glass (Fig. 2/I). The filling point must not be open when the pump is running.

### 6.1.2 Setting the operating range

- ▷ The operating range can be set by turning the adjusting bolt (Fig. 2/X, 4/X).

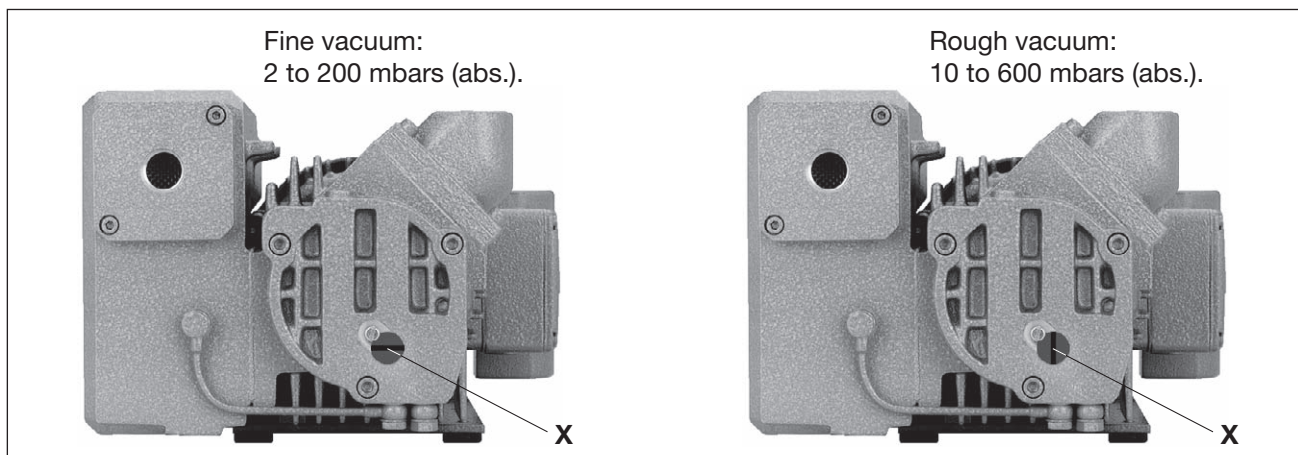

Fig. 4 Setting the operating range

X Adjusting bolt

### 6.2 Decommissioning/ storing

#### Stop the machine

- a) Switch the machine off.
  - b) Falls vorhanden, Absperrorgan in Saug- und Druckleitung schließen.
  - c) Disconnect the machine from the electricity source.
  - d) Maschine druckentlasten:  
Rohrleitungen langsam öffnen.  
⇒ The pressure reduces slowly.
  - e) Remove the pipes and hoses.
  - f) Seal the connections for suction and discharge nozzles with adhesive foil.
- 📖 see also Section 3.2.1, Page 11

### 6.3 Re-commissioning

- a) Check the condition of the machine (cleanliness, cabling etc.).
  - b) Drain the preserving agents.
- 📖 For installation see Section 5 Page 14
- 📖 For commissioning see Section 6.1 Page 17

## 7 Maintenance and repair



### **DANGER**

**Danger of death from touching live parts.**

Before maintenance work disconnect the machine by pressing the main switch or unplugging it and ensure that it cannot be turned on again.



### **WARNING**

**Hot surfaces and equipment**

During maintenance work there is the danger of getting burnt on hot components (Fig. 2/Q) and by the machine lubricating oil. Wait for the machine to cool down.

### 7.1 Ensuring operational safety

Regular maintenance work must be carried out in order to ensure operational safety.

Maintenance intervals also depend on the operational demands on the machine.

With any work observe the safety instructions described in Section 2.8 “Safety notes for installation, commissioning and maintenance”.

The whole unit should always be kept in a clean condition.

### 7.2 Maintenance work

Interval	Maintenance to be carried out	Section
monthly	Check the pipes and screws for leaks and to ensure they are seated properly and if necessary seal again or tighten up.	—
monthly	Check the terminal box and cable inlet holes for leaks and if necessary re-seal.	—
monthly	Clean the ventilation slots on the machine and the motor cooling ribs.	—
depending on how dirty the discharged medium is.	Clean intake air filter	7.2.1
daily	Check the oil level	7.2.2
500 - 2000 h	Change the oil	
2000 h	Change the oil separator elements	7.2.3

## 7.2.1 Air filtering

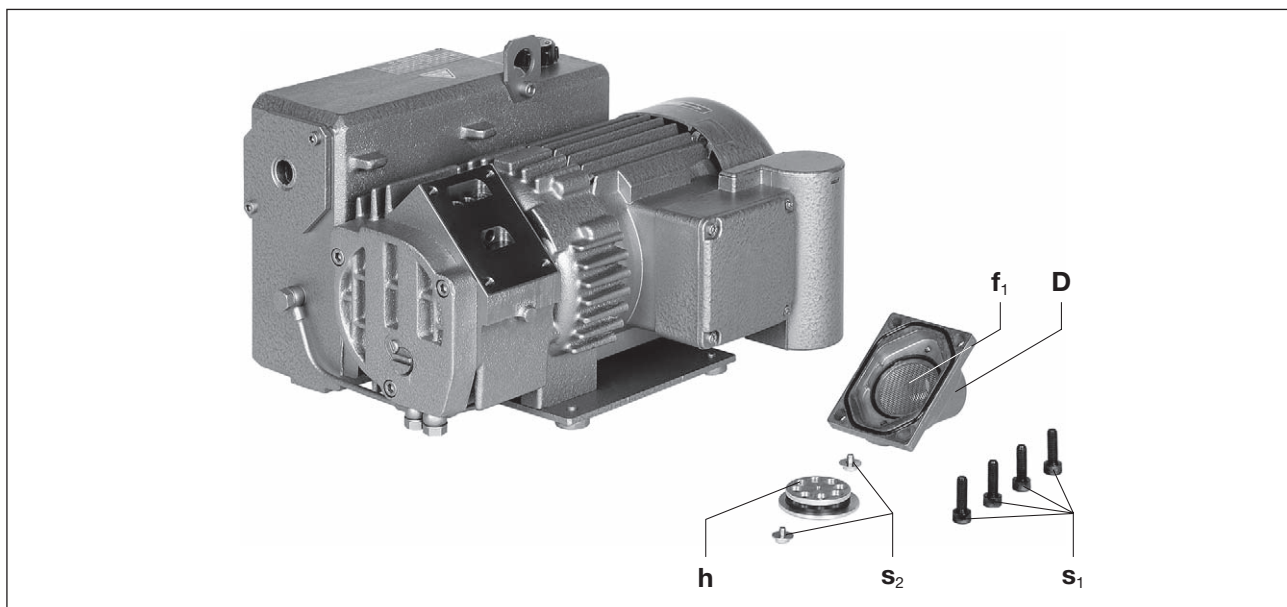

Fig. 5 Air filtering

- D** Suction flange
- h** Non-return valve
- f<sub>1</sub>** Micro filter
- s<sub>1</sub>** Screws
- s<sub>2</sub>** Screws

**NOTICE****Insufficient maintenance on the air filter**

The power of the machine lessens and damage may occur to the machine.

The micro filter (Fig. 5/f<sub>1</sub>) must be cleaned by rinsing out or purging or replaced more or less often depending on how dirty the discharged medium is. Also check the non-return valve (Fig. 5/h) for contamination.

Remove the filter housing (Fig. 5/D) after undoing the screws (Fig. 5/s<sub>1</sub>). Remove the non-return valve (Fig. 5/h) from the suction flange after undoing the screws (Fig. 5/s<sub>2</sub>).

Re-assemble in reverse order.

7.2.2 Lubrication

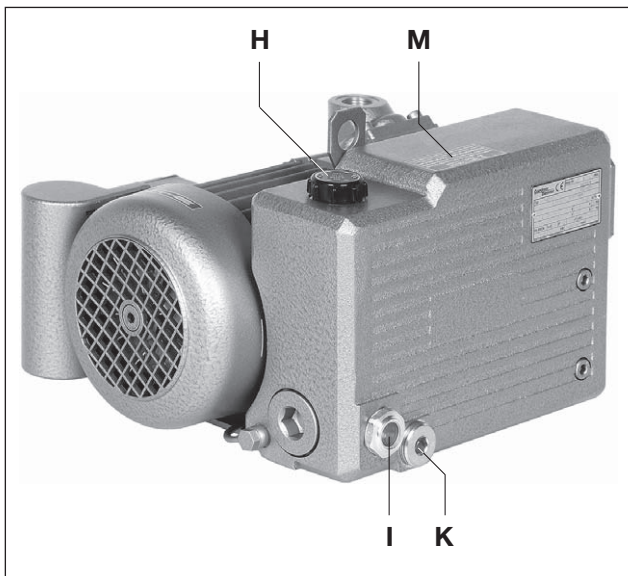

Fig. 6 Lubrication

- H** Oil filling point
- I** Oil sight glass
- K** Oil discharge point
- M** Oil recommendation plate

**NOTICE**

Always change the oil when the machine is at operating temperature and in an atmospherically ventilated area. If it is not completely emptied the amount that can be refilled is reduced.

The waste oil must be disposed of in compliance with the local environmental protection regulations. If you are going to use another oil type, empty the oil removing device housing and oil cooler completely.

The oil level must be checked at least once a day, if necessary top the oil up to the upper edge of the sight glass (Fig. 6/I) First oil change after 500 hours of operation. Subsequent oil changes after 500-2000 hours of operation. Reduce the change intervals accordingly depending on how contaminated the discharged medium is. Only lubricating oils complying with DIN51506 group VC/VCL or a synthetic oil approved by Elmo Riettschle must be used. The viscosity of the oil must comply with ISO-VG46 as per DIN51519. *Elmo Riettschle oil types:* MULTI-LUBE 46 (mineral oil) and SUPER-LUBE46 (synthetic oil) see also oil recommendation plate (Fig. 6/M)). If the oil is subject to high temperatures (ambient or intake temperatures over 30°C, insufficient cooling, 60 Hz operation etc.) the oil change interval may be extended by using the recommended synthetic oil.

## 7.2.3 Entölung

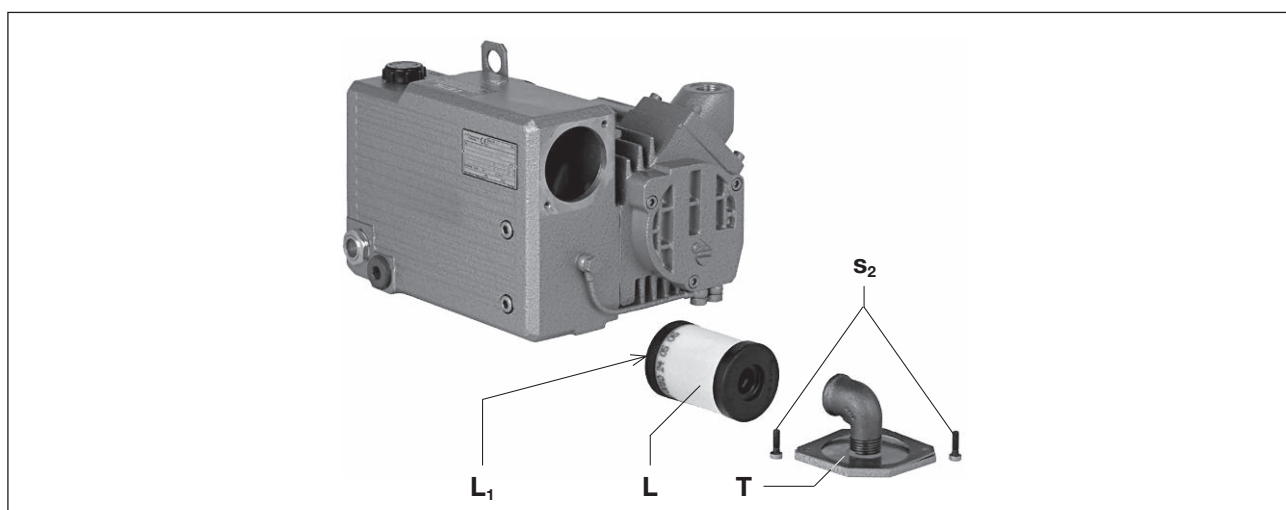

Fig. 7 Oil removal

- L** Oil separator element
- L<sub>1</sub>** O ring
- T** Purging cover
- S<sub>2</sub>** Screws

**⚠ WARNING**

Heavily contaminated air oil removing devices lead to increased pump temperatures and in extreme cases may cause the lubricating oil to ignite spontaneously.

The oil separator element may be contaminated with particles of dirt when it has been running for a long time (power consumption and pump temperature increase). Replace the device (Fig. 7/L) every 2000 operating hours because it is not possible to clean it.

Reduce the change intervals accordingly depending on how contaminated the discharged medium is.

Changing: Remove the purging cover (Fig. 7/T) and the gasket after undoing the screws (Fig. 7/S<sub>2</sub>). Unscrew the oil separator element (Fig. 7/L) with a hexagonal wrench (size 10) and replace.

**NOTICE**

Ensure that the O ring is correctly seated on the new oil separator element.

Re-assemble in reverse order. Before fitting lightly oil the O ring (Fig. 7/L<sub>1</sub>) on the new oil removing device and tighten it to 15 Nm.

7.3 Repair/ Service

- a) For on site repair work the motor must be disconnected from the mains by a qualified electrician so that it cannot be started up again accidentally. For repairs use the manufacturer, its branch offices or authorised dealers. Please contact the manufacturer for the address of the service centre responsible for you (see Manufacturer’s address).

The image shows a clear photocopy of a 'Gardner Denver' clearance certificate form. The form is titled 'Unbedenklichkeitsklärung für Vakuumpumpen und Komponenten' and includes fields for machine details, a declaration of safety, and contact information for the technician. The form is numbered 7.7025.003.17 and is page 1 of 1.

Fig. 8 Clearance certificate 7.7025.003.17

**NOTICE**

For each machine that is sent to an Elmo Riet-schle Service centre for inspection, maintenance or repair, a fully completed, signed declaration of harmlessness must be enclosed.

The declaration of harmlessness is part of the supplier’s documentation.

- b) After a repair or re-commissioning, the actions listed under „Installation“ and „Commissioning“ must be carried out as for initial commissioning..



7.4 Spare parts

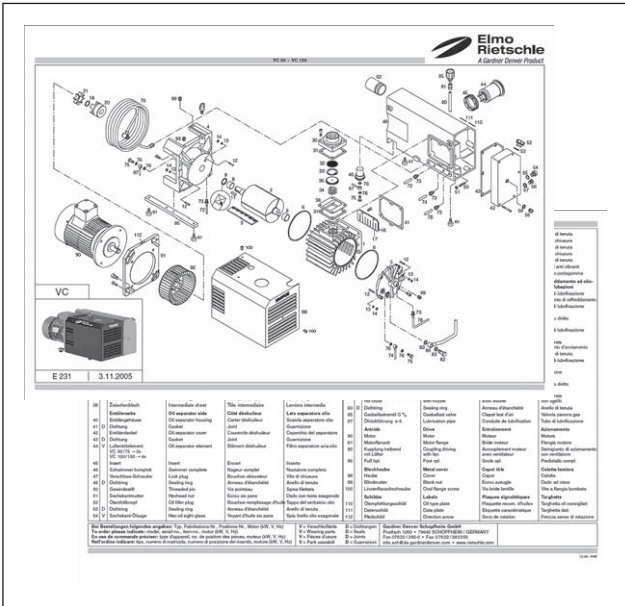

Fig. 9 Ersatzteilliste (Beispiel)

Order spare parts in accordance with the:

- Spare parts list :  
E 230 → V-VGD 10 / V-VGD 15
  - Downloads
  - Product Documents
  - V-Series → Spare Parts
- Parts subject to wear and gaskets are indicated separately on the list.
- Select the type, size and design.

**NOTICE**

Only use original spare parts or parts approved by the manufacturer. The use of other parts may lead to malfunctions and invalidate liability or the guarantee for any consequences arising.

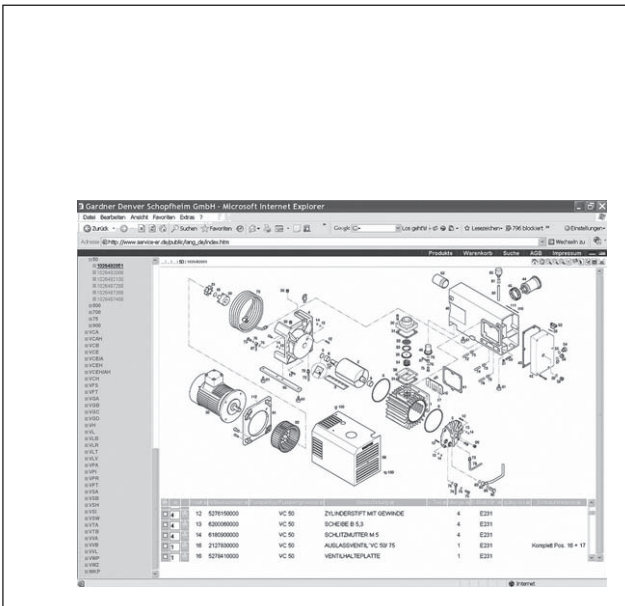

## 8 Malfunctions: Causes and elimination

Fault	Cause	Troubleshooting	Important
Machine is switched off by the motor protection switch	Mains voltage/ Frequency does not correspond with the motor data	Check by qualified electrician	Section 5.5
	Connection to motor terminal board is not correct		
	Motor protection switch is not set correctly		
	Motor protection switch is triggered too quickly	Use a motor protection switch with an overload-dependent delayed switch off that takes into consideration the short term excess current at start up (version with short circuit and overload trigger as per VDE 0660 Part 2 or IEC 947-4)	
	Vacuum pump or its oil is too cold	Note the ambient temperature and the intake temperature	Section 2.3
	The lubricating oil is too viscous	The oil viscosity must comply with ISO VG 46 as per DIN 51519	Section 7.2.2
	The oil separator element is dirty.	Change the oil separator element	Section 7.2.3
The back pressure is too high when the exhaust air is being discharged.	Check the hose or the pipe	Section 5.3	
Pumping capacity is insufficient	The suction pipe is too long or too narrow	Check the hose or the pipe	Section 5.3
	Leak on the suction side of the vacuum pump or in the system	Check the pipework and screw connections for leaks and to ensure that they are firmly seated.	Section 7.2
	The intake filter is dirty	Clean or replace the intake filter	Section 7.2.1

<b>Fault</b>	<b>Cause</b>	<b>Troubleshooting</b>	<b>Important</b>
Final pressure (max. vacuum) is not reached	Leak on the suction side of the vacuum pump or in the system	Check the pipework and screw connections for leaks and to ensure that they are firmly seated.	Section 7.2
	Incorrect oil viscosity	The oil viscosity must comply with ISO VG 46 as per DIN 51519	Section 7.2.2
	The adjustment bolt (X) is not set correctly.	Set the operating range correctly.	Section 6.1.2
Machine gets too hot	Ambient or intake temperature is too high	Ensure it is being used properly	Section 2.3
	Cooling air supply is obstructed	Check environmental conditions	Section 5.1
		Clean ventilation slots	Section 7.2
	The lubricating oil is too viscous	The oil viscosity must comply with ISO VG 46 as per DIN 51519	Section 7.2.2
	The oil separator element is dirty.	Change the oil separator element	Section 7.2.3
The back pressure is too high when the exhaust air is being discharged.	Check the hose or the pipe	Section 5.3	
Exhaust air contains visible oil mist	The oil separator element is not inserted correctly or the O ring is missing	Check that it is correctly seated	Section 7.2.3
	Unsuitable oil is being used	Use suitable types	Section 7.2.2
	The oil separator element is dirty.	Change the oil separator element	Section 7.2.3
	The back pressure is too high when the exhaust air is being discharged.	Check the hose or the pipe	Section 5.3
	Ambient or intake temperature is too high	Ensure it is being used properly	Section 2.3
	Cooling air supply is obstructed	Check environmental conditions	Section 5.1
Clean ventilation slots		Section 7.2	

## Malfunctions: Causes and elimination

Fault	Cause	Troubleshooting	Important
The machine makes a abnormal noise (The blades making a hammering noise when starting from cold is normal if it disappears within two minutes as the operating temperature increases)	The pump housing is worn (chatter marks)	Repair by manufacturer or authorised workshop	Elmo Rietschle Service
	Blades are damaged	Repair by manufacturer or authorised workshop	Elmo Rietschle Service
	Vacuum pump or its oil is too cold	Note the ambient temperature and the intake temperature	Section 2.3
	The lubricating oil is too viscous	The oil viscosity must comply with ISO VG 46 as per DIN 51519	Section 7.2.2
Water in lubricating oil	Pump sucks in water	Install water interceptor upstream of the pump	—
	The pump sucks in more water vapour than is suitable for its water vapour compatibility	Contact the manufacturer for increased gas ballast	—
	Pump only works for a short time and therefore does not reach its normal operating temperature	Let the pump continue to run with a closed suction side after extracting the water vapour until the water has evaporated from the oil	—
<b>Please contact Elmo Rietschle Service for other malfunctions or those that cannot be eliminated.</b>			

## 9 Technical Data

V-VGD		10	15	
Sound pressure level (max.) EN ISO 3744 Tolerance $\pm 3$ dB(A)	dB(A)	50 Hz	63	66
		60 Hz	66	67
Weight*	kg	19		
Length*	mm	295		
Width	mm	270		
Height	mm	185		
Vacuum connection		G 1/2		
Exhaust air outlet		G 1/2		
Correct amount of oil	l	0,4		

\* The length and the weight may differ from the information listed here depending on the motor design.

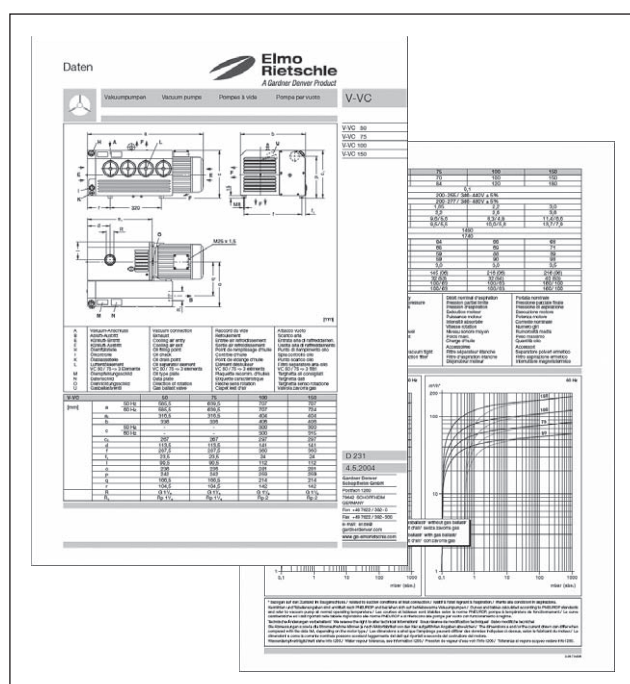
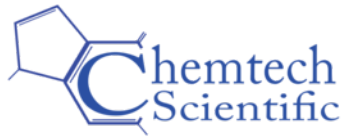

Fig. 11 Data sheet (example)

You will find more technical data on the data sheet **D 230**

- Download the PDF file **D 230** → V-VGD 10 / V-VGD 15
  - Downloads
  - Product Documents
  - V-Series → Data Sheets

**NOTICE**  
Subject to technical changes.



## EC - declaration of conformity 2006/42/EC

**Hereby the manufacturer confirms:** Gardner Denver Schopfheim GmbH  
Postfach 1260  
D-79642 Schopfheim

**that the machine:** Oil lubricated vacuum pump

**of the:** Series: V-VGD  
Type: V-VGD 10, V-VGD 15

**is conform to the regulations of the guideline indicated above.**

The following harmonized and national standards and specifications are applied:

EN 1012-1:2010 Compressors and vacuum pumps — Safety requirements — Part 1:  
Compressors

EN 1012-2:1996+A1:2009 Compressors and vacuum pumps — Safety requirements — Part 2:  
Vacuum pumps

These declarations of conformity are invalid when the machine has been modified without prior approval by us and the approval has been documented in writing.

Name and address of the EC person in charge for documentation Gardner Denver Schopfheim GmbH  
Postfach 1260  
D-79642 Schopfheim

Gardner Denver Schopfheim GmbH  
Schopfheim, 1.8.2011

  
\_\_\_\_\_  
Dr. Friedrich Justen, Director Engineering

### Gardner Denver Schopfheim GmbH

Roggenbachstr. 58, 79650 Schopfheim Phone: +49/(0)7622/392-0 Fax: +49/(0)7622/392-300

Repairs and/or maintenance of vacuum pumps and components will only be carried out if a declaration has been filled in correctly and completely.

If not, the repair work cannot be started and delays will result.

This declaration must only be filled in and signed by authorised qualified staff.

1. Type of vacuum pumps/ components	2. Reason for the submission
Type description: _____	_____
Machine number _____	_____
Order number: _____	_____
Delivery date: _____	_____

3. Condition of vacuum pumps/ components	4. Contamination of the vacuum pumps/ components when in use
Was this being operated? YES <input type="checkbox"/> NO <input type="checkbox"/>	Toxic YES <input type="checkbox"/> NO <input type="checkbox"/>
Which lubrication was used? _____	Corrosive YES <input type="checkbox"/> NO <input type="checkbox"/>
Was the pump/ component emptied? (Product/Consumables) YES <input type="checkbox"/> NO <input type="checkbox"/>	Microbiological*) YES <input type="checkbox"/> NO <input type="checkbox"/>
Has the pump/ component been cleaned and decontaminated? YES <input type="checkbox"/>	Explosive*) YES <input type="checkbox"/> NO <input type="checkbox"/>
	Radioactive*) YES <input type="checkbox"/> NO <input type="checkbox"/>
	other YES <input type="checkbox"/> NO <input type="checkbox"/>

Cleaning agent: \_\_\_\_\_

Cleaning method: \_\_\_\_\_

\*) Microbiological, explosive or radioactively contaminated vacuum pumps/ components will only be accepted with proof that they have been cleaned properly.

Type of toxic substance or process-related, dangerous reaction products with which the vacuum pumps/ components came into contact:

Trade name, manufacturer's product name	Chemical name	Hazard class	Action to be taken if toxic substances are released	First aid in the event of accidents
1				
2				
3				
4				

Personal protection measures: \_\_\_\_\_

Hazardous decomposition products when subjected to thermal load YES  NO

Which? \_\_\_\_\_

### 5. Legally binding declaration

We swear that the information in this declaration is accurate and complete and that I, the undersigned, am in a position to judge this. We are aware that we are liable to the contractor for damage caused by incomplete and inaccurate information. We undertake to release the contractor from any damage claims from third parties arising from incomplete or incorrect information. We are aware that, regardless of this declaration, we are directly liable to third parties including in particular the contractor's staff entrusted with handling or repairing the product.

Company: \_\_\_\_\_

Street: \_\_\_\_\_ Post code/ Town: \_\_\_\_\_

Phone: \_\_\_\_\_ Fax: \_\_\_\_\_

Name (in capitals) \_\_\_\_\_ Position: \_\_\_\_\_

Date: \_\_\_\_\_ Company stamp: \_\_\_\_\_

Legally binding signature: \_\_\_\_\_