

Vacuum pumps

VTB 180

VTB 250

VTB 340

VTB 500

VTB (01)

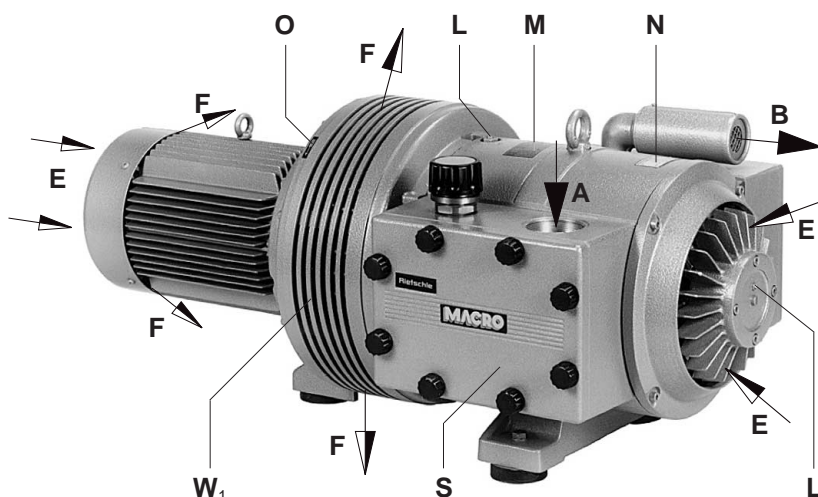

Pump ranges

These operating instructions concern the following dry running rotary vane vacuum pumps: Models VTB 180 to VTB 500.

Version (01) → cooling air exits through slots on the fan housing see pictures 1

Version (31) → cooling air exits out of the spiral housing see pictures 2

The vacuum capacities at atmosphere are 170, 250, 350 and 510 m³/hr operating on 50 cycles. The pumping curves showing capacity against pressure can be found in data sheets:

D 267/1 → VTB 180 - VTB 500 (01) • D 267/2 → VTB 180 - VTB 500 (31)

Description

All models are complete with an inlet threaded connection and a silencer on the exhaust. All the air handled is filtered by a built-in micro-fine filter. A high efficiency cooling fan that pulls air in is situated between the pump housing and the motor. On version (01) the fan is located in the fan housing (see pictures 1). The heated cooling air (F) is radially exhausted out of the fan housing. On version (31) the fan is located in a spiral housing (see pictures 2). In this case the heated cooling air (F) can be directed either upwards or to the side depending on the position of the spiral housing (W₂). It is also possible to connect ducting to the spiral housing so that the cooling air (F) can be transported away from the unit.

All the pumps are driven by a direct flanged three phase, standard TEFV motor via a pin and bush coupling.

Optional extras: As required, vacuum regulating valve (ZRV), non return valve (ZRK), inlet dust filter (ZFP), vacuum tight suction filter (ZVF), motor starter (ZMS), softstarter (ZAD), unloading valve (ZAE), various vacuum gauges (ZVM) and acoustic enclosure (ZBX).

BE 267

1.8.2000

VTB (31)

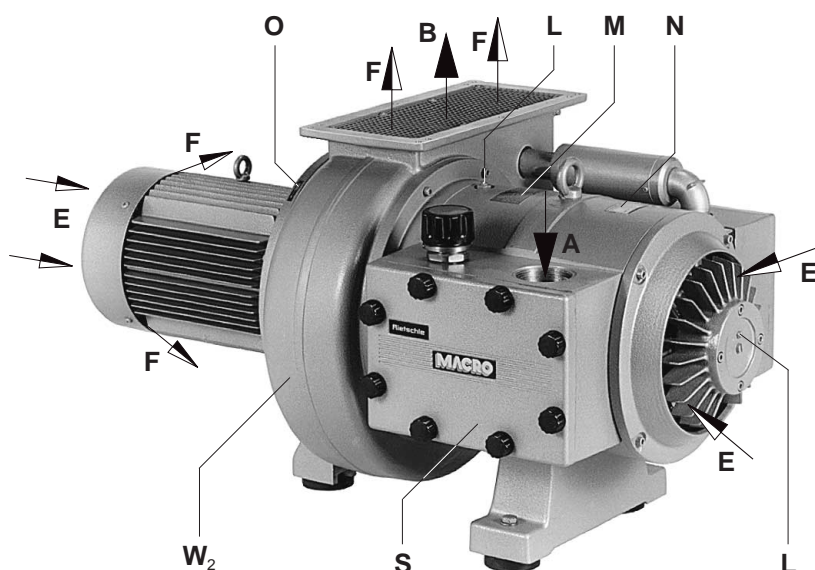

Suitability

! The units VTB are suitable for use in the industrial field i.e. the protection equipment corresponds to EN DIN 294 table 4, for people aged 14 and above.

The VTB can be used for the evacuation of a closed system or for a permanent vacuum from 200 to 1000 mbar (abs.).

! The ambient and suction temperatures must be between 5 and 40°C. For temperatures outside this range please contact your supplier.

These dry running vacuum pumps are suitable for use with air of a relative humidity of 30 to 90%.

! Dangerous mixtures (i.e. inflammable or explosive gases or vapours), extremely humid air, water vapour, aggressive gases or traces of oil and grease must not be handled. The standard versions may not be used in hazardous areas. Special versions with Ex-proof motors can be supplied.

! For all applications where an unplanned shut down of the vacuum pump could possibly cause harm to persons or installations, then the corresponding safety backup system must be installed.

VTB (01)

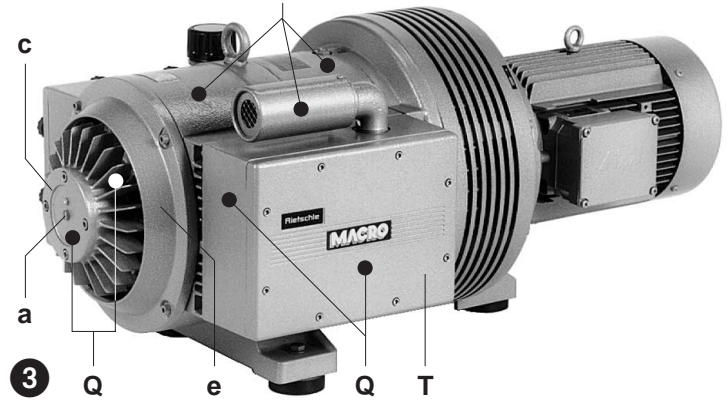

Handling and Setting up

! Pumps that have reached operating temperature may have a surface temperature at position (Q) of more than 70°C. **WARNING! Do Not Touch.** (see pictures 3 and 4)

The filter housing (S), exhaust box (T), housing cover (b) and greasing points (L) must all be easily accessible. For maintenance purposes we recommend a space of 0.4 m in front of the filter housing and housing cover. The cooling air entries (E) and the cooling air exits (F) must have a minimum distance of 20 cm from any obstruction. The discharged cooling air must not be re-circulated. If the cooling air exits from the spiral housing (W₂) via ducting, then care should be taken so that the passage of air is not obscured. (see pictures 1 to 4)

The VTB pumps can only be operated reliably if they are installed horizontally.

! For installations that are higher than 1000 m above sea level there will be a loss in capacity. For further advice please contact your supplier.

When installed on a solid base, these pumps do not require fixing down. If the pumps are installed on a base plate we would recommend fitting anti-vibration mounts. This range of vacuum pumps is almost vibration free in operation.

Installation (pictures 1 to 4)

! For operating and installation follow any relevant national standards that are in operation.

1. Vacuum connection at (A).

The air handled can be exhausted into the atmosphere through the exhaust port (B) or on models VTB (31) by directing the air through the spiral housing (W₂).

! Long and/or small bore pipework should be avoided as this tends to reduce the capacity of the pump.

2. The electrical data can be found on the data plate (N) or the motor data plate. The motors correspond to DIN/VDE 0530 and have IP 54 protection and insulation class B or F. The connection diagram can be found in the terminal box on the motor (unless a special plug connection is fitted). Check the electrical data of the motor for compatibility with your available supply (voltage, frequency, permissible current etc.).

3. Connect the motor via a motor starter. It is advisable to use thermal overload motor starters to protect the motor and wiring. All cabling used on starters should be secured with good quality cable clamps.

We recommend that motor starters should be used that are fitted with a time delayed trip resulting from running beyond the amperage setting. When the unit is started cold, over-amperage may occur for a short time.

! The electrical installation may only be made by a qualified electrician under the observance of EN 60204. The main switch must be provided by the operator.

Initial Operation (pictures 1 and 2)

1. Initially switch the pump on and off for a few seconds to check the direction of rotation against the direction arrow (O).

Note: On this initial start the suction pipework should not be connected. If the pump runs backwards with the pipework connected a pressure could build up within the housing which could result in damaged rotor blades.

2. Connect the suction pipe at (A).

! For pipe work longer than 3 m we recommend using non-return-valves (ZRK), to avoid reverse rotation when the units are switched off.

3. Vacuum regulating valve (optional extra):

The vacuum can be adjusted by turning the regulating valve (C) according to the symbols on the top of the regulating valve.

Potential risks for operating personnel

Noise Emission: The worst noise levels considering direction and intensity (sound power), measured according to DIN 45635 part 3 (as per 3. GSGV), are shown in the table at the back. When working permanently in the vicinity of an operating pump we recommend wearing ear protection to avoid any damage to hearing.

VTB (31)

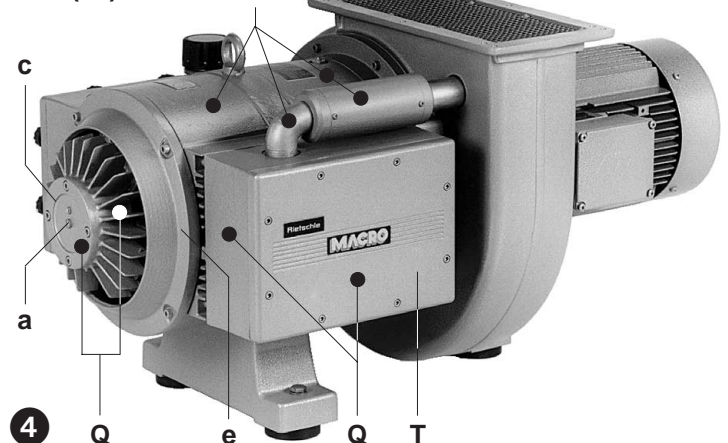

Maintenance and Servicing

 When maintaining these units and having such situations where personnel could be hurt by moving parts or by live electrical parts, the pump must be isolated by totally disconnecting the electrical supply. It is imperative that the unit cannot be re-started during the maintenance operation. Do not maintain a pump that is at its normal operating temperature as there is a danger from hot parts.

1. Lubrication (pictures 1 to 4)

The lubrication points are (L); lubrication periods are as follows, but the minimum is once a year:

Model	Operating hours		Grease every bearing
	50 Hz	60 Hz	
VTB 180	6.000	5.000	8 g
VTB 250	6.000	4.500	8 g
VTB 340	6.000	6.000	10 g
VTB 500	6.000	5.000	10 g

Note! These greasing instructions are valid for operation at 20°C ambient temperature. At 40°C these should be reduced by 50 %.

We recommend the following grease types: Klüber PETAMO GY 193 or other equal greases (see label of recommended greases (M)).

2. Air filtration (picture 5)

 The capacity of the pump may be reduced if the air inlet filters are not maintained correctly.

The filter cartridges (f) of the suction filter (S) have to be cleaned monthly and replaced once a year (under extreme conditions, more regularly). Changing the filter: Loosen thumb screws (g). Take off filter cover (h) complete with gasket. Remove filter cartridges (f) and clean or exchange. Re-assemble in reverse order.

3. Blades (pictures 3, 4 and 6)

Checking blades: The models VTB have 5 blades which have a low, but permanent, wear factor.

First check after 2,000 operating hours, thereafter every 500 operating hours.

Remove end cover (e). To remove the housing cover (b) from the housing the bolt (a) located in the centre of the bearing cover (c) should first be removed. To achieve this, one of the fixing bolts (s) from the housing cover should be screwed into the thread in the centre of the bearing cover (c). Remove the blades (d) and check. All blades must have a minimum height (X) of:

Model	X (minimum height)
VTB 180	40 mm
VTB 250	52 mm
VTB 340	57 mm
VTB 500	57 mm

 All blades must be changed at the same time.

Note! The VTB 500 has 2 blades per slot.

Changing blades: if the minimum height (X) is reached, then the whole set of rotor blades should be changed.

Before re-fitting the blades, blow out the housing and the rotor slots. Place the blades with the radius outwards (Y) such that the bevel is in the direction of rotation (O_1) and corresponds with the radius of the housing (Z).

Before re-fitting the housing cover (b), re-distribute the grease from the bearing cover (c) on to the appropriate bearing. It is important that the shaft end is completely clean so that no grease can enter the housing, as this could mix with carbon dust and give a viscous paste which would result in the blades becoming stuck in the rotor slots.

Note! Care should be taken that the bearing should not become contaminated.

When re-fitting the housing cover (b), tighten the bolts evenly so that the end cover fits correctly onto the fixing points. When the end cover is almost touching the housing we recommend moving the fan in both directions whilst further tightening the bolts. This can be achieved by removing the motor fan cover. This then ensures that the blades are sitting correctly in their slots and avoids any edge damage. Re-fit the end cover (e).

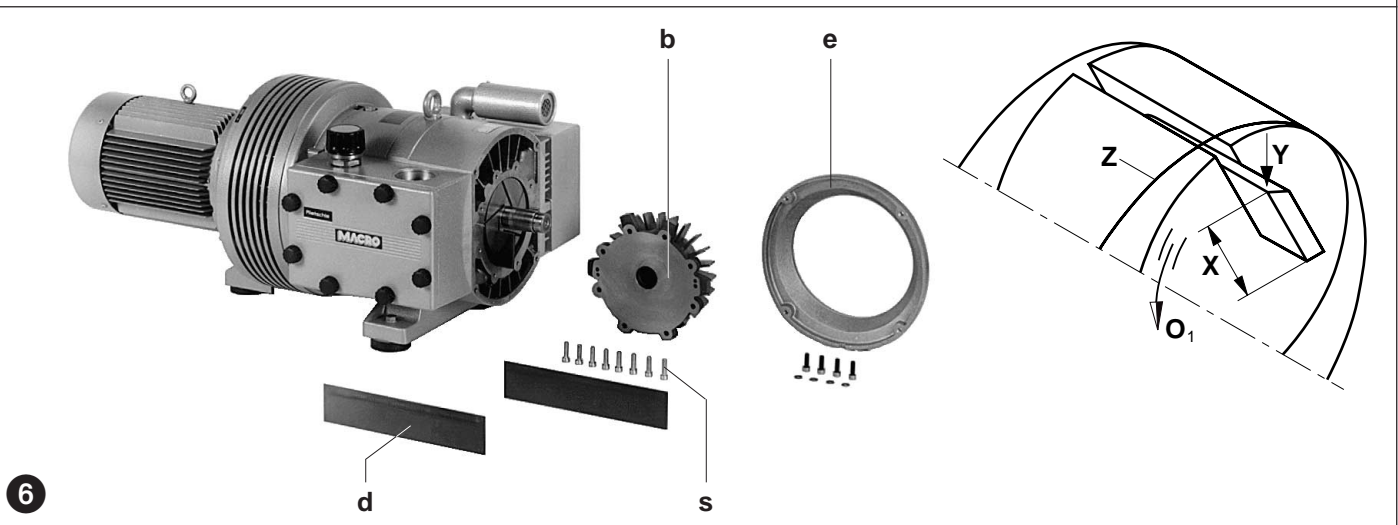
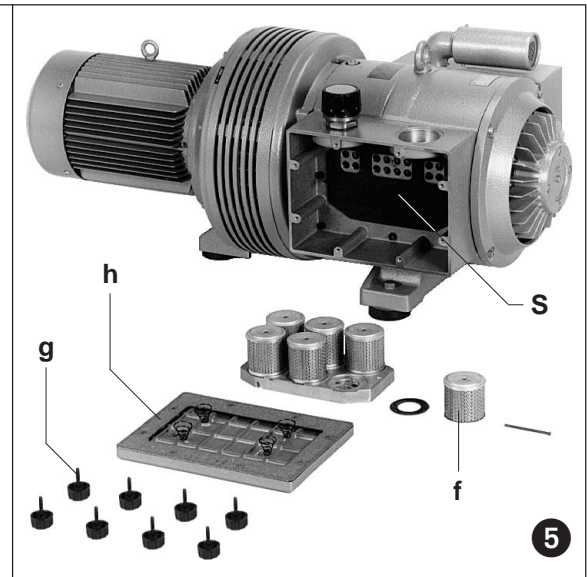

5. Coupling (picture 7)

The coupling rubbers (k) are wearing parts and should be checked regularly. When the coupling rubbers are worn this can be detected by a knocking sound when the vacuum pump is started.

⚠ Defective coupling rubbers can cause extensive damage and even in some extreme cases break the rotor shaft.

To check the coupling, stop the motor (m) and isolate. Remove the screws (s₅) on the motor flange (n). For motors secured by the feet, screws (s₆) should also be removed. Pull off the motor together with the motor side coupling half (q). If the coupling rubbers (k) are damaged, remove the circlips (l) from the coupling bolt (r) and exchange the coupling rubbers (k). Leave the spacer (p) in place, check the coupling bolts (r) for any wear and replace if necessary. To replace, remove the circlip (l₁), pull off the coupling and fan (v) complete from the pumpshaft, remove the nut (w) with washer (u) and exchange the coupling bolts. Re-assemble in reverse order.

Trouble Shooting:

1. Motor starter cuts out vacuum pump:

- 1.1 Check that the incoming voltage and frequency corresponds with the motor data plate.
- 1.2 Check the connections on the motor terminal block.
- 1.3 Pump is trying to operate against a closed exhaust or without an unloading valve on start/delta starting.
Solution: Optional extra, unloading valve model ZAE.
- 1.4 Incorrect setting on the motor starter.
- 1.5 Motor starter trips too fast.
Solution: Use a motor starter with a time delay trip (version as per IEC 947-4).
- 1.6 Back pressure on the exhaust pipework is excessive.

2. Insufficient suction capacity:

- 2.1 Inlet filters are obscured.
- 2.2 Suction pipe work is too long or too small.
- 2.3 Leak on the pump or on the system.
- 2.4 Blades are damaged.

3. Vacuum pump does not reach ultimate vacuum:

- 3.1 Check for leaks on the suction side of the pump or on the system.
- 3.2 Blades are worn or damaged.

4. Vacuum pump operates at an abnormally high temperature:

- 4.1 Ambient or suction temperature too high.
- 4.2 Cooling air flow is restricted.
- 4.3 Problem as per 1.6.

5. Unit emits abnormal noise:

- 5.1 The pump cylinder is worn.
Solution: send your complete unit off for repair to the supplier or approved service agent.
- 5.2 The regulating valve (if fitted) is noisy.
Solution: replace valve.
- 5.3 Blades are damaged.

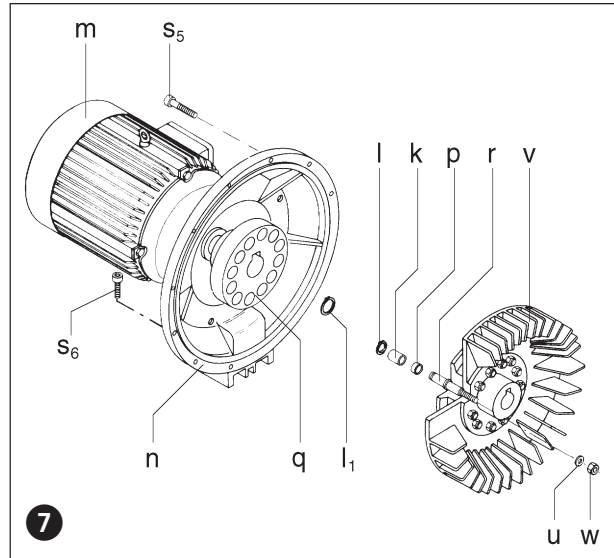

Appendix:

Repair on Site: For all repairs on site an electrician must disconnect the motor so that an accidental start of the unit cannot happen.

All engineers are recommended to consult the original manufacturer or one of the subsidiaries, agents or service agents. The address of the nearest repair workshop can be obtained from the manufacturer on application.

After a repair or before re-installation follow the instructions as shown under the headings "Installation and Initial Operation".

Lifting and Transport: To lift and transport the vacuum pump the eye bolts on the housing and motor must be used. If an eye bolt is missing use suitably rated strops. The weight of the pumps are shown in the accompanying table.

Storage: VTB units must be stored in dry ambient conditions with normal humidity. We recommend for a relative humidity of over 80% that the pump should be stored in a closed container with the appropriate drying agents.

Disposal: The wearing parts (as listed in the spare parts lists) should be disposed of with due regard to health and safety regulations.

Spare parts lists: E 267/1 → VTB 180 - VTB 500 (01)
E 267/2 → VTB 180 - VTB 500 (31)

VTB			180	250	340	500
Noise level (max.) / Sound power*	dB(A)	50 Hz	77	78	80	86 / 96*
		60 Hz	79	80	84	89 / 99*
Weight (max.)	kg	(01)	220	220	390	495
		(31)	230	230	410	515
Length (max.)	mm	(01)	1073	1073	1243	1444
		(31)	1072	1072	1243	1444
Width	mm		568	568	704	714
Height (max.)	mm	(01)	450	450	575	575
		(31)	647	647	807	807

VTB (01)		180			
m ³ /h	50 Hz	170			
	60 Hz	200			
mbar (abs.)					
3~	50 Hz	230/400 V ± 10%		400/690 V ± 10%	
	60 Hz	220/380 V		380/660 V	
kW	50 Hz	4,0	5,5	11,0	15,0
	60 Hz	4,8	6,5	13,0	18,0
A	50 Hz	16,9/9,8	14,5/8,4	22,5/13,0	30,0/17,3
	60 Hz	22,5/13,0	17,0/9,8	17,0/9,8	#
min ⁻¹	50 Hz	950			
	60 Hz	1140			
dB(A)	50 Hz	72	74	78	81
	60 Hz	75	76	82	83
kg		220	220	390	495
ZRV		25/0	25/0	50/0	50/0
ZRK / ZFP		65 (03) / 216 (51)	65 (03) / 216 (51)	80 (03) / 216 (52)	80 (03) / 216 (52)
ZVF	50 / 60 Hz	65 (02)	65 (02)	65 (03) / 100 (01)	100 (01)
ZMS	50 Hz	200/100	160/100	250/160	-/200
	60 Hz	250/160	200/100	-/160	#
ZAD / ZAE / ZBX	Baugrößen auf Anfrage / Size on request / Taille selon demande / Dimensioni su richiesta				

m ³ /h mbar (abs.) •	Saugvermögen Endvakuum (im Dauerbetrieb)	Capacity Ultimate vacuum (on continuous operation)	Débit Vide limite (en fonctionnement continu)	Portata Vuoto finale (in funzionamento continuo)
mbar (abs.)	Ansaugdruck	Suction pressure	Pression d'aspiration	Pressione di aspirazione
3~	Motorausführung	Motor version	Exécution moteur	Esecuzione motore
kW	Motorleistung	Motor rating	Puissance moteur	Potenza motore
A	Stromaufnahme	Current drawn	Intensité absorbée	Corrente nominale
min ⁻¹	Drehzahl	Speed	Vitesse rotation	Numero giri
dB(A) → DIN 45635	Mittlerer Schalldruckpegel	Average noise level	Niveau sonore moyen	Rumorosità media
kg	Max. Gewicht	Maximum weight	Poids maxi.	Peso massimo
ZRV	Zubehör	Optional extras	Accessoires	Accessori
ZRK	Vakuum-Regulierventil	Vacuum regulating valve	Valve réglage vide	Valvola regolazione vuoto
ZVF	Rückschlagventil	Non-return valve	Clapet anti-retour	Valvola di non ritorno
ZMS	Vakuumdichter Staubabscheider	Dust separator vacuum tight	Filtre séparateur étanche	Separatore polveri ermetico
ZAD	Vakuumdichter Ansaugfilter	Vacuum tight suction filter	Filtre d'aspiration étanche	Filtro aspirazione ermetico
ZAE	Motorschutzschalter	Motor starter	Disjoncteur moteur	Interruttore magnetotermico
ZBX	Sanftanlauf	Soft starter	Démarrage progressif	Soft starter
	Anlaufentlastung	Unloading valve	Décharge de démarrage	Avviamento a vuoto
	Schallbox	Acoustic enclosure	Caisson insonorisant	Box insonorizzante

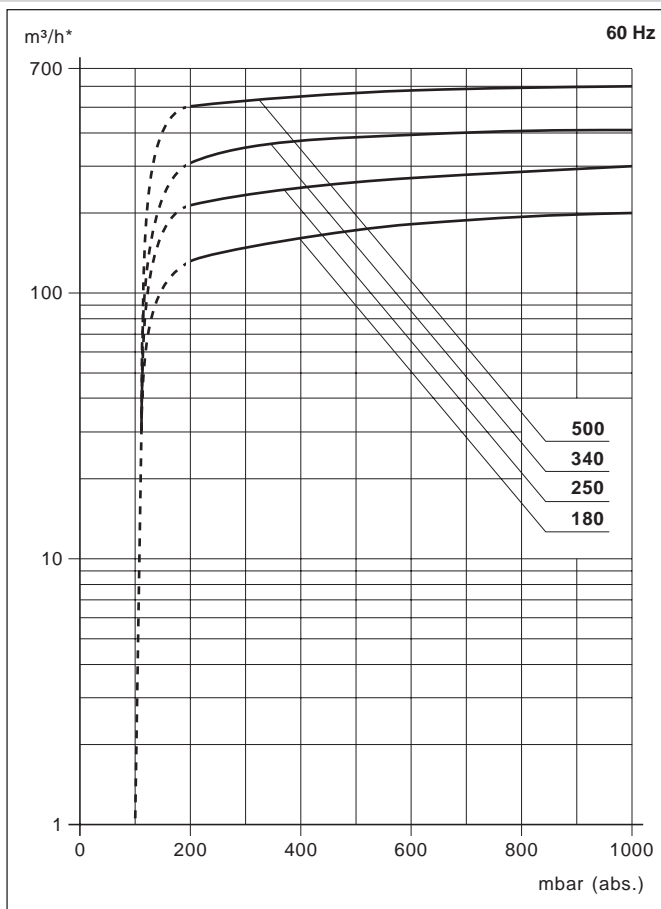
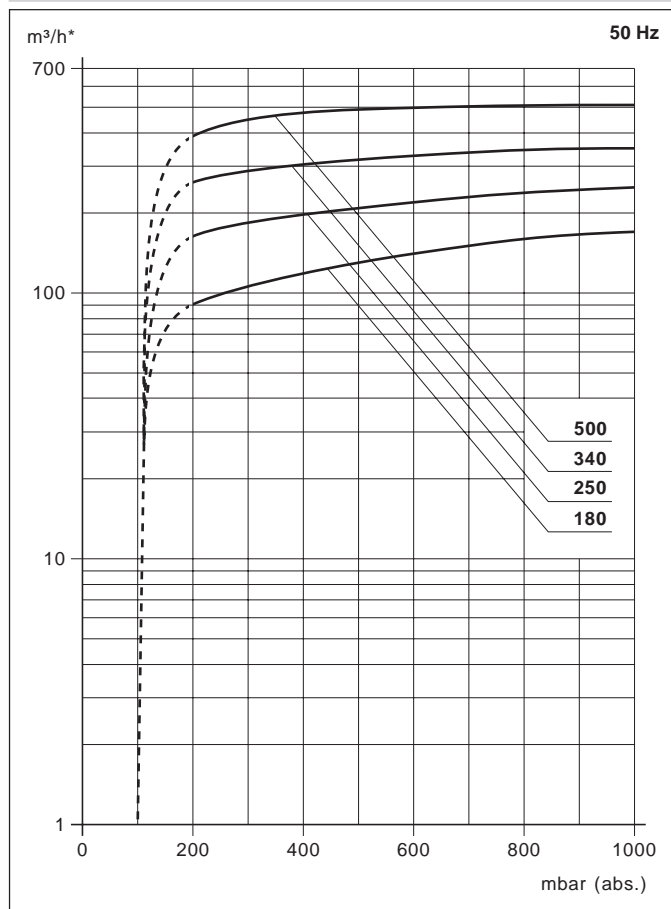

* bezogen auf den Zustand im Sauganschluß./ related to suction conditions at inlet connection./ relatif à l'état régnant à l'aspiration./ riferito alle condizioni in aspirazione.
 Kennlinien und Tabellenangaben beziehen sich auf betriebswarme Vakuumpumpen./ Curves and tables refer to vacuum pump at normal operating temperature./ Les courbes et tableaux sont établies, pompe à température de fonctionnement./ Le curve caratteristiche ed i dati riportati nelle tabelle si riferiscono alle pompe per vuoto con funzionamento a regime.
 Technische Änderungen vorbehalten! We reserve the right to alter technical information! Sous réserve de modification technique! Salvo modifiche tecniche!
 Die Abmessungen a und ø w sowie die Stromaufnahme können je nach Motorfabrikat von den hier aufgeführten Angaben abweichen./ The dimensions a and ø w and/or the current drawn can differ when compared with the data list, depending on the motor type./ Les dimensions a et ø w ainsi que l'ampérage peuvent différer des données indiquées ci-dessus, selon le fabricant du moteur./ Le dimensioni a e ø w come la corrente nominale possono scostarsi leggermente dai dati qui riportati a seconda del costruttore del motore.
 # auf Anfrage # on request # sur demande # a richiesta

VTB (01)		180	250	340	500
m ³ /h	50 Hz	170	250	350	510
	60 Hz	200	300	410	600
mbar (abs.)		200			
3~	50 Hz	230/400 V ± 10%		400/690 V ± 10%	
	60 Hz	220/380 V		380/660 V	
kW	50 Hz	4,0	5,5	11,0	15,0
	60 Hz	4,8	6,5	13,0	18,0
A	50 Hz	16,9/9,8	14,5/8,4	22,5/13,0	30,0/17,3
	60 Hz	22,5/13,0	17,0/9,8	17,0/9,8	#
min ⁻¹	50 Hz	950			
	60 Hz	1140			
dB(A)	50 Hz	72	74	78	81
	60 Hz	75	76	82	83
kg		220	220	390	495
ZRV		25/0	25/0	50/0	50/0
ZRK / ZFP		65 (03) / 216 (51)	65 (03) / 216 (51)	80 (03) / 216 (52)	80 (03) / 216 (52)
ZVF 50 / 60 Hz		65 (02)	65 (02)	65 (03) / 100 (01)	100 (01)
ZMS 50 Hz		200/100	160/100	250/160	-/200
ZMS 60 Hz		250/160	200/100	-/160	#
ZAD / ZAE / ZBX		Baugrößen auf Anfrage / Size on request / Taille selon demande / Dimensioni su richiesta			

m ³ /h	Saugvermögen	Capacity	Débit	Portata
mbar (abs.) •	Endvakuum (im Dauerbetrieb)	Ultimate vacuum (on continuous operation)	Vide limite (en fonctionnement continu)	Vuoto finale (in funzionamento continuo)
mbar (abs.)	Ansaugdruck	Suction pressure	Pression d'aspiration	Pressione di aspirazione
3~	Motorausführung	Motor version	Exécution moteur	Esecuzione motore
kW	Motorleistung	Motor rating	Puissance moteur	Potenza motore
A	Stromaufnahme	Current drawn	Intensité absorbée	Corrente nominale
min ⁻¹	Drehzahl	Speed	Vitesse rotation	Numero giri
dB(A) → DIN 45635	Mittlerer Schalldruckpegel	Average noise level	Niveau sonore moyen	Rumorosità media
kg	Max. Gewicht	Maximum weight	Poids maxi.	Peso massimo
ZRV	Zubehör	Optional extras	Accessoires	Accessori
ZRK	Vakuum-Regulierventil	Vacuum regulating valve	Valve réglage vide	Valvola regolazione vuoto
ZVF	Rückschlagventil	Non-return valve	Clapet anti-retour	Valvola di non ritorno
ZMS	Vakuumdichter Staubabscheider	Dust separator vacuum tight	Filtre séparateur étanche	Separatore polveri ermetico
ZAD	Vakuumdichter Ansaugfilter	Vacuum tight suction filter	Filtre d'aspiration étanche	Filtro aspirazione ermetico
ZAE	Motorschutzschalter	Motor starter	Disjoncteur moteur	Interruttore magnetotermico
ZBX	Sanftanlauf	Soft starter	Démarrage progressif	Soft starter
	Anlaufentlastung	Unloading valve	Décharge de démarrage	Avviamento a vuoto
	Schallbox	Acoustic enclosure	Caisson insonorisant	Box insonorizzante

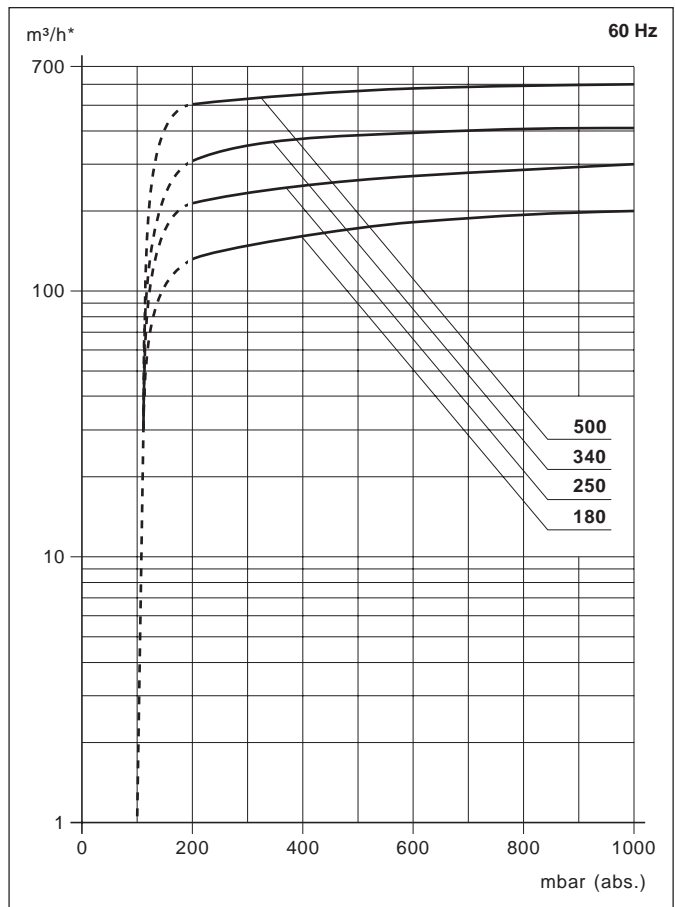
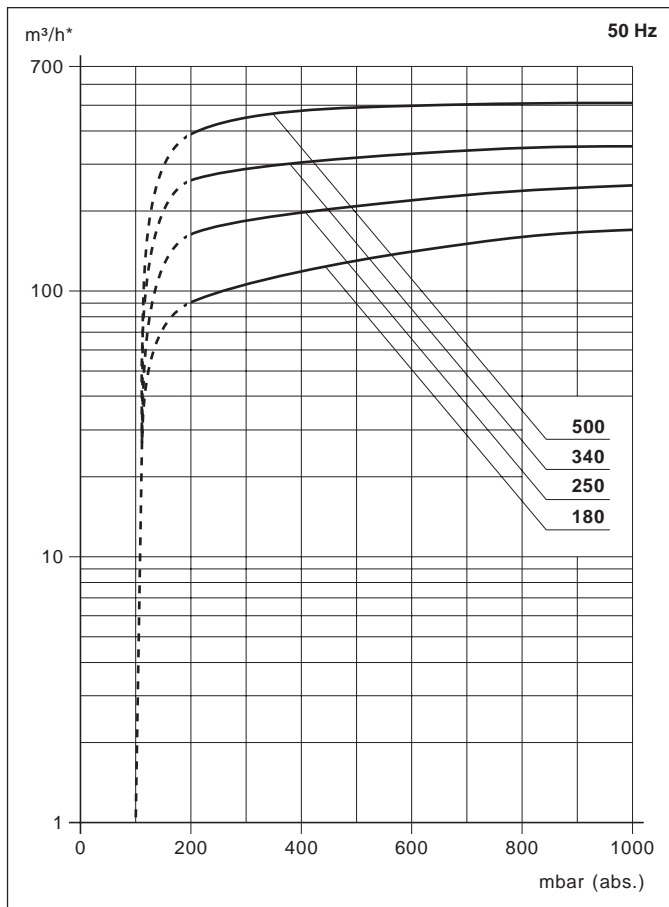

* bezogen auf den Zustand im Sauganschluß./ related to suction conditions at inlet connection./ relatif à l'état régnant à l'aspiration./ riferito alle condizioni in aspirazione.
 Kennlinien und Tabellenangaben beziehen sich auf betriebswarme Vakuumpumpen./ Curves and tables refer to vacuum pump at normal operating temperature./ Les courbes et tableaux sont établies, pompe à température de fonctionnement./ Le curve caratteristiche ed i dati riportati nelle tabelle si riferiscono alle pompe per vuoto con funzionamento a regime.
 Technische Änderungen vorbehalten! We reserve the right to alter technical information! Sous réserve de modification technique! Salvo modifiche tecniche!
 Die Abmessungen a und ø w sowie die Stromaufnahme können je nach Motorfabrikat von den hier aufgeführten Angaben abweichen./ The dimensions a and ø w and/or the current drawn can differ when compared with the data list, depending on the motor type./ Les dimensions a et ø w ainsi que l'ampérage peuvent différer des données indiquées ci-dessus, selon le fabricant du moteur./ Le dimensioni a e ø w come la corrente nominale possono scostarsi leggermente dai dati qui riportati a seconda del costruttore del motore.
 # auf Anfrage # on request # sur demande # a richiesta

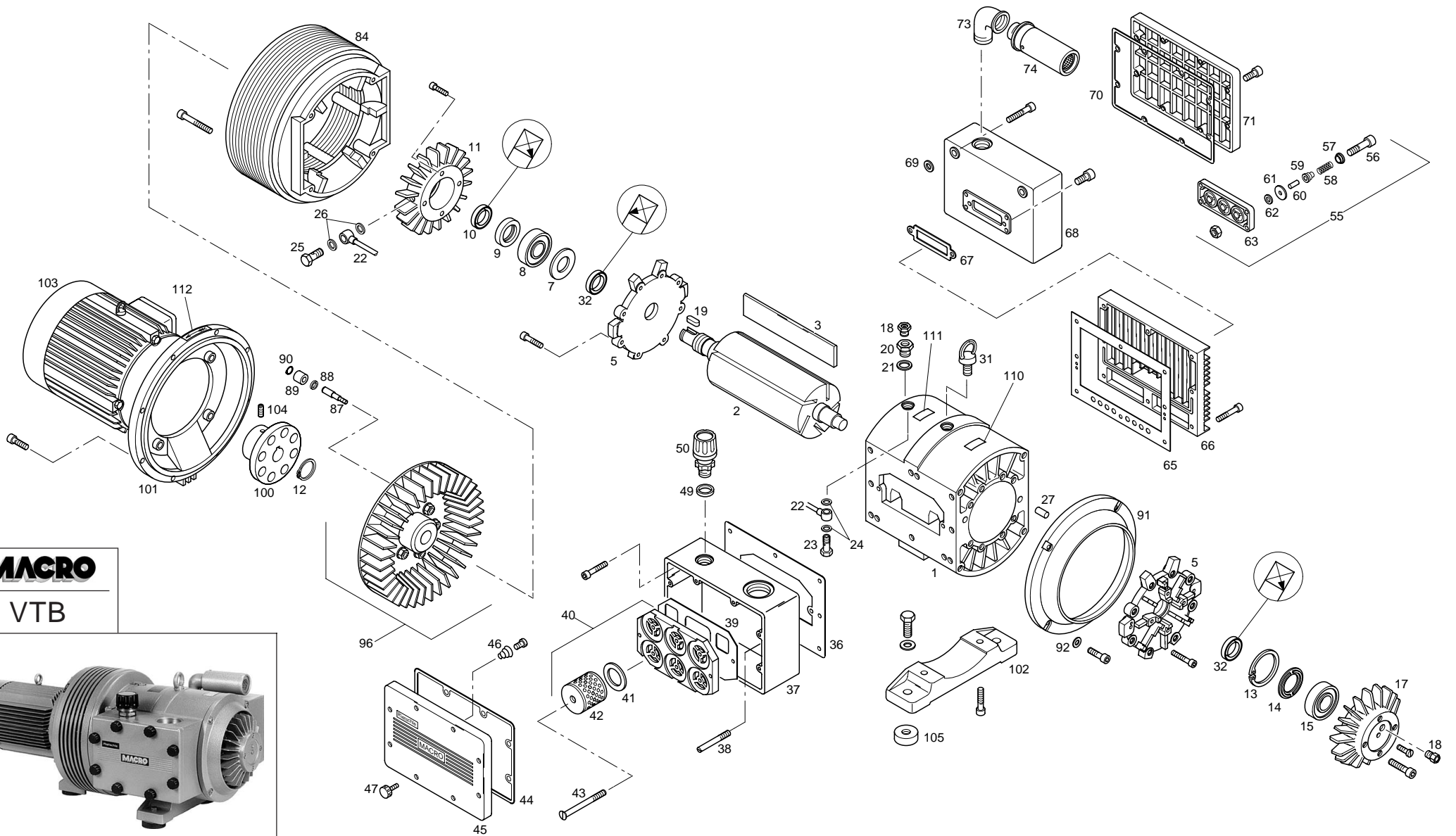

MACRO

VTB



	Grundeinheit	Basic unit	Unité de base	Elemento base					
1	Gehäuse	Housing	Corps	Corpo pompa	50	Vakuumbegrenzungsventil	Vacuum limitation valve	Limiteur de dépression	Valvola regolazione vuoto
2	Rotor	Rotor	Rotor	Rotore		Blasluftseite	Pressure side	Côté refoulement d'air	Lato soffieria
3	V Lamelle	Blade	Palette	Paletta	55	Ausblasventil komplett	Exhaust valve complete	Soupape refoulement cpl.	Valvola di scarico completo
5	Gehäusedeckel	Housing cover	Couvercle de corps	Coperchio corpo pompa	56	Innen-Sechskantschraube	Allen screw	Vis 6 pans creuse	Vite a brugola esagonale
7	Abdeckring' A	Cover ring' A	Cache' A	Anello di protezione' A	57	Federteller	Spring plate	Disque ressort	Piatto elastico
8	V Rillenkugellager	Deep groove ball bearing	Roulement aiguille	Cuscinetto a sfera	58	Druckfeder	Spring	Ressort	Molla a pressione
9	Spannmutter	Clamping nut	Ecrou tendeur	Manicotto di serraggio	59	Ventilkörper	Valve body	Corps valve	Corpo valvola
10	D INA-Dichtring	INA-seal ring	Joint d'arbre INA	Anello di tenuta INA	60	Rohr	Pipe	Tuyau	Tube
11	Lagerdeckel' A	Bearing cover' A	Couvercle de roulement' A	Coperchio cuscinetti' A	61	D Ventilscheibe	Valve disc	Rondelle valve	Rondella della valvola
12	V Sicherungsring	Lock ring	Circlip	Anello di sicurezza	62	Ventilscheibe	Valve disc	Rondelle valve	Rondella della valvola
13	V Sicherungsring	Lock ring	Circlip	Anello di sicurezza	63	Ventilplatte	Valve plate	Plaque valve	Piastra della valvola
14	Abdeckring' B	Cover ring' B	Cache' B	Anello di protezione' B	65	D Dichtung	Gasket	Joint	Guarnizione
15	V Zylinder-Rollenlager	Cylinder roller bearing	Roulement rouleaux cylindr.	Cuscinetto a rotolamento	66	Zwischenkasten	Intermediate box	Boîte intermédiaire	Scatola intermedia
17	Lagerdeckel' B	Bearing cover' B	Couvercle de roulement' B	Coperchio cuscinetti' B	67	D Dichtung	Gasket	Joint	Guarnizione
18	Trichterschmiernippel	Grease nipple	Graisneur	Ingrassatore	68	Ausblasgehäuse	Exhaust box	Carter refoulement	Scatola filtro
19	Paßfeder	Key	Clavette	Chiavetta	69	D Dichtring	Sealing ring	Anneau d'étanchéité	Anello di tenuta
20	Verschlußschraube	Lock plug	Bouche obturateur	Vite di chiusura	70	D Dichtung	Gasket	Joint	Guarnizione
21	Scheibe	Disc	Rondelle	Disco	71	Filterdeckel	Filter cover	Couvercle filtre	Coperchio del filtro
22	Rohrleitung	Pipe line	Tuyauterie	Tubazione	73	Bogen	Bend	Coude	Curva
23	Hohlschraube	Banjo bolt	Vis creuse	Vite forata	74	Geräuschdämpfer komplett	Silencer complete	Silencieux complet	Silenziatore completo
24	D Dichtring	Sealing ring	Anneau d'étanchéité	Anello di tenuta		Kühlung	Cooling	Refroidissement	Raffreddamento
25	Hohlschraube	Banjo bolt	Vis creuse	Vite forata	84	Ventilatorhaube	Fan cover	Capot ventilateur	Calotta del ventilatore
26	D Dichtring	Sealing ring	Anneau d'étanchéité	Anello di tenuta	87	Kupplungsbolzen	Coupling bolt	Plot d'accouplement	Perno del giunto
27	Zylinderstift	Dowel pin	Goujon cylindrique	Spina cilindrica	88	Distanzring	Spacer ring	Rondelle entre-toise	Anello distanziatore
31	Ringschraube	Lifting eye	Anneau de levage	Golfare	89	V Kupplungsgummi	Coupling rubber	Caoutchouc d'accoupl.	Gommino del giunto
32	D Wellendichtring	Shaft seal	Joint d'arbre	Anello di tenuta sull' albero	90	V Sicherungsring	Lock ring	Circlip	Anello di sicurezza
	Saugluftseite	Suction side	Côté aspiration	Lato aspirazione	91	Abschlußdeckel	End cover	Couvercle	Coperchio di chiusura
36	D Dichtung	Gasket	Joint	Guarnizione	92	Scheibe	Disc	Rondelle	Disco
37	Filtergehäuse	Filter housing	Carter filtre	Scatola del filtro	96	Ventilator/Kupplung kpl.	Fan/coupling cpl.	Ventilateur/accoupl. cpl.	Ventilatore/giunto compl.
38	Schaftschraube	Shaft screw	Vis calibrée	Vite prigioniera		Antrieb	Drive	Entraînement	Azionamento
39	D Dichtung	Gasket	Joint	Guarnizione	100	Kupplungshälfte treibend	Coupling half driving	Demi-accouplement moteur	Semigiunto lato motore
40	Papierfilter komplett	Paper filter complete	Filtre papier complet	Filtro in carta completa	101	Motorflansch	Motor flange	Bride moteur	Flangia motore
41	D Dichtring	Sealing ring	Anneau d'étanchéité	Anello di tenuta	102	Fuß	Foot	Socle	Piedistallo
42	V Micro-Top-Patrone.	Filter cartridge	Cartouche filtre	Cartuccia filtrante	103	Motor	Motor	Moteur	Motore
43	Senkschraube	Countersunk screw	Vis à tête conique	Vite a testa svasata	104	Gewindestift	Threaded pin	Vis pointeau	Spina filettata
44	D Dichtung	Gasket	Joint	Guarnizione	105	Fußpolster	Rubber foot	Plot antivibratoire	Piedini antivibranti
45	Filterdeckel	Filter cover	Couvercle filtre	Coperchio del filtro		Schilder	Labels	Plaques signalétiques	Targhette
46	Kegelfeder	Coil spring	Ressort	Molla conica	110	Datenschild	Data plate	Etiquette caractéristique	Targhetta dati
47	Filterschraubknopf	Filter knob	Tête molette	Pomello a vite	111	Schmierschilde	Greasing label	Etiquette graissage	Targhetta della lubrificazione
49	D Dichtring	Sealing ring	Anneau d'étanchéité	Anello di tenuta	112	Pfeilschild	Direction arrow	Sens de rotation	Freccia senso di rotazione

Bei Bestellungen folgendes angeben: Typ, Fabrikations-Nr., Positions-Nr., Motor (kW, V, Hz)

To order please indicate: model, serial-no., item-no., motor (kW, V, Hz)

En cas de commande préciser: type d'appareil, no. de position des pièces, moteur (kW, V, Hz)

Nell'ordine indicare: tipo, numero di matricola, numero di posizione dei ricambi, motore (kW, V, Hz)

V = Verschleißteile

V = Wearing parts

V = Pièces d'usure

V = Parti usurabili

D = Dichtungen

D = Seals

D = Joints

D = Guarnizioni

Werner Rietschle GmbH + Co. KG

Postfach 1260 • D-79642 Schopfheim

☎ 07622 / 392-0 • Fax 07622 / 392300

e-mail: info@rietschle.com