

Chemtech Scientific provides access to this content as a courtesy.
We do not own the content contained in this document.
All rights and credit go directly to its rightful owners.
www.chemtechsci.com
Call us at: 484-424-9415



Note: Please read the maintenance instructions given by the OEM for the machinery first. The OEM's manual should be adhered to in order to protect the equipment. Solberg Manufacturing, Inc has made every effort to make sure that these instructions are accurate but is not responsible for any typos, slight variations or for human errors that may occur.

Maintenance Manual

Solberg's Oil Mist Vacuum Discharge Eliminators

CONTENTS

Section A

Introduction pg. 3

Section B

General Information

1. Identification of Solberg Filters pg. 3
2. Filtration Rules of Thumb pg. 5
3. Element Specifications. pg. 6
4. Element Cleaning pg. 6

Section C

Procedures

1. Installation pg. 7
2. Disconnecting Canister Top From Base..... pg. 8
3. Removing Element for Service/Maintenance. pg. 8
4. Securing Element pg. 9
5. Securing Canister Top to Canister Base. pg. 9

Section D

Maintenance Recommendations

1. General pg. 10

**For Further Information Please Call: 630-773-1363*

Section A

INTRODUCTION

The purpose of this manual is instruction on the proper assembly and care of Solberg oil mist discharge filters.

WARNING

This manual must be read and thoroughly understood before using and caring for this exhaust filter. Failure to comply could result in explosion, product/system contamination or personal injury.

This manual should be used as a supplement to the user's understanding of the proper care needed to maintain a safe and dependable oil mist discharge filter. It is the responsibility of the user to interpret and explain all instructions to persons who do not read or understand English BEFORE they are allowed to maintain and use this exhaust filter.

This manual should be readily available to all operators responsible for operation and maintenance of the oil mist exhaust filters.

We thank you for selecting products from Solberg Manufacturing, Inc. We are confident that our superior filter designs will meet your application requirements.

Section B

GENERAL INFORMATION

1. Identification of Solberg Oil Mist Discharge Filters.

All Solberg oil mist discharge filters should have an identification label/nameplate that gives the following information:

Assembly Model #
Replacement Element #

(The exception is OEM supplied units. In this case please enter their part numbers below.)

Fill in the actual nameplate data from your Solberg oil mist discharge filter(s):

No.	Filter Model Number	Replacement Element
1		
2		
3		
4		
5		

Table 1

The model number designates the filter type, the original element configuration and housing connection size. For example, the following part number identifies the filter as being a 'HDL' design filter with a PSG344/2 element and 3" MPT connection size:

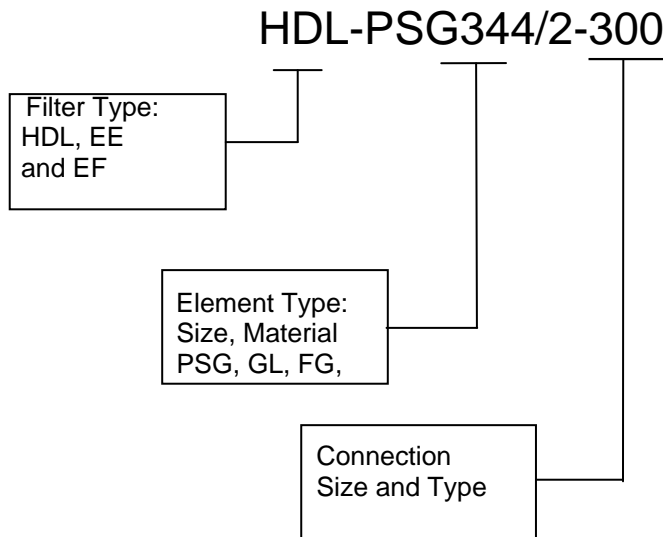

2. Filtration Rules of Thumb

General: For peak output performance from a compressor, blower, vacuum pump, engine, or any other machine that consumes air, one must have clean, unrestricted air on the inlet and discharge. Proper filtration can help stabilize the working environment within rotating equipment even when the external conditions may be quite severe. A critical component in creating the right

working conditions is filter sizing. With the properly sized filter, equipment will run smoothly over its entire expected operating life.

A major factor in filtration and filter sizing is air velocity through the filter media. Generally, the slower the velocity of air through a media the higher the filter efficiency and, conversely, the lower the pressure drop. Therefore, the primary goal in filter sizing is to optimize the velocity of air through the media (sometimes called face velocity).

Recent developments in product design allow for the possible selection of oil mist discharge filters based on the type of equipment being used. It is, for the first time, possible to identify the appropriate grade of aerosol discharge filter because of the extensive research completed by the Solberg R&D Department. Please follow the below rules to correctly size your oil mist discharge filter. If further consultation is required, please contact Solberg.

Rule of Thumb #1: Forget all that you know about air/oil separators for Compressed Air Systems, as such systems repeatedly fail in vacuum pump applications. The first consideration is to determine the type of vacuum pump or machine being used. The particle size distribution and mass of oil aerosol discharging from a vacuum pump is as varied as the number of separator tank designs utilized by industry. The primary pump technologies in need of air/oil separation are rotary vane, rotary screw, rotary piston, liquid ring, and reciprocating. Each type of pump produces its own specific oil discharge characteristics and requires the appropriate media make-up to effectively capture and drain oil aerosols.

Rule of Thumb #2: Determine the type of oil being used in the vacuum pump. Trade names, viscosity/grade of oil, and the lubricant base (mineral, synthetic, etc.) are all useful in determining the discharge aerosol characteristics.

Rule of Thumb #3: Determine how much oil the pump consumes under normal operating conditions. Typical consumption rates are gallons or liters per hour. The amount of oil consumed is typically the amount of oil being discharged.

Rule of Thumb #4: Determine pump operating cycles including vacuum range, temperature fluctuations, contaminant gases or vapors, and hours of operation per day/week. Also, determine the maximum pressure drop or filter restriction the system will allow.

Rule of Thumb #5: Note the horsepower of the pump, the outlet connection, and the nominal capacity.

Rule of Thumb #6: When an external unit is to be used as the primary or sole air/oil separator in a system, a multi-stage severe duty system is required.

Rule of Thumb #7: In the case where an existing air/oil separator (internal or external) is already used, it is important to specify the desired goal for a second filter. Is it planned to have a multi-staged system for severe or extreme duty applications, or is there a requirement for exceptionally clean discharge air? If a multiple stage system is needed, try to identify the primary stage unit and the purpose for the second stage.

Once as much information as possible is obtained, send the data to Solberg Manufacturing, Inc. for our review and/or review our data sheets in the Product-by-Product Line section of our web page. You'll find our data sheets under "Oil Mist Eliminators".

Pipe Size (inches)	Max Airflow		Pipe Size (inches)	Max Airflow		Pipe Size (inches)	Airflow	
1/4"	6 CFM	10m ³ /h	1 ¼"	60 CFM	102m ³ /h	6"	1,100 CFM	1870m ³ /h
3/8"	8 CFM	14m ³ /h	1 ½"	80 CFM	136m ³ /h	8"	1,800 CFM	3060m ³ /h
1/2"	10 CFM	17m ³ /h	2"	135 CFM	230m ³ /h	10"	3,300 CFM	5610m ³ /h
3/4"	20 CFM	34m ³ /h	2 ½"	195 CFM	332m ³ /h	12"	4,700 CFM	7990m ³ /h
1"	35 CFM	60m ³ /h	3"	300 CFM	510m ³ /h	14"	6,000 CFM	10200m ³ /h
			4"	520 CFM	884m ³ /h			
			5"	800 CFM	1360m ³ /h			

Table 2 **Note: This information is for general use only. A qualified engineer must properly design each system.*

3. Element Specifications
Media: PSG, GL, FG, CEG, WG

Efficiency: 99.97% @ 0.3 micron
 Typical Element Operating Pressure: 0 – 5 psig / 0 – 0.36 BAR
 Filter Change-Out Differential: 2.5 psid / 0.36 BAR over initial backpressure of the saturated element

4. Element Cleaning

Cleaning is not recommended for Solberg Manufacturing oil mist discharge filter elements. Once saturation and particulate entrainment occur, it is very difficult to restore elements to their original condition. It is recommended that once maximum differential pressure is reached new elements should be installed.

Section C

PROCEDURES

WARNING

Before installing any Solberg filter, it is essential that all packaging materials be removed properly, prior to start up, to avoid risk of injury.

1. Installation.

- A. Direction of flow is typically from the inside of the element to the outside of the element. Most products have arrows indicating direction of flow on inlet and outlet ports.
- B. Ensure that pipe/flange connections are adequately sealed so the potential for leaks is reduced to a minimum.
- C. Mounting orientation is typically top-up vertical so draining can occur.



Preferred Installation Method

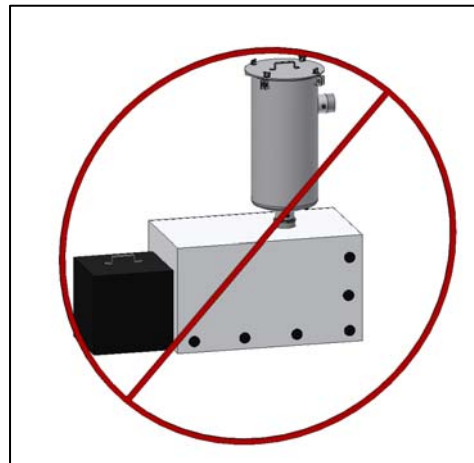

Improper Installation Method

- D. Each Solberg Oil Mist Eliminator is equipped with a plugged drain port on the bottom side of the filter canister. Before operating, please ensure that the port is unplugged and a drain line is added for oil recovery. If the plug is not removed and a drain line is not added, oil will collect in the filter canister and will eventually carryover through the canister outlet. The result is visible oil mist contamination into the surrounding atmosphere. Please call Solberg Manufacturing, Inc. with any installation questions.

2. Disconnecting canister top from canister base.

- A. Remove fastener.
 - 1. EF: Loosen thumbscrew and remove canister top.
 - 2. EE: Twist off canister top.
 - 3. Small HDL (1" to 1 ½"): Loosen wing nut on hinged bolts.
 - 4. Small HDL (2" to 2 ½"): Loosen hex nut on V-band T-bolt.
 - 5. Large HDL: Loosen hex nut on T-bolt.
- B. Lift off canister top.

3. Removing element for service/maintenance.

- A. On EF models, element will be free when canister top is removed. All other models have a retaining bolt and element top plate. Remove retaining bolt and washer, and then carefully remove top plate. **Ensure that nothing falls into piping when element is removed!** Remove element.
- B. Clean sealing surfaces of housing, top plates and new element end-caps so that they are free of dirt or any other particulate.

WARNING

**Failure to comply with these instructions
may result in system or pump contamination.**

4. Securing Element.

- A. Place new element evenly on base plate. Be sure element seats properly on base and there is no dirt or particulate present on sealing surfaces.
- B. Place top plate (if necessary) on element.
- C. Secure washer and thumb/wing/hex bolt to element top plate and tap bolt. Element must be tightly secured. Note: Do NOT over tighten!

WARNING

Defective installation may cause system or pump contamination. Use only genuine Solberg replacement parts.

5. Securing canister/housing top to canister base.

- A. Make sure all surfaces are free from dust and other particulate.
- B. O-rings (where necessary) must rest evenly along canister/housing base o-ring groove.
- C. EE: Insert and tighten thumb screw on element. Place canister top cover over element and twist.
- D. EF: Place canisters top over element and insert and tighten thumbscrew.
- E. Small HDL (2"-2 ½"): Secure V-clamp by disconnecting hex nut or T-bolt portion and placing V-clamp along the diameter of canister o-ring groove. Fasten T-bolt and secure tightly. V-CLAMP LEGS MUST REST UNIFORMLY ALONG ENTIRE O-RING GROOVE.
- F. Large HDL: Replace housing top plate. Insert T-bolts into corresponding holes and tighten evenly around perimeter. Note: Do NOT over tighten!

Section D

MAINTENANCE RECOMMENDATIONS

1. Initial back pressure readings are recommended to maintain an effective oil mist filter. Always document initial back pressure during start-up when element is clean and after two weeks when element is saturated. Replacement cartridge is needed when system experiences high back pressure. Refer to page 6 for guidelines.
2. Always check replacement o-rings to insure they are seated uniformly along the canisters/housings during installation. If o-rings do not seat properly or are damaged in some manner, contact Solberg Manufacturing, Inc. immediately. Do not modify or change o-rings!
3. Always check inlets/outlets, element base and its components when replacing element to insure cleanliness. Wipe clean if necessary.
4. Operate only when a proper seal exists.
5. Never operate without absolute assurance that V-clamp is secured correctly along entire diameter of canisters (where used). Check along V-clamp for wear. Replace if any distortion occurs due to handling and usage.