

# MICROVAC PUMP OPERATING INSTRUCTIONS

MICROVAC PUMP  
OPERATING INSTRUCTIONS

SERIAL NO

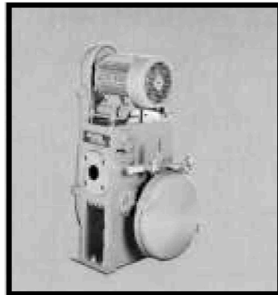

MODEL 146-H13  
MICROVAC PUMP



MODEL 148-H10  
MICROVAC PUMP



MODEL 149-H11  
MICROVAC PUMP



MODEL 212-H11  
MICROVAC PUMP



MODEL 412-H11  
MICROVAC PUMP



Rev. 1.0  
9-98

ISO 9001  
QUALITY SYSTEM  
CERTIFIED  
ACCREDITED BY THE  
DUTCH COUNCIL  
FOR CERTIFICATION  
1994

---

---

**NOTE:**

**"THE INFORMATION HEREIN SHALL BE TREATED IN THE  
STRICTEST CONFIDENCE,  
AND SHALL NOT BE  
DISCLOSED TO ANY THIRD PARTY WITHOUT THE PRIOR  
WRITTEN PERMISSION OF  
STOKES VACUUM, INC.**

**THIS INFORMATION SHALL BE USED SOLELY FOR THE  
PURPOSE FOR WHICH IT HAS BEEN SUPPLIED AND FOR  
NO OTHER PURPOSE  
WHATSOEVER."  
STOKES VACUUM, INC., PHILADELPHIA, PA**

---

---

---

| <b>Section</b>                                 | <b>Page</b> |
|--|-------------|
| <b>1.0 DESCRIPTION</b>                         |             |
| 1.1 General                                    | 1-1         |
| 1.2 Gas Ballast                                | 1-1         |
| 1.3 Water System                               | 1-2         |
| 1.4 Electrical System                          | 1-2         |
| 1.5 Lubricants                                 | 1-2         |
| 1.6 Guards                                     | 1-2         |
| 1.7 Vacuum Break & Gage Ports                  | 1-2         |
| <b>2.0 INSTALLATION</b>                        |             |
| 2.1 Locating and Mounting                      | 2-1         |
| 2.2 Vacuum Piping                              | 2-1         |
| 2.3 Exhaust Piping                             | 2-2         |
| 2.4 Electrical Connections                     | 2-3         |
| 2.5 Cooling                                    | 2-4         |
| 2.6 Lubrication of Pump                        | 2-4         |
| <b>3.0 OPERATION</b>                           |             |
| 3.1 Pre-Start Check                            | 3-1         |
| 3.2 Pump Start                                 | 3-2         |
| 3.3 Checking Oil Level                         | 3-2         |
| 3.4 Operation of Gas Ballast                   | 3-2         |
| 3.5 Pump Stop                                  | 3-3         |
| 3.6 Operating Notes                            | 3-4         |
| <b>4.0 CHECKING</b>                            |             |
| 4.1 Poor Vacuum                                | 4-1         |
| 4.2 Localizing Leakage                         | 4-1         |
| 4.3 Repairing Small Leaks                      | 4-1         |
| 4.4 Pump Activity Record                       | 4-2         |
| <b>5.0 TROUBLESHOOTING GUIDE</b>               | <b>5-1</b>  |
| <b>6.0 SPECIFICATIONS AND PARTS LIST</b>       |             |
| <b>7.0 MAINTENANCE</b>                         |             |
| <b>8.0 STOKES SUPPLEMENTARY DATA</b>           |             |
| Parts Ordering Information                     |             |
| Recommended Replacement Parts Kit              |             |
| Stokes Microvac 2-Year Warranty                |             |
| Pumping Hazardous Gases Sheet                  |             |
| Pumping Fluids, Lubricants and Grease Bulletin |             |

---

---

# **BULLETIN**

**CHECK YOUR MICROVAC PUMP  
RESERVOIR SIGHT GLASS GAGE TO SEE IF  
YOUR PUMP WAS SHIPPED WITH AN  
INITIAL CHARGE OF OIL AND/OR IF THE OIL  
WAS SHIPPED IN SEPARATE  
CONTAINERS.  
REFER TO PAGE 2-4 INITIAL FILL**

---

1.0 DESCRIPTION

1.1 GENERAL (Principle of Operation)

The Stokes Microvac Pump is a self-contained, rotary, oil sealed piston type unit. The piston is driven by an eccentric mounted on the drive shaft and the piston slide is guided by two floating hinge bars that are free to oscillate in the pump housing. Facing the drive end, the piston assembly rotates clockwise. Air enters the pump through the intake and then through the piston slide until the piston completes its stroke. At this point all air previously entrapped is in front of the piston as it begins another stroke. As the piston continues to rotate, the air in front of it is compressed and discharged through the exhaust valve and finally out the exhaust outlet. As the piston nears the top center position the intake port is closed, separating the system from the pump (See Figure 1). The exhaust valves are of the corrosion-resistant, heavy duty, poppet type. When the pump is in operation, lubrication of the internal parts is completely automatic. Oil is forced by atmospheric pressure from the reservoir through the oil lines to the shaft bearings. The oil is then fed into the pump to provide the necessary piston-to-cylinder oil seal. Finally, the oil is forced out through the exhaust valve with the air and returns to the reservoir. A solenoid valve automatically prevents oil from flooding the pump in the event of a power failure, or when the pump is accidentally shutdown without vacuum being broken.

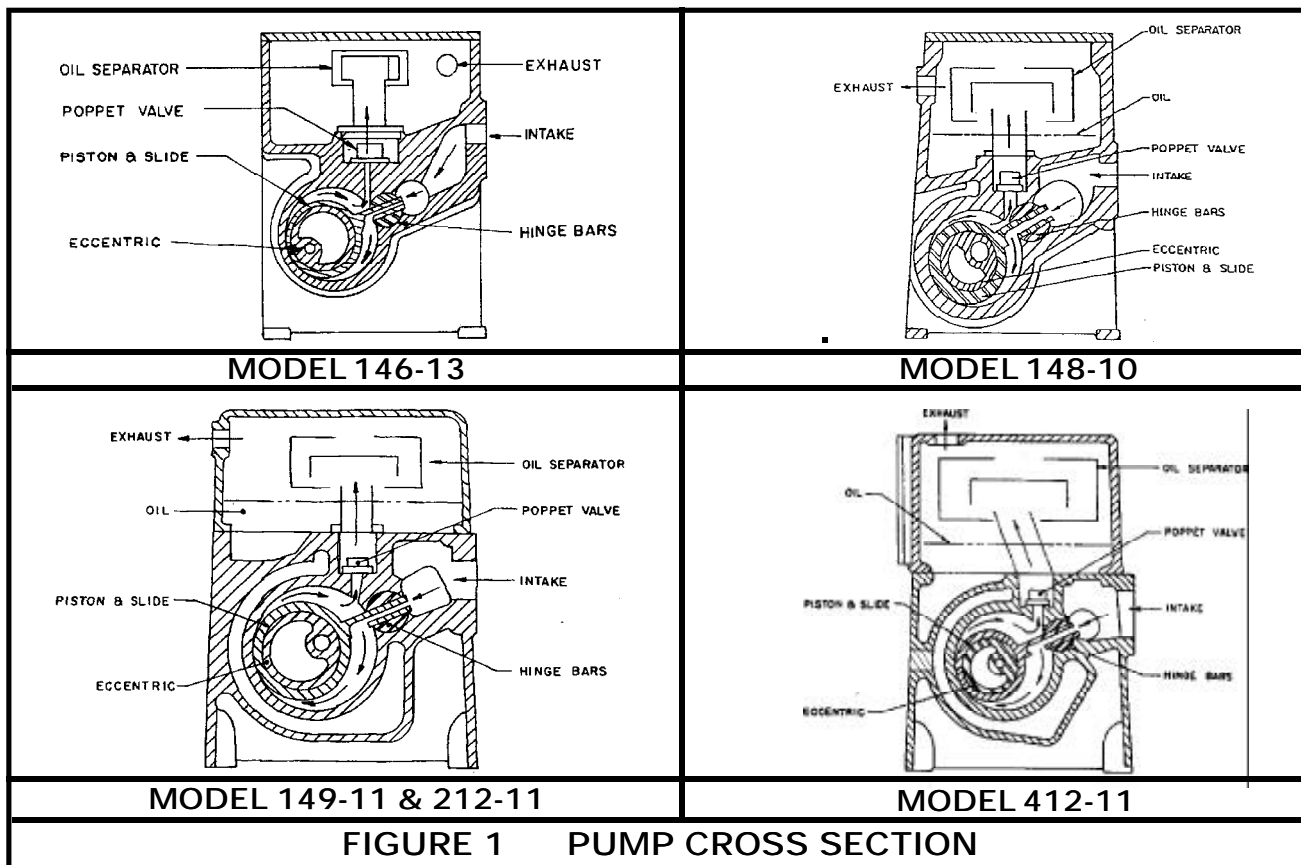

1.2 GAS BALLAST

The pump is provided with a manually operated gas ballast valve to overcome the adverse affect on vacuum resulting from oil contamination. Contamination occurs when water vapor or other gaseous components enter the pump and condense within the pump mixing with the oil as emulsified droplets. The condensate will mix with the oil and "flash" into vapor again as the oil circulates into high vacuum in the pump cylinder limiting the vacuum to the vapor pressure of the condensed water. Gas Ballast is a controlled bleed of air from the atmosphere. This air carries the water vapor through the compression cycle without it condensing to liquid and mixing with oil. Thus, the water vapors are exhausted without contaminating the pump oil. Other contaminates are also removed by ballasting except those that dissolve in the oil.

## STOKES VACUUM MICROVAC® VACUUM PUMP

**NOTE:** Never use gas ballast when pumping gases or gas mixtures that are explosive or flammable.

### 1.3 WATER SYSTEM (149-11, 212-11, 412-11 ONLY)

A supply of cooling water at 85° F. and \* G.P.M. maximum is needed at the water inlet for efficient performance. See Section 2.5 for additional information.

|          |                   |
|----------|-------------------|
| *149-011 | 1 GPM MAXIMUM     |
| *212-011 | 1-1/2 GPM MAXIMUM |
| *412-011 | 2 GPM MAXIMUM     |

### 1.4 ELECTRICAL SYSTEM

The main power supply is 230/460V., 60 Cy., 3 Ph. and should be wired through a suitable fused motor starter. Power for the oil solenoid is taken from any two of the motor leads. Check both motor and solenoid nameplates to insure proper voltage.

### 1.5 LUBRICANTS

Refer to Section 2 for recommended high vacuum grease and pumping fluids.

### 1.6 GUARDS

The standard pump is with a totally enclosed belt guard to cover the motor pulley, pump pulley and belts.

146, 148, 149 **NOTE: ALSO ENCLOSED FLYWHEEL GUARDS ARE INCLUDED AS STANDARD EQUIPMENT.**

### 1.7 VACUUM BREAK & GAGE PORTS

The pump is provided with a: 146-13 & 148-10 1/4" FPT Gage Port; 149-11, 212-11 & 412-11 1/2" FPT Vacuum Break & a 1/4" FPT Gage Port, as shown in Fig. 11.

**IMPORTANT:** When using Gage Port, provided a 90° elbow and at least 12" of vertical pipe to the gage sensor.

## 2.0 INSTALLATION

### 2.1 LOCATING AND MOUNTING

Locate the pump as near as possible to the equipment being evacuated so that the Vacuum, Water and Exhaust connections can be conveniently made. Provide for adequate space for convenient servicing where possible.

2.1.2 The pump should be mounted on a rigid foundation, such as a concrete floor, and made level by shimming or grouting, if necessary. Bolt pump to foundation without putting a strain or twist in the pump housing. See Figure 12 for foundation bolting dimensions.

2.1.3 Remove cap from exhaust and intake openings only when ready to make a pipe connection. Also remove the plastic plug (by unscrewing) from the Gas Ballast valve. When pump is to be subjected to temperatures below freezing, drain water jacket through the housing drain plug to prevent cracking the housing, then blow out water jacket. Follow this same procedure for storage.

### 2.2 VACUUM PIPING

**Be sure all vacuum piping is tight.** All pipe lines should be as short as possible and should be no smaller than the inlet to the pump. (If it is absolutely necessary to run a long line, the pipe size should be increased 50% in diameter, or more, than the inlet to the pump.) Conductance of long lines must be checked and the line sized large enough or pumping speed of system will be seriously decreased. When connecting pump to the system, provide a vertical pipe at least 2 ft. long between the pump and the system, if the pump is below the system inlet. If the pump is above or level with the system inlet, provide an inverted "U" pipe to serve as a trap for dirt from the system and to prevent migration of pump oil toward the system inlet. Be sure all vacuum piping is tight. If an inline filter is being used it should be installed as noted below. It is advisable to install a flexible connection between pump intake and vacuum piping to eliminate vibration. (See Figures 2 & 3).

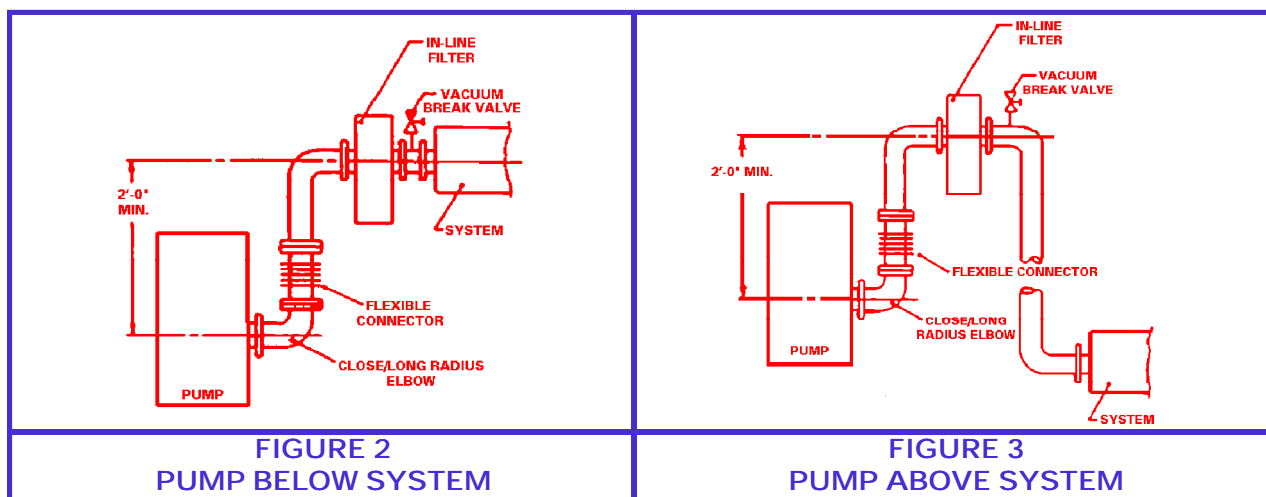

A high vacuum valve (full opening type preferred) is recommended to facilitate start-up and for checking pump blank off pressure.

**CAUTION:** Make sure the system to be evacuated and connecting lines are clean and free of weld splatter, dirt, or grit. Foreign matter entering the pump can cause failure and possibly damage the internal parts. To prevent this it is recommended that a 16 mesh wire screen be installed at the inlet connection. After 20 hours of operation the screen must be removed.

### 2.2.1 TYPES OF PIPING JOINTS

- A. Standard wrought piping with welded joints makes the best vacuum piping system.
- B. Copper piping with sweated fittings and joints can also be made vacuum tight and has the advantage of providing a neat, clean vacuum installation.
- C. Standard threaded piping, however, is satisfactory and more readily installed. The piping should be carefully hammered to loosen any scales or chips. Blow out the resultant with compressed air prior to installation. All male threaded joints should be carefully doped, screwed up tight and NEVER "backed-off" to make parts align - this is apt to cause a leak. Paint the joints while the system is under vacuum until the paint is no longer drawn in, G.E. 1201-B, Glyptal or equivalent is recommended for painting all connections.

### 2.2.2 LOCATION OF GAGE PORT

A vacuum gage connection is located at the upper left hand side of intake side of pump. (See Figure 12). The pipe plug found at this location should be replaced with a small vacuum ball valve to which the gage can be connected. When a Stokes McLeod Gage is used a synthetic, thick wall, smooth bore tubing, such as Tygon, makes a very satisfactory flexible connection.

### 2.3 EXHAUST PIPING

2.3.1 It is recommended that the exhaust be piped horizontally as short distance and tied into a vertical exhaust pipe. The vertical exhaust pipe must be at least 1 ft. (12 inches) long and the bottom end of the vertical exhaust pipe terminated with a plug or a drain cock to allow removal of moisture and contaminated oil before it can accumulate sufficiently to drain back into pump oil reservoir. See Figure 4.

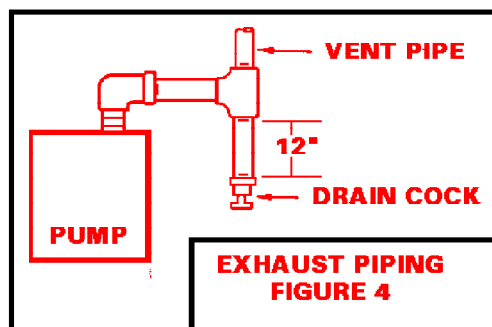

2.3.2 The exhaust pipe should be no smaller than the exhaust outlet and as short as possible. Run the pipe outside the building where the pump exhaust vapors will not be objectionable. Point the outside end of the exhaust pipe downward to prevent the entrance of rain water.

2.3.3 Closed circuit Oil Mist Separators are available from Stokes which can eliminate oil fog in the majority of applications. The separator will not remove noxious or toxic gases and must be run outside the building. For operating continually under conditions of higher pressure an electro-static precipitator is recommended. Contact Stokes for specifics.

**CAUTION: NEVER PLACE A VALVE IN THE EXHAUST LINE. IF A VALVE MUST BE INSTALLED IN THE LINE, A RELIEF VALVE MUST ALSO BE INSERTED IN THE LINE BETWEEN THE RESERVOIR AND THE VALVE. THE RELIEF VALVE SHOULD BE EQUAL IN SIZE TO THE LINE, AND SET TO OPEN AT 2 PSIG.**



# STOKES VACUUM MICROVAC® VACUUM PUMP

## 2.4 ELECTRICAL CONNECTIONS (See Figure 5)

**CAUTION: BE SURE PUMP IS PROPERLY LUBRICATED BEFORE STARTING.**

- 2.4.1 Install a motor starter with safety device within easy reach of the operator.
- 2.4.2 Connect the solenoid valve as in Figure 5.
- 2.4.3 Connect motor so that pump shaft rotates clockwise when viewed from driven end. See 3.1 for Pre-Start Check.

**NOTE: MAKE SURE THE PROPER VOLTAGE, STARTERS AND OVERLOADS ARE SUPPLIED TO THE MOTOR. MAKE SURE THAT THE SOLENOID COIL LEADS ARE CONNECTED FOR PROPER VOLTAGE. BOTH MAY FAIL TO OPERATE IF VOLTAGE IS LESS THAN 90% OF RATED.**

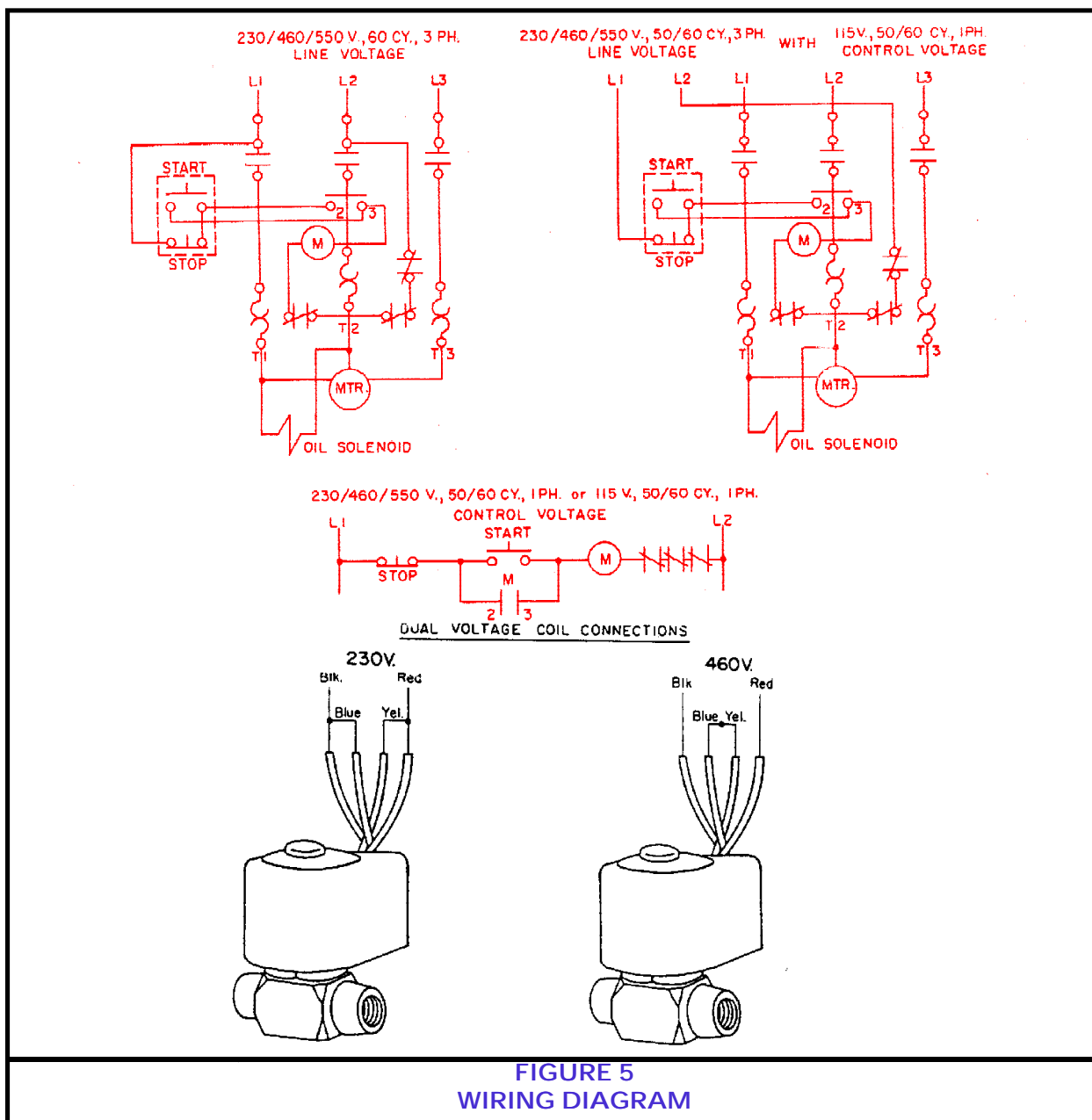

FIGURE 5  
WIRING DIAGRAM

## 2.5 COOLING

**FOR PUMP MODELS 146-13 AND 148 -10 USE 2.5.1 THAT FOLLOWS. FOR 149-11, 212-11, AND 412-11 USE 2.5.1 THRU 2.5.5.**

2.5.1 This pump is air cooled and no water connections are necessary.

### **149-11, 212-11 & 412-11 ONLY**

2.5.1 This pump is water cooled and must be connected to a water supply.

2.5.2 The 1/2" water inlet connection is located in the pump housing on the drive side near the bottom.

2.5.3 Insert a valve in the water inlet line and regulate the water flow so that the temperature of the oil in the reservoir is between 140 Deg. and 160 Deg. F. Oil temperature kits are available that automatically control the water flow to maintain the proper oil temperature (Consult factory). If pump is outside and subjected to freezing temperatures, water tank and circulating pump should be installed with anti-freeze in the water.

**CAUTION: DO NOT START PUMP WHEN OIL TEMPERATURE IS BELOW 55° F.**

2.5.4 The 1/2" water outlet is located in the pump housing on the opposite side of the water inlet.

2.5.5 The water outlet **SHOULD** be connected to an open drain to permit the operator to check the flow and temperature of the outlet water periodically. There **SHOULD NOT** be a valve or back pressure in this line. In some cases, cooling water must be discharged to a pressure drain. In such cases, discharge pressure must not exceed 50 P.S.I.G. and no block valve should be placed in discharge line unless a 50# relief valve is provided to protect pump from high inlet pressure.

**NOTE: IF CONDENSABLES ARE PRESENT IN GAS BEING PUMPED AND GAS BALLAST IS USED THROTTLE THE COOLING WATER TO RAISE OPERATING TEMPERATURE TO THE LEVEL NEEDED FOR GAS BALLAST (SEE SECT. 3).**

## 2.6 LUBRICATION OF PUMP

The successful operation of this pump depends largely on the type of oil used. An initial charge of oil is included with each pump. This standard oil is V-Lube (Label F) which is recommended for general operating conditions in a relatively clean environment. The oil is a multigrade petroleum oil, fortified for oxidation protection, containing detergent dispersants, with excellent flow characteristics at low temperature. It has a viscosity of 430 SSU at 100 Deg. F., and 82 SSU at 210 Deg. F., with a vapor pressure of 0.0001 mm Hg. at 145 Deg. F.

If the pump is to be operated at vacuum levels that cause the oil temperature to exceed 160 Deg. F. for extended periods of time, a heavier grade oil should be used, Stokes V-lube (Label G) is available for oil temperatures up to 200 Deg. F.

Special operating conditions may require the use of Special oils. We have listed the most used special lubricants on the back page of the Bulletin enclosed, Greasing and Pumping Fluids for Vacuum Components. Consult Stokes for specific recommendations when other than regular petroleum oils are being used.

### 2.6.1 INITIAL FILL

The microvac pump is shipped with an Initial charge of oil (\* gallons) in the reservoir. Before connecting the suction manifold slowly rotate the pump thru two revolutions. This will distribute the oil throughout the pump interior.

|        |               |
|--------|---------------|
| 146-13 | 2 QUARTS      |
| 148-10 | 1-1/2 GALLONS |
| 149-11 | 2-1/2 GALLONS |
| 212-11 | 4 GALLONS     |
| 412-11 | 12 GALLONS    |

**NOTE:** STARTING THE MICROVAC PUMP WHEN OIL TEMPERATURE IS BELOW 55 DEG. F., CAN RESULT IN EXCESSIVE WEAR AND GALLING DAMAGE TO THE MOVING PARTS.

3.0 OPERATION

3.1 PRE-START CHECK

**NOTE:** REMOVE BELT GUARD COVER. TURN PUMP OVER BY HAND AT LEAST TWO REVOLUTIONS.

- A. Jog the motor momentarily while observing pump rotation. If the pump does not rotate in a clockwise direction, interchange any two of the three-phase leads.
- B. Make sure the oil solenoid valve operates properly by checking the oil flow indicator. The ball in the Oil Flow Indicator bowl should rise after system pressure is below 600 mm Hg. (6" Hg. Suction).
- C. The oil solenoid valve is normally closed, and must be energized when the pump starts.

The differential pressure between the oil reservoir (atmospheric pressure) and the pump cavity (vacuum) forces the oil to the bearings and into the pump cavity. The oil lubricates the moving parts and also creates an oil seal.

Oil starts to flow at 600 Torr. At 400 Torr the flow is approximately 50%. From 100% Torr to blank-off (15u), flow is 100%.

**NOTE:** YOU MUST REACH 400 TORR IN 10 MINUTES OR A FORCE FEED LUBRICATION SYSTEM IS REQUIRED TO PROVIDE ADEQUATE OIL FLOW TO THE PUMP CAVITY.

**NOTE:** IF INDICATOR BALL DOES NOT RISE, STOP PUMP IMMEDIATELY. (1) CHECK OPERATION OF SOLENOID. (2) CHECK OIL LINES FOR BLOCKAGE

3.1.2 DRIVE BELT TENSION

- A. At approximately the center of the span, between drive and driven pulleys, apply \* pounds pressure on the belt. If tension is correct, the resulting deflection should be \*\*.

| MODEL  | * LBS. | ** DEFLECTION |
|--------|--------|---------------|
| 146-13 | 1 TO 2 | 1/2"          |
| 148-10 | 3 TO 5 | 5/16 TO 3/8"  |
| 149-11 | 2 TO 3 | 7/16"         |
| 212-11 | 3 TO 5 | 7/16"         |
| 412-11 | 5 TO 7 | 1/2"          |

- B. Adjust, if necessary, by raising or lowering the location nuts on the motor support eyebolt. Tighten these nuts securely after adjustments.

**NOTE:** MAINTENANCE OF PROPER BELT TENSION IS IMPORTANT. TOO TIGHT ANY ADJUSTMENT IS HARMFUL TO THE SHAFT BEARINGS. TOO LOOSE AN ADJUSTMENT ALLOWS THE BELT TO SLIP.

### 3.2 PUMP START

3.2.1 for 149-11, 212-11 & 412-11 ONLY, Turn cooling water **ON**.

**CAUTION: DO NOT START PUMP WHEN OIL TEMPERATURE IS BELOW 55° F.**

**NOTE: REMOVE PLASTIC PLUG FROM EXHAUST PORT BEFORE OPERATING PUMP**

3.2.1 Depress "start" button and check solenoid valve for proper operation.

3.2.2 Be sure the equipment being evacuated is properly cleaned and all openings closed. Open intake valve.

### 3.3 CHECKING OIL LEVEL

3.3.1 Check oil level each day.

3.3.2 The oil level should be at center of sight glass or in lower half while pump is operating at high vacuum. Level will change depending on suction pressure. In most cases, oil is added after operating the pump for a short while.

3.3.3 To avoid blowing oil out the fill hole, do not add oil to the pump when in operation unless the pump is at 1 torr or less without Gas Ballast.

**NOTE:** When pumping gases that contain water vapor it may be necessary to remove the water that condenses in the pump reservoir sump. This can be done by opening the oil drain valve and draining out water, and closing valve when oil starts to flow. The interval for this must be determined for each specific operation and depends on the amount of water vapor and oil temperature. Operating the pump with the oil temperature in the 160 Deg. F., temperature range will tend to minimize formation of water, but will not eliminate it.

### 3.4 OPERATION OF GAS BALLAST

3.4.1 Open the Gas Ballast valve fully for maximum efficiency. For a lesser degree of ballasting, turn valve toward close position. Full gas ballast will cause pump temperature to rise but this is normal. For maximum effect of gas ballast, pump should be run approximately at 160 Deg. F.

*149-11, 212-11, & 412-11 ONLY* Operating temperature can be raised by throttling cooling water. Oil Temperature Control Kits are available, consult factory.

**NOTE:** Be sure to remove the plastic plug in the Gas Ballast air intake lines. This plug is used for shipping and storage purposes **ONLY**

3.4.2 If pumping water vapor in excessive quantities and the oil has become contaminated, it can be purified by running the pump with Gas Ballast valve full open while the pump is shut-off from the system. When excessive contaminants are present, indicated by high oil level, or thinning, formation of varnish, etc., the oil should be replaced.

**CAUTION:** Gas Ballast should never be used if vapors being pumped are explosive, e.g. Methane Gas, Hydrogen, and certain solvent vapors. When gases of an explosive nature are being handled, the safest procedure is to remove the gas ballast valve entirely and plug or cap the pipe to which the gas ballast valve is attached.

Opening the gas ballast slightly will quiet valve noise when pump is blanked-off, but will prevent reaching the lowest final pressure.

- 3.4.3 The check valve used for Gas Ballast should be inspected at least every six months for wear or a broken spring when operating on an (8) hour a day basis; every 3 months for (24) hour a day operation.

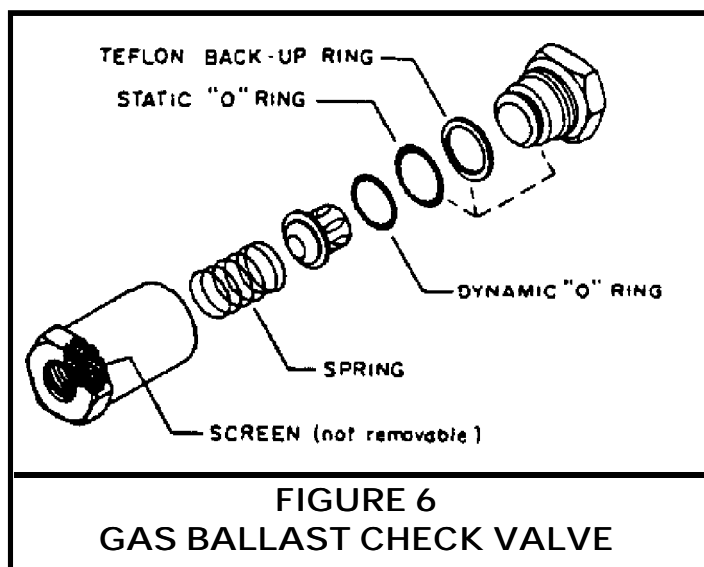

- 3.4.4 The gas ballast valve should be closed when the pump is stopped. If the valve is open, gas will be sucked into the pump through the valve and the vacuum manifold will be pressurized with atmospheric air. This air going through the pump will carry the oil in the pump cylinder system. A solenoid valve attached to the gas ballast piping can be used to operate the gas ballast automatically. Contact local Stokes representative for additional information.
- 3.4.5 When a pressurized gas is used to ballast the pump, the pressure must be reduced to 2 psi maximum. The use of higher pressures may damage the pump.
- 3.4.6 When pumping an explosive gas, (i.e. hydrogen, silane, methane) or corrosive gas, (cl, f, ccl4, etc.) the pump must be ballasted with an inert gas (nitrogen, argon). The used of air for ballasting under the above conditions can result in an explosion or excessive corrosion inside the pump.

### 3.5 PUMP STOP

- 3.5.1 Close intake valve to system.
- 3.5.2 Stop the motor and break vacuum unless system dictates otherwise.

**NOTE:** The solenoid valve closes automatically when the pump is stopped or in case of power failure, thus preventing pump and vacuum system from being flooded with oil.

### 3.6 OPERATING NOTES

3.6.1 If large amounts of air pass through the pump, it may become warm and under severe conditions may become hot. This does not indicate trouble. The pump is designated for high vacuum work and should not be operated at pressures above 600 mm Hg. for more than 15 minutes or at intermediate vacuums for periods which cause oil temperature to exceed 200 Deg. F. For optimum pump operation the oil temperature of the oil in the reservoir should be between 140 Deg. F. and 160 Deg. F. with the pump operating on the system or process. Oil temperature can be measured by inserting a thermometer in the fill hole or by contact pyrometer on oil line near the solenoid. If the pump is to be operated with oil temperature in excess of 160 Deg. F. the use of a heavier viscosity oil is recommended. (See Section 2.6.)

3.6.2 When starting the pump or when handling large amounts of air, oil vapor in the form of smoke will issue from the exhaust. Again this is no indication of trouble, as the volume of smoke will decrease as the vacuum in the system improves.

**NOTE:** Stokes closed type oil mist separator is available to alleviate exhaust oil smog.

3.6.3 If the pump has been shut down for an extended period, always turn over at least two (2) revolutions by hand before starting to insure free movement of parts.

3.6.4 Low oil temperature can cause overloading when starting the pump and possibly prevent the pump from sealing. Microvac pumps should not be started when the oil temperature is below 55 Deg. F.\* Optimum operating oil temperature after starting is between 140 Deg. F. to 160 Deg. F. Opening the Gas Ballast valve will help warm-up the oil.

A Water Miser is recommended to automatically control the oil temperature.

\*THIS APPLIES ONLY IF STOKES V-LUBE "F" IS USED. CONSULT FACTORY IF OTHER OILS ARE USED.

## 4.0 CHECKING

### 4.1 POOR VACUUM

No pump will give good results on a poor vacuum system. If the vacuum in the system is unsatisfactory, the usual cause is leakage. To check for this condition, a methodical approach will usually resolve the problem in the least amount of time.

### 4.2 LOCALIZING LEAKAGE

A leak rate will help localize a vacuum leak. Such a test is easily made by successively isolating and evacuating each section of the system. The in-leakage rate of the isolated section is then noted.

4.2.1 A vacuum leak detector will speed up the process of the locating leaks.

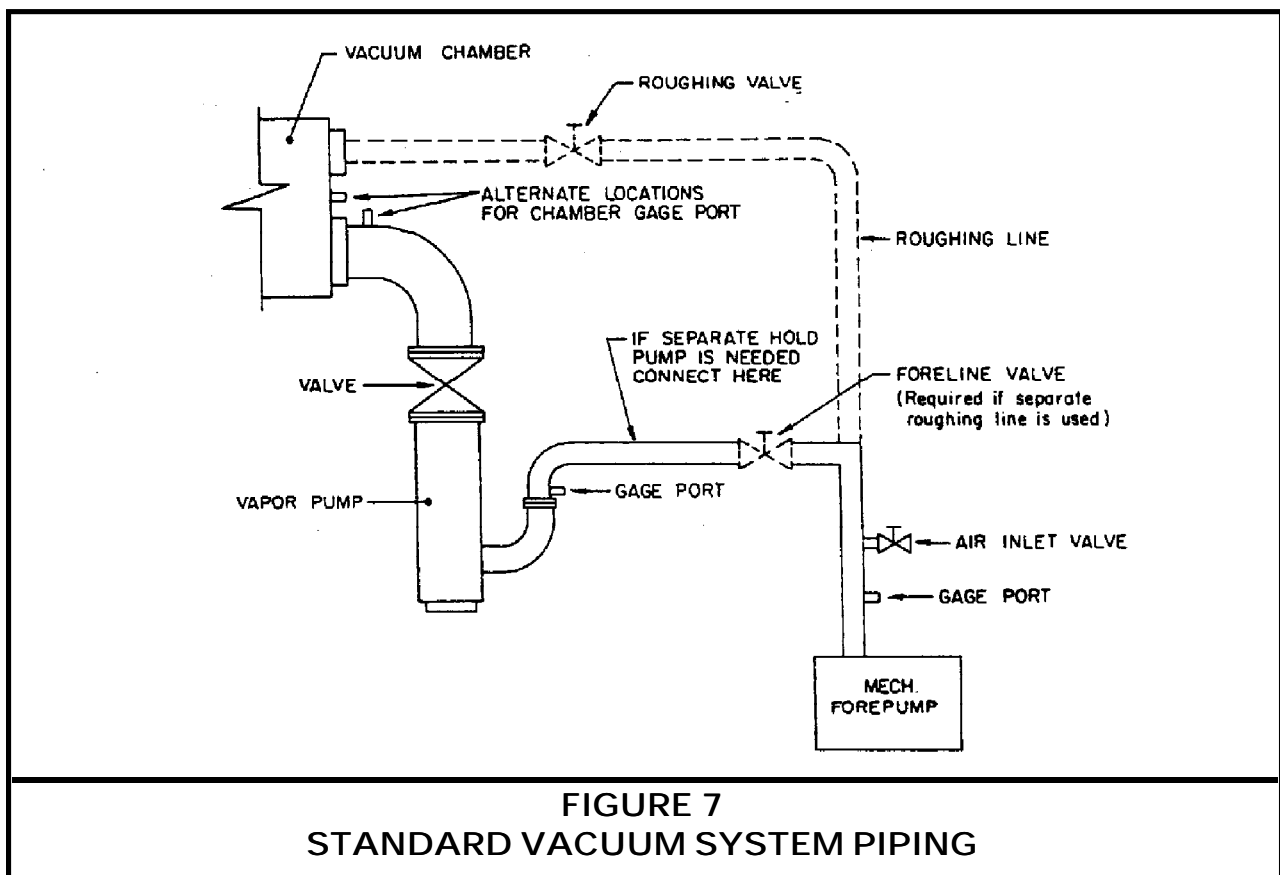

### 4.3 REPAIRING SMALL LEAKS

To repair small leaks or to close pores, use Sealing Compound, Stokes Part No. 4-927. When replacing plug type valves (if used) use Loctite Pipe Sealer No. 714-I to help seal them. Gate, Ball or Butterfly type high vacuum valves are preferred for high vacuum service.

**NOTE:** Use of Teflon Tape for sealing is not recommended. Material is often drawn into system, causing premature wear and damage to moving parts.



4.4 PUMP ACTIVITY RECORD

A record of oil changes, work done on pump, and changes or additions to the system will be of value in checking for leaks or poor vacuum.

**NOTE:** A sample mechanical vacuum pump preventive maintenance check list along with a summary of major attention items is enclosed for your review.

5.0 TROUBLESHOOTING GUIDE

| <b>VACUUM AT PUMP IS UNSATISFACTORY</b>                                     |  |
|---|--|
| <i>PROBABLE CAUSE</i>   | <i>POSSIBLE REMEDY</i>   |
| A. CONTAMINATED OR INSUFFICIENT OIL.  | <ol style="list-style-type: none"> <li>1. CHECK OIL LEVEL; UTILIZE GAS BALLAST.</li> <li>2. DRAIN AND WIPE OUT RESERVOIR AND VALVE CHAMBER. REFILL WITH PROPER OIL.</li> </ol>   |
| B. SOLENOID OIL VALVE NOT OPERATING PROPERLY OR INOPERATIVE.                | CHECK AND, IF NECESSARY CLEAN AND OR REPLACE SOLENOID VALVE OR COIL.   |
| C. LOOSE INTAKE FLANGE OR COVER BOLTS.                                      | TIGHTEN FALNGE AND SIDE COVER BOLTS AT REGULAR INTERVALS.  |
| D. OIL MANIFOLD OR INTERGRAL OIL DISTRIBUTION LEAKING.                      | TIGHTEN PLUGS AND MANIFOLD SCREWS.   |
| E. OIL LEVEL SIGHT GLASS LEAKING  | CAREFULLY TIGHTEN SCREWS   |
| F. EXHAUST VALVE NOT SEALING  | <ol style="list-style-type: none"> <li>1. DISASSEMBLE, CLEAN AND CHECK ALL PARTS THOROUGHLY.</li> <li>2. REPLACE ANY DAMAGED OR WORN PARTS.</li> </ol>   |
| G. PUMP SEIZES OR KNOCKS EXCESSIVELY; INTERNAL PARTS BADLY WORN OR BROKEN   | DISASSEMBLE PISTON ASSEMBLY. REPLACE WORN, BROKEN OR BADLY SCORED PARTS.   |
| H. LEAKAGE IN VACUUM SYSTEM   | CHECK SYSTEM AS DESCRIBED IN SECTION 4.0.  |
| <b>VACUUM PUMP EXCESSIVELY NOISY</b>  |  |
| <i>PROBABLE CAUSE</i>   | <i>POSSIBLE REMEDY</i>   |
| A. PUMP KNOCKING  | <ol style="list-style-type: none"> <li>1. CHECK OIL LEVEL, AND OIL SOLENOID VALVE FOR PROPER OPERATION.</li> <li>2. BROKEN PARTS OR FOREIGN MATERIAL IN THE PUMP.</li> <li>3. DISASSEMBLE AND REMOVE FOREIGN MATERIAL IN THE PUMP.</li> <li>4. REPLACE BROKEN PARTS AS REQUIRED.</li> </ol>  |
| B. PUMP SEIZES DUE TO LACK OF LUBRICATION, OR PRESENCE OF FOREIGN MATERIAL. | <ol style="list-style-type: none"> <li>1. CHECK SOLENOID VALVE FOR PROPER OPERATION.</li> <li>2. DISASSEMBLE AND REMOVE FOREIGN MATERIAL. MAKE SURE OIL LINES ARE NOT CLOGGED.</li> <li>3. SMOOTH MINOR SCORING WITH #500 EMERY CLOTH AND WASH THOROUGHLY THEN OIL BEFORE INSTALLING. (A CERTAIN AMOUNT OF SCORING TO THE PISTON AND CYLINDER AND OTHER PARTS USUALLY WILL NOT SERIOUSLY AFFECT THE VACUUM OBTAINABLE SO LONG AS SCORING IS NOT IN A CONTINUOUS GOUGE AROUND THE CIRCUMFRENCE OF THE PISTON SURFACE.)</li> </ol> |

|   |  |
|---|--|
| <b>MOTOR STOPS OR WILL NOT START</b>  |  |
| <i>PROBABLE CAUSE</i>   | <i>POSSIBLE REMEDY</i>   |
| A. THERMAL OVERLOAD UNITS IN MOTOR STARTER FAIL.  | CHECK CAPACITY OF THERMAL OVERLOAD UNITS BY COMPARING AMPERE RATING ON MOTOR NAMEPLATE WITH OVERLOAD TABLE INSIDE STARTER BOX. IF NECESSARY USE 1 SIZE LARGER THAN STANDARD.   |
| B. POSSIBLE INTERNAL SEIZURE.   | DISASSEMBLE AND CORRECT.   |
| <b>PUMP DOES NOT TURN WHEN MOTOR STARTS</b>   |  |
| <i>PROBABLE CAUSE</i>   | <i>POSSIBLE REMEDY</i>   |
| A. V-BELTS TOO LOOSE.   | TIGHTEN V-BELTS. SEE SECTION 3.1.2 PARAGRAPH B.  |
| B. CYLINDER MAY BE FLOODED WITH EXCESSIVE OIL DUE TO DEFECTIVE SOLENOID VALVE. (THE VALVE MAY HAVE STUCK IN THE OPEN POSITION AT THE MOMENT OF PREVIOUS SHUT DOWN, OR FOREIGN MATERIAL MAY BE IN VALVE SEAT.) | TURN PUMP OVER BY HAND TO REMOVE EXCESS OIL. DISASSEMBLE VALVE, CLEAN AND REPLACE ANY WORN PARTS. CHECK SOLENOID.  |
| C. OIL VISCOSITY IS TOO HIGH OR OIL TEMPERATURE MAY BE TOO LOW.   | <ol style="list-style-type: none"> <li>1. CHANGE TO LIGHTER GRADE OIL, OR WARM OIL BEFORE POURING INTO PUMP (ESPECIALLY WITH LOW AMBIENT TEMPERATURES.) PUMP SHOULD NOT BE STARTED WHEN OIL TEMPERATURE IS LESS THAN 70 DEGREES F. (WHEN USING V-LUBE "F".)</li> <li>2. TURN PUMP OVER BY HAND BEFORE STARTING.</li> </ol> |
| <b>PUMP TURNS BACKWARDS FOR SEVERAL REVOLUTIONS WHEN MOTOR IS TURNED OFF.</b>   |  |
| <i>PROBABLE CAUSE</i>   | <i>POSSIBLE REMEDY</i>   |
| A. GAS BALLAST VALVE IN OPEN POSITION WHEN PUMP WAS SHUT DOWN.  | CLOSE GAS BALLAST VALVE BEFORE SHUTTING OFF PUMP. THIS PREVENTS ATMOSPHERIC AIR FROM REVERSING DIRECTION OF PUMP PISTON WHEN PUMP IS SHUTDOWN. THIS PROCEDURE ALSO PREVENTS OIL FROM BEING PUSHED INTO THE INLET PIPING.   |

# SPECIFICATIONS AND PERFORMANCE CURVES

## MODEL 146H-13

|                               |                                  |
|-------------------------------|----------------------------------|
| <b>ULTIMATE VACUUM</b>        | 10 MICRONS HG. OR LESS           |
| <b>DISPLACEMENT - CU. FT.</b> | 30 CFM                           |
| <b>PUMP SPEED</b>             | 800 RPM                          |
| <b>MOTOR</b>                  | 1.5 HP                           |
| <b>MOTOR SPEED</b>            | 1800 RPM SYNC.                   |
| <b>STD. ELECTRICAL SPECS.</b> | 3/60/230/460                     |
| <b>PIPE CONNECTIONS</b>       |                                  |
| <b>SUCTION</b>                | 2" STD. FLG.                     |
| <b>DISCHARGE</b>              | 1-1/4" NPT                       |
| <b>OIL CAPACITY</b>           | 1/2 GAL. (2 LITERS)              |
| <b>NET WEIGHT</b>             | 315 LBS. (143 KG.)               |
| <b>SHIPPING WEIGHT</b>        | 390 LBS. (177 KG.)               |
| <b>HEIGHT</b>                 | 30" (762 MM)                     |
| <b>FLOOR SPACE</b>            | 15-1/2" X 16-3/4" (394 X 425 MM) |
| <b>COOLING</b>                | AIR COOLED                       |

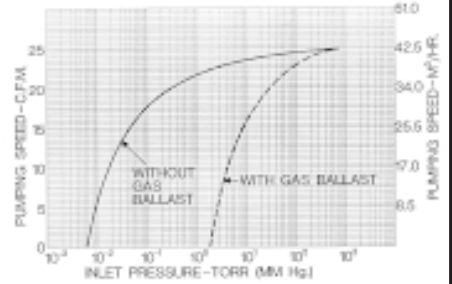

## MODEL 148H-10

|                               |                                  |
|-------------------------------|----------------------------------|
| <b>ULTIMATE VACUUM</b>        | 10 MICRONS HG. OR LESS           |
| <b>DISPLACEMENT - CU. FT.</b> | 50 CFM                           |
| <b>PUMP SPEED</b>             | 610 RPM                          |
| <b>MOTOR</b>                  | 2 HP                             |
| <b>MOTOR SPEED</b>            | 1800 RPM SYNC.                   |
| <b>STD. ELECTRICAL SPECS.</b> | 3/60/230/460                     |
| <b>PIPE CONNECTIONS</b>       |                                  |
| <b>SUCTION</b>                | 1-1/2" STD. FLG.                 |
| <b>DISCHARGE</b>              | 1-1/2" NPT                       |
| <b>OIL CAPACITY</b>           | 1-1/4 GAL. (5 LITERS)            |
| <b>NET WEIGHT</b>             | 345 LBS. (157 KG.)               |
| <b>SHIPPING WEIGHT</b>        | 435 LBS. (197 KG.)               |
| <b>HEIGHT</b>                 | 32" (813 MM)                     |
| <b>FLOOR SPACE</b>            | 27-1/4" X 18-7/8" (421 X 486 MM) |
| <b>COOLING</b>                | AIR COOLED                       |

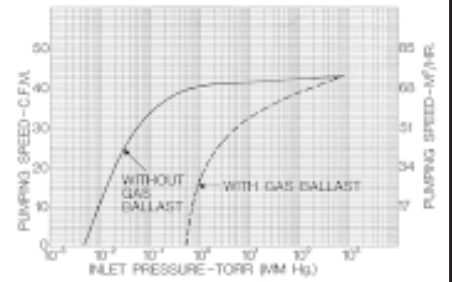

## MODEL 149H-11

|                               |                                  |
|-------------------------------|----------------------------------|
| <b>ULTIMATE VACUUM</b>        | 10 MICRONS HG. OR LESS           |
| <b>DISPLACEMENT - CU. FT.</b> | 80 CFM                           |
| <b>PUMP SPEED</b>             | 490 RPM                          |
| <b>MOTOR</b>                  | 3 HP                             |
| <b>MOTOR SPEED</b>            | 1800 RPM SYNC.                   |
| <b>STD. ELECTRICAL SPECS.</b> | 3/60/230/460                     |
| <b>PIPE CONNECTIONS</b>       |                                  |
| <b>SUCTION</b>                | 2" STD. FLG.                     |
| <b>DISCHARGE</b>              | 1-1/2" NPT                       |
| <b>WATER INLET</b>            | 1/2" NPT                         |
| <b>WATER OUTLET</b>           | 1/2" NPT                         |
| <b>OIL CAPACITY</b>           | 2-1/2 GAL. (10 LITERS)           |
| <b>NET WEIGHT</b>             | 565 LBS. (256 KG.)               |
| <b>SHIPPING WEIGHT</b>        | 675 LBS. (306 KG.)               |
| <b>HEIGHT</b>                 | 38-7/8" (987 MM)                 |
| <b>FLOOR SPACE</b>            | 23-1/2" X 20-1/8" (597 X 511 MM) |
| <b>COOLING</b>                | WATER                            |

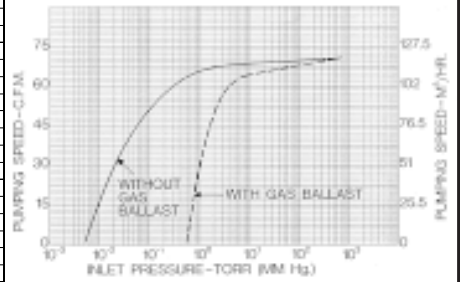

## MODEL 212H-11

|                               |                              |
|-------------------------------|------------------------------|
| <b>ULTIMATE VACUUM</b>        | 10 MICRONS HG. OR LESS       |
| <b>DISPLACEMENT - CU. FT.</b> | 150 CFM                      |
| <b>PUMP SPEED</b>             | 500 RPM                      |
| <b>MOTOR</b>                  | 7-1/2 HP                     |
| <b>MOTOR SPEED</b>            | 1800 RPM SYNC.               |
| <b>STD. ELECTRICAL SPECS.</b> | 3/60/230/460                 |
| <b>PIPE CONNECTIONS</b>       |                              |
| <b>SUCTION</b>                | 3" FLANGED                   |
| <b>DISCHARGE</b>              | 2" SCREWED                   |
| <b>WATER INLET</b>            | 1/2" NPT                     |
| <b>WATER OUTLET</b>           | 1/2" NPT                     |
| <b>OIL CAPACITY</b>           | 4 GAL. (15 LITERS)           |
| <b>NET WEIGHT</b>             | 950 LBS. (431 KG.)           |
| <b>SHIPPING WEIGHT</b>        | 1075 LBS. (488 KG.)          |
| <b>HEIGHT</b>                 | 43-1/2" (1105 MM)            |
| <b>FLOOR SPACE</b>            | 26-1/4" X 24" (667 X 610 MM) |
| <b>COOLING</b>                | WATER                        |

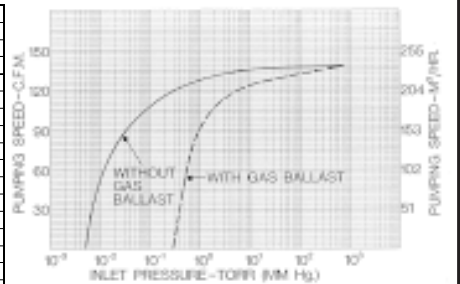

## MODEL 412H-11

|                               |                                   |
|-------------------------------|-----------------------------------|
| <b>ULTIMATE VACUUM</b>        | 10 MICRONS HG. OR LESS            |
| <b>DISPLACEMENT - CU. FT.</b> | 300 CFM                           |
| <b>PUMP SPEED</b>             | 490 RPM                           |
| <b>MOTOR</b>                  | 10 HP                             |
| <b>MOTOR SPEED</b>            | 1800 RPM SYNC.                    |
| <b>STD. ELECTRICAL SPECS.</b> | 3/60/230/460                      |
| <b>PIPE CONNECTIONS</b>       |                                   |
| <b>SUCTION</b>                | 4" FLANGED                        |
| <b>DISCHARGE</b>              | 3" SCREWED                        |
| <b>WATER INLET</b>            | 1/2" NPT                          |
| <b>WATER OUTLET</b>           | 1/2" NPT                          |
| <b>OIL CAPACITY</b>           | 12 GAL. (46 LITERS)               |
| <b>NET WEIGHT</b>             | 1750 LBS. (794 KG.)               |
| <b>SHIPPING WEIGHT</b>        | 1975 LBS. (896 KG.)               |
| <b>HEIGHT</b>                 | 51-3/4" (1314 MM)                 |
| <b>FLOOR SPACE</b>            | 40-1/4" X 25-5/8" (1022 X 651 MM) |
| <b>COOLING</b>                | WATER                             |

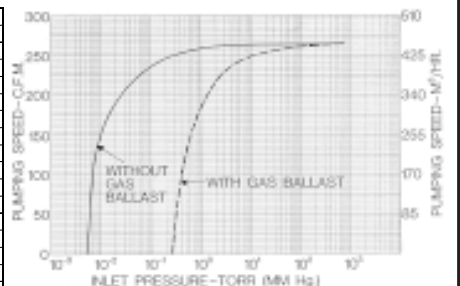

**SECTION 6.0**

**SPECIFICATIONS**

**AND PARTS LISTS**

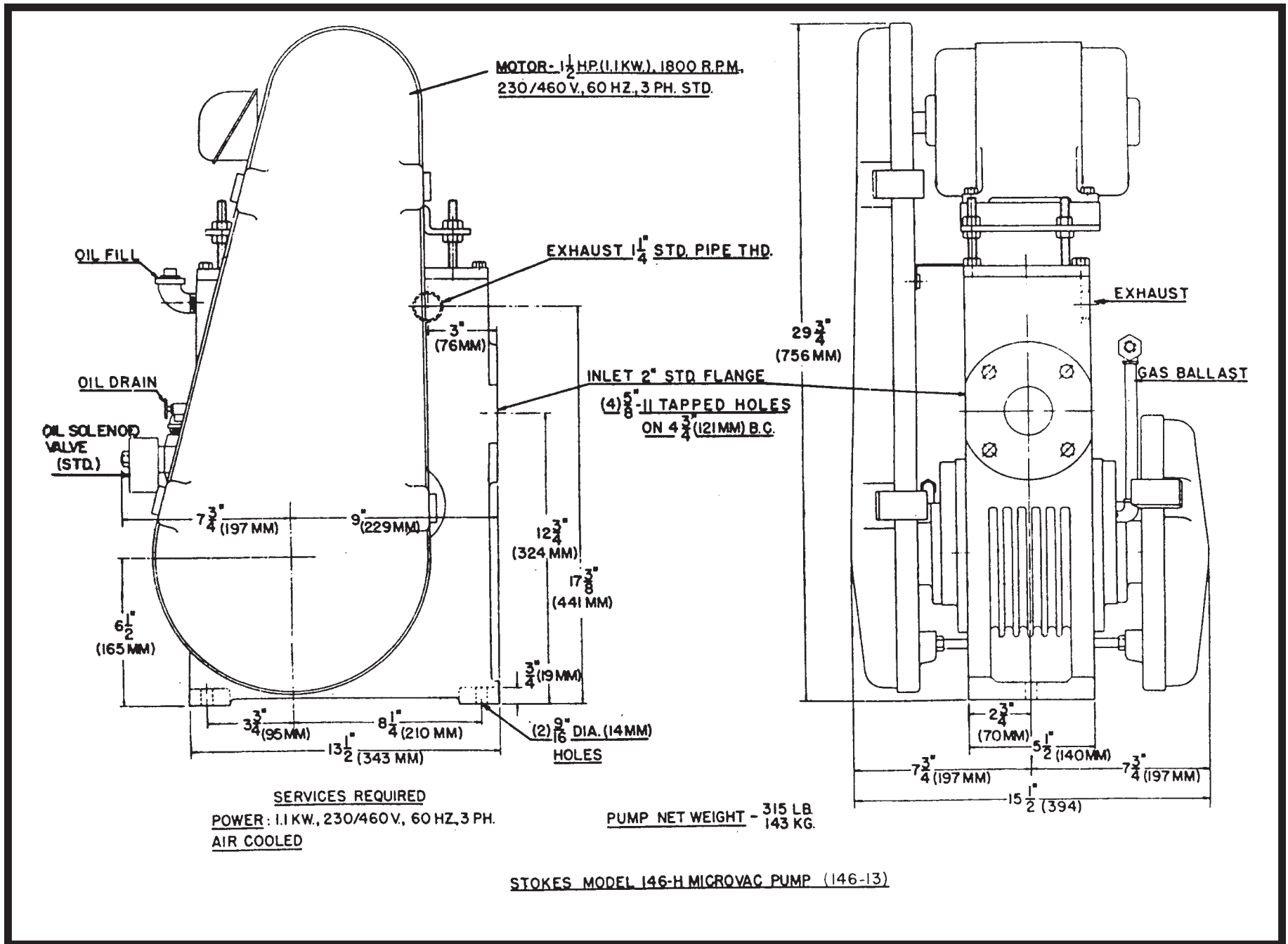

# MODEL 146-H13 MICROVAC PUMP

## LOT NO. SCC-79852 TO

| SYM | PART NO.    | DESCRIPTION                      | REF. DWG/<br>COMP. LIT. | QTY | UM | RSP |
|-----|-------------|----------------------------------|-------------------------|-----|----|-----|
| 1   | F-267-302-5 | Pump Housing                     | F-267-302-5             | 1   | EA |     |
| 2   | C-419-148-2 | Side Cover, Drive End            | C-419-148-2             | 1   | EA |     |
| 3   | C-419-148-1 | Side Cover, Dead End             | C-419-148-1             | 1   | EA |     |
| 4   | C-267-317-2 | Pulley                           | C-267-317-2             | 1   | EA |     |
| 5   | B-267-316-5 | End Cap Drive End                | B-267-316-5             | 1   | EA |     |
| 6   | C-267-317-1 | Flywheel                         | C-267-317-1             | 1   | EA |     |
| 7   | B-267-316-5 | End Cap, Dead End                | B-267-316-5             | 1   | EA |     |
| 8   | 085-036-951 | Oil Seal                         |                         | 2   | EA | ✓   |
| 9   | 085-019-689 | "O" Ring, End Cap                |                         | 2   | EA | ✓   |
| 10  | A-267-330-1 | Bearing Shim                     | A-267-330-1             | 1   | EA |     |
| 11  | 085-035-805 | Retaining Ring                   |                         | 1   | EA |     |
| 12  | 085-019-684 | Ball Bearing                     |                         | 2   | EA |     |
| 13  | A-408-885-3 | Shaft Ring, Drive End            | A-408-885-3             | 1   | EA |     |
| 14  | A-408-885-1 | Shaft Ring, Dead End             | A-408-885-1             | 1   | EA |     |
| 15  | 085-036-139 | Split Collar                     |                         | 1   | EA |     |
| 16  | C-267-305-3 | Piston & Slide                   | C-267-305-3             | 1   | EA |     |
| 17  | C-267-314-8 | Hinge Bars                       | C-267-314-8             | 2   | EA |     |
| 18  | C-268-362-3 | Eccentric                        | C-268-362-3             | 1   | EA |     |
| 19  | A-264-523-1 | Woodruff Key                     | A-264-523-1             | 1   | EA |     |
| 20  | A-270-891-1 | Woodruff Key                     | A-270-891-1             | 2   | EA |     |
| 21  | C-267-318-7 | Shaft                            | C-267-318-7             | 1   | EA |     |
| 22  | C-267-312-5 | Motor Mounting Plate             | C-267-312-5             | 1   | EA |     |
| 23  | C-267-306-5 | Top Cover Plate                  | C-267-306-5             | 1   | EA |     |
| 24  | B-273-888-1 | Top Cover Plate Gasket           | B-273-888-1             | 1   | EA | ✓   |
| 25  | A-421-243-1 | Oil Separator Enclosure          | A-421-243-1             | 1   | EA |     |
| 26  | B-421-760-1 | Exhaust Unit                     | B-421-760-1             | 1   | EA |     |
| 27  | B-267-319-3 | Valve Deck Assembly Consists Of: | B-267-319-3             | 1   | EA |     |
| 27A | B-287-344-1 | Valve Cap                        | B-287-344-1             | 1   | EA |     |
| 27B | A-274-172-1 | Valve Spring                     | A-274-172-1             | 1   | EA | ✓   |
| 27C | A-272-963-2 | Valve Clapper                    | A-272-963-2             | 1   | EA | ✓   |
| 27D | B-287-345-1 | Valve Seat                       | B-287-345-1             | 1   | EA |     |
| 27E | 085-020-752 | Cap Screw W/Nylon Insert         |                         | 4   | EA | ✓   |
| 31  | A-267-329-2 | Valve Plate Gasket               | A-267-329-2             | 1   | EA | ✓   |

RSP = RECOMMENDED SPARE PART  
UM = UNIT OF MEASURE

# MODEL 146-H13 MICROVAC PUMP

## LOT NO. SCC-79852 TO

| SYM | PART NO.    | DESCRIPTION   | REF. DWG/<br>COMP. LIT. | QTY | UM | RSP |
|-----|-------------|---|-------------------------|-----|----|-----|
| 32  | A-420-103-1 | Oil Separator Gasket                                  | A-420-103-1             | 1   | EA | ✓   |
| 33  | 085-030-713 | Solenoid Valve  |                         | 1   | EA | ✓   |
|     | 085-030-950 | Solenoid Valve Coil, 240/480V., 60 HZ                 |                         | 1   | EA | ✓   |
| 34  | A-417-251-2 | Oil Flow Indicator Assembly Consists of the following | A-417-251-2             | 1   | EA | ✓   |
|     | 085-029-269 | Oil Flow Indicator Body                               |                         | 1   | EA |     |
|     | 085-034-799 | Glass Dome (Oil Flow Ind.)                            |                         | 1   | EA |     |
|     | 085-038-817 | Gasket, Buna-N (1/32" Thk Oil Flow Indicator)         |                         | 1   | EA | ✓   |
|     | 085-038-818 | Gasket, Viton (1/16" Thk Oil Flow Indicator)          |                         | 1   | EA | ✓   |
| 35  | A-403-987-1 | Oil Line Tube   | A-403-987-1             | 2   | EA |     |
| 36  | 085-013-211 | Drain Cock  |                         | 1   | EA |     |
| 37  | 052-001-014 | Oil Level Sight Glass                                 |                         | 1   | EA |     |
| 38  | A-520-708-1 | Spacers (Belt and Flywheel Guards                     | A-520-708-1             | 3   | EA |     |
| 39  | D-411-671-2 | Belt Guard Assembly                                   | D-411-671-2             | 1   | EA |     |
| 40  | B-411-668-1 | Belt Guard Bracket                                    | B-411-668-1             | 1   | EA |     |
| 41  | D-408-301-4 | Flywheel Guard Assembly                               | D-408-301-4             | 1   | EA |     |
| 42  | 085-021-964 | Check Valve (Viton)                                   |                         | 1   | EA |     |
|     | 085-024-131 | Check Valve, "O" Ring (Dynamic)                       |                         | 1   | EA | ✓   |
|     | 085-024-132 | Check Valve, "O" Ring (Static)                        |                         | 1   | EA | ✓   |
|     | 085-024-133 | Check Valve, Back Up Ring, Teflon                     |                         | 1   | EA |     |
|     | 085-024-134 | Check Valve Spring                                    |                         | 1   | EA | ✓   |
| 43  | 085-021-810 | Ball Valve, 1/4" NPT                                  |                         | 1   | EA |     |
| 44  | 085-037-452 | Thrust Washer   |                         | 1   | EA | ✓   |
|     | 254-117-002 | Stokes, V-Lube, 1 Gal. Can, Label "F"                 |                         | 1   | EA | ✓   |
|     | 085-030-022 | Pulley, 4.5" P.D. X 7/8" Bore                         |                         | 1   | EA |     |
|     | 012-001-007 | "V" Belt, 61.3 P.L.                                   |                         | 1   | EA | ✓   |
|     |             |   |                         |     |    |     |
|     |             |   |                         |     |    |     |
|     |             |   |                         |     |    |     |
|     |             |   |                         |     |    |     |
|     |             |   |                         |     |    |     |
|     |             |   |                         |     |    |     |
|     |             |   |                         |     |    |     |
|     |             |   |                         |     |    |     |
|     |             |   |                         |     |    |     |

RSP = RECOMMENDED SPARE PART  
UM = UNIT OF MEASURE



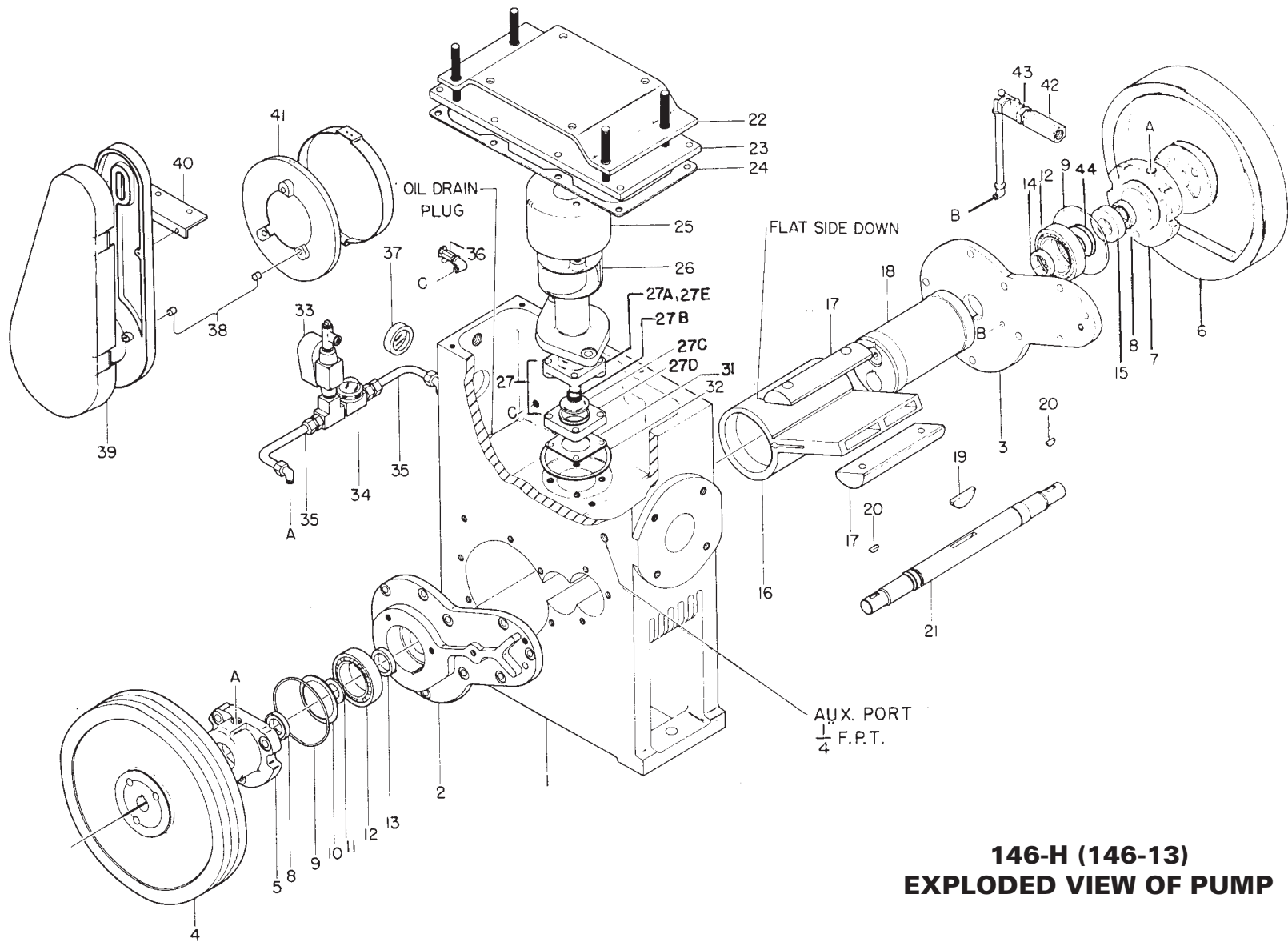

**146-H (146-13)  
EXPLODED VIEW OF PUMP**

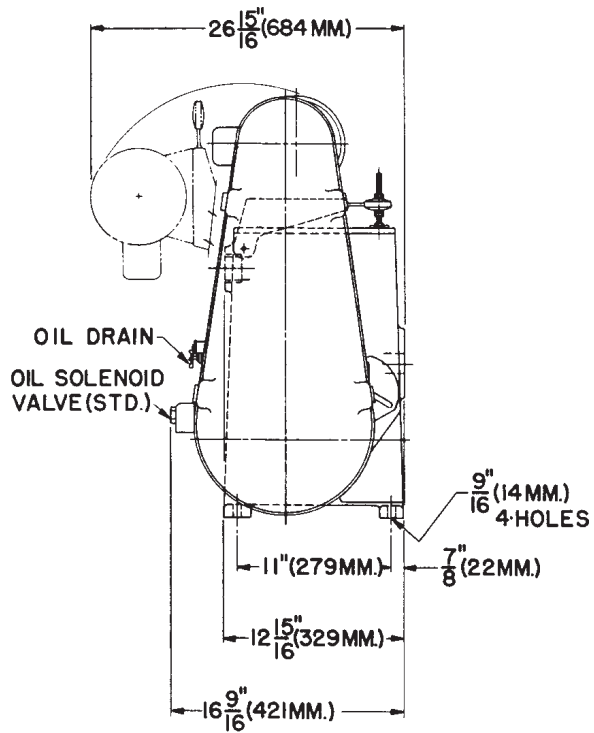

**SERVICES REQUIRED:-**  
 POWER - 2 HP, 230/460 V, 60 HZ., 3 PH.  
 AIR COOLED.

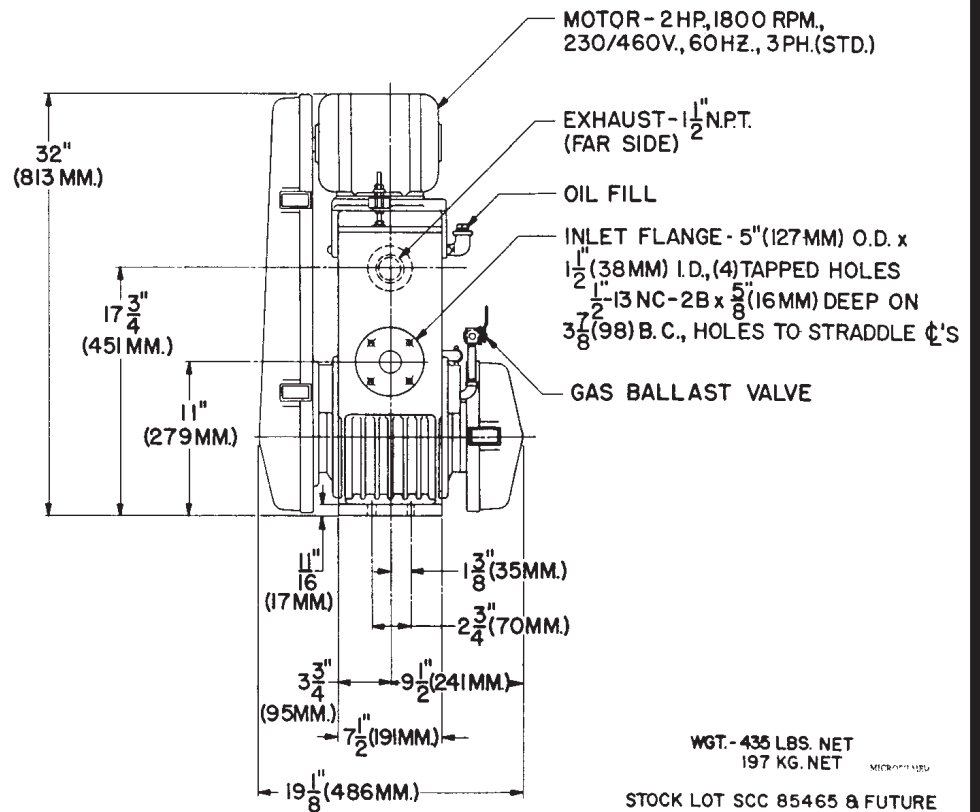

WGT. - 435 LBS. NET  
 197 KG. NET

STOCK LOT SCC 85465 & FUTURE

**STOKES®**  
**VACUUM**

STOKES MODEL 148-H MICROVAC PUMP

DWG. NO. - D - 258-401-12

# MODEL 148-H10 MICROVAC PUMP

## LOT NO. SCC-79919 FUTURE

| SYM | PART NO.     | DESCRIPTION                                 | REF. DWG/<br>COMP. LIT. | QTY | UM | RSP |
|-----|--------------|---|-------------------------|-----|----|-----|
| 1   | F-254-593-14 | Pump Housing                                |                         | 1   | EA |     |
| 2   | C-254-686-14 | Flywheel W/Taper Lock Bushing (085-030-300) |                         | 1   | EA |     |
| 3   | A-406-196-4  | Oil Line                                    |                         | 1   | EA |     |
| 3A  | A-406-196-5  | Oil Line                                    |                         | 1   | EA |     |
| 5   | 085-030-713  | Solenoid Valve, 240/480V                    |                         | 1   | EA | ✓   |
| 5A  | 085-030-950  | Solenoid Valve Coil, 240/480V.              |                         | 1   | EA | ✓   |
| 5B  | 085-030-958  | Solenoid Valve Coil, 550V.                  |                         | 1   | EA | ✓   |
| 6   | C-254-687-6  | End Cap, Dead End                           |                         | 1   | EA |     |
| 7   | 085-005-131  | "O" Ring, 3-1/4" ID X 3-1/2" OD x .139 Thk. |                         | 2   | EA | ✓   |
| 8   | 085-018-194  | Rotary Oil Seal (Viton)                     |                         | 2   | EA | ✓   |
| 9   | A-262-172-1  | Shaft Seal Ring                             |                         | 2   | EA |     |
| 10  | 085-016-212  | Bearing Adapter                             |                         | 2   | EA |     |
| 11  | 018-005-030  | Bearing Adapter Lockwasher                  |                         | 2   | EA | ✓   |
| 12  | 085-016-211  | Spherical Roller Bearing                    |                         | 2   | EA | ✓   |
| 13  | A-265-924-1  | Shaft Shoulder Ring                         |                         | 2   | EA |     |
| 14  | D-254-624-7  | Side Cover, Dead End                        |                         | 1   | EA |     |
| 15  | C-254-612-5  | Eccentric                                   |                         | 1   | EA |     |
| 16  | B-254-688-7  | Hinge Bar                                   |                         | 2   | EA |     |
| 17  | C-254-609-1  | Piston & Slide                              |                         | 1   | EA |     |
| 18  | C-254-617-5  | Shaft                                       |                         | 1   | EA |     |
| 19  | A-264-521-1  | Woodruff Key                                |                         | 4   | EA | ✓   |
| 20  | C-254-687-6  | End Cap, Drive End                          |                         | 1   | EA |     |
| 21  | D-254-624-8  | Side Cover, Drive End                       |                         | 1   | EA |     |
| 22  | C-254-686-13 | Pulley W/Taper Lock Bushing (085-030-300)   |                         | 1   | EA |     |
|     | A-408-300-4  | Stand Off                                   |                         | 6   | EA |     |
|     | D-411-096-3  | Belt Guard Bracket                          |                         | 1   | EA |     |
| 25  | A-254-759-3  | Motor Stud 3/8"- 16" X 5 3/8" Lg.           |                         | 1   | EA |     |
| 26  | C-286-115-4  | Motor Platform                              |                         | 1   | EA |     |
| 28  | A-275-235-6  | Motor Bracket Pin                           |                         | 2   | EA |     |
| 29  | B-415-363-5  | Reservoir Cover                             |                         | 1   | EA |     |
| 30  | C-257-663-2  | Reservoir Cover Gasket                      |                         | 1   | EA | ✓   |
| 31  | C-254-638-3  | Oil Baffle                                  |                         | 1   | EA |     |

RSP = RECOMMENDED SPARE PART  
UM = UNIT OF MEASURE

# MODEL 148-H10 MICROVAC PUMP LOT NO. SCC-79919 FUTURE

| SYM | PART NO.    | DESCRIPTION   | REF. DWG/<br>COMP. LIT. | QTY | UM | RSP |
|-----|-------------|---|-------------------------|-----|----|-----|
| 32  | B-257-654-1 | Oil Baffle Gasket                                   |                         | 1   | EA | ✓   |
| 33  | B-263-840-4 | Valve Assembly Consists Of:                         |                         | 1   | EA |     |
| 33A | B-403-626-3 | Valve Cap   |                         | 1   | EA |     |
| 33B | A-274-172-1 | Valve Spring  |                         | 2   | EA | ✓   |
| 33C | A-272-963-2 | Valve Clapper 304 SS                                |                         | 2   | EA | ✓   |
| 33D | B-403-636-2 | Valve Seat  |                         | 1   | EA |     |
| 34  | A-243-926-2 | Valve Plate Gasket                                  |                         | 1   | EA | ✓   |
| 35  | 085-036-101 | Oil Level Indicator                                 |                         | 1   | EA |     |
| 36  | 085-033-233 | Brass Cock, 1/2" MPT                                |                         | 1   | EA |     |
| 37  | 085-021-810 | Ball Valve, 1/4" IPS                                |                         | 1   | EA |     |
| 38  | 085-021-964 | Check Valve, 1/4" IPS                               |                         | 1   | EA |     |
|     | 085-024-134 | Check Valve Spring                                  |                         | 1   | EA | ✓   |
|     | 085-024-131 | Check Valve "O" Ring (Dynamic)                      |                         | 1   | EA | ✓   |
|     | 085-024-132 | Check Valve, "O" Ring (Static)                      |                         | 1   | EA | ✓   |
|     | 085-024-133 | Check Valve Back-Up Ring                            |                         | 1   | EA | ✓   |
|     | 085-017-571 | Motor Pulley, 1 Groove                              |                         | 1   | EA |     |
|     | 085-015-088 | "V" Belts   |                         | 1   | EA | ✓   |
|     | 254-117-002 | Stokes V-Lube Pump Oil, 1 Gal. Can (Label F)        |                         | 1   | EA | ✓   |
|     | A-417-251-2 | Oil Flow Indicator Ass'y Consists of the following: |                         | 1   | EA |     |
|     | 085-029-269 | Oil Flow Indicator Body                             |                         | 1   | EA |     |
|     | 085-034-799 | Glass Dome (Oil Flow Ind.)                          |                         | 1   | EA |     |
|     | 085-038-817 | Gasket, Buna-N (1/32" Thk Oil Flow Indicator)       |                         | 1   | EA | ✓   |
|     | 085-038-818 | Gasket, Viton (1/16" Thk Oil Flow Indicator)        |                         | 1   | EA | ✓   |
|     | D-411-062-3 | Flywheel Guard Ass'y                                |                         | 1   | EA |     |
|     | D-411-653-2 | Belt Guard Assembly                                 |                         | 1   | EA |     |
|     |             |   |                         |     |    |     |
|     |             |   |                         |     |    |     |
|     |             |   |                         |     |    |     |

RSP = RECOMMENDED SPARE PART  
UM = UNIT OF MEASURE

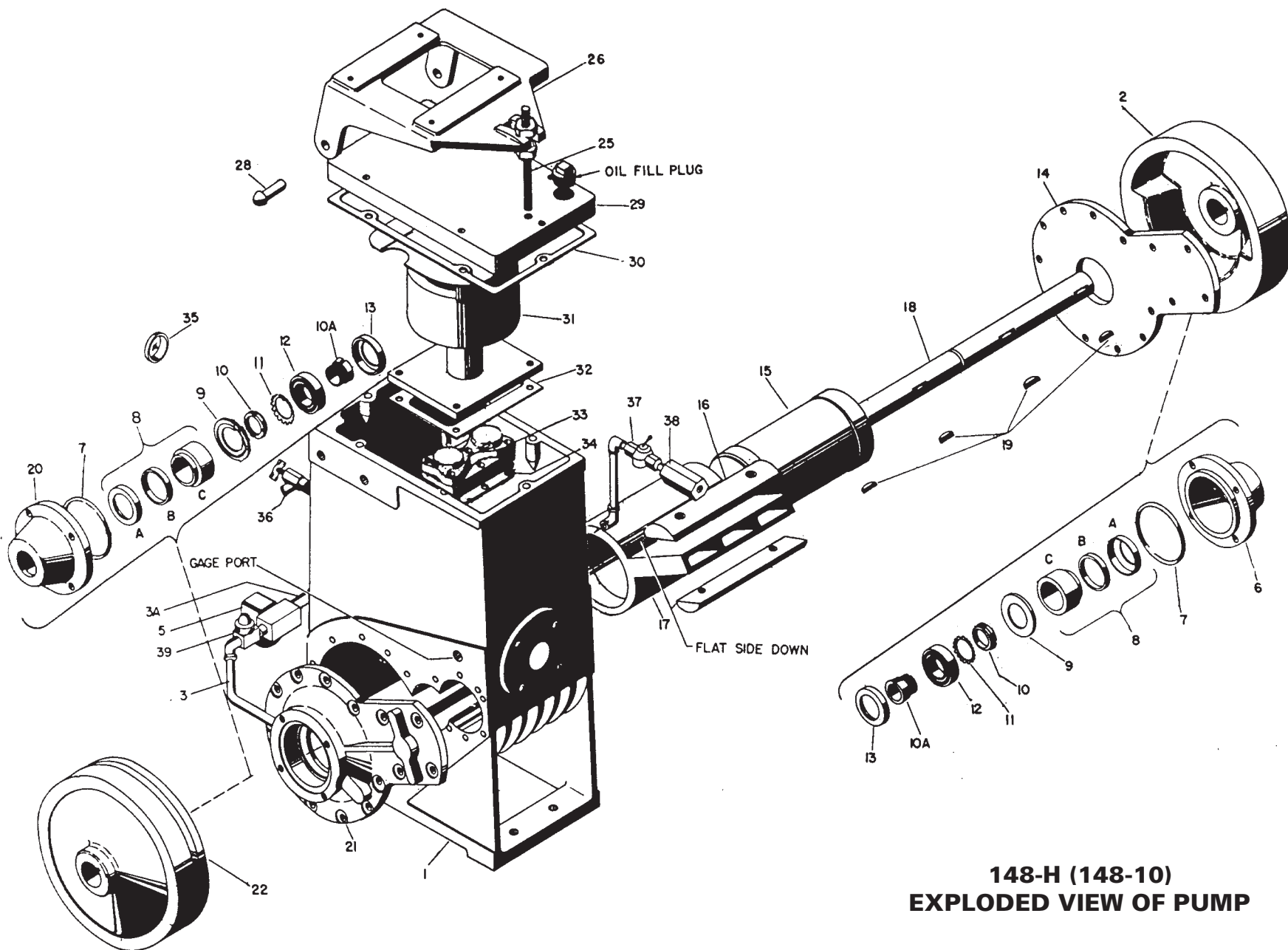

**148-H (148-10)  
EXPLODED VIEW OF PUMP**



# MODEL 149-H11 MICROVAC PUMP LOT NO. SCC-79862 FUTURE

| SYM | PART NO.     | DESCRIPTION                 | REF. DWG/<br>COMP. LIT. | QTY | UM | RSP |
|-----|--------------|-----------------------------|-------------------------|-----|----|-----|
| 1   | F-263-477-3  | Pump Housing                |                         | 1   | EA |     |
| 2   | C-262-165-7  | Flywheel                    |                         | 1   | EA |     |
| 3   | C-262-199-1  | End Cap                     |                         | 1   | EA |     |
| 4   | 085-014-704  | "O" Ring, End Cap           |                         | 2*+ | EA | ✓   |
| 5   | 085-029-599  | Rotary Oil Seal             |                         | 2*+ | EA | ✓   |
| 6   | 018-005-006  | Lock Nut                    |                         | 2+  | EA |     |
| 7   | 018-005-007  | Lock Washer                 |                         | 2+  | EA |     |
| 8   | 085-019-247  | Ball Bearing, Double Row    |                         | 2+  | EA |     |
| 9   | A-264-305-1  | Bearing Shim                |                         | 1+  | EA |     |
| 10  | A-262-196-2  | Shaft Shoulder Ring         |                         | 1+  | EA |     |
| 11  | D-262-200-1  | Side Cover                  |                         | 2   | EA |     |
| 12  | B-247-389-13 | Hinge Bar                   |                         | 2+  | EA |     |
| 13  | C-247-392-5  | Piston & Slide              |                         | 1+  | EA |     |
| 14  | C-247-394-8  | Eccentric                   |                         | 1+  | EA |     |
| 15  | C-263-211-2  | Shaft                       |                         | 1+  | EA |     |
| 16  | A-264-522-1  | Woodruff Key #15            |                         | 2   | EA |     |
| 17  | A-264-523-1  | Woodruff Key #127           |                         | 1+  | EA |     |
| 18  | D-411-057-3  | Flywheel Guard Ass'y        |                         | 1   | EA |     |
| 20  | B-287-918-7  | Swivel Block                |                         | 2   | EA |     |
| 21  | C-287-917-6  | Motor Platform              |                         | 1   | EA |     |
| 23  | B-263-249-4  | Eyebolt Base                |                         | 1   | EA |     |
| 24  | B-263-250-7  | Motor Support Eyebolt       |                         | 1+  | EA |     |
| 27  | C-262-167-7  | Pulley                      |                         | 1   | EA |     |
| 28  | 085-005-838  | Bushing, 1 1/8" Bore        |                         | 2   | EA |     |
| 29  | F-270-042-5  | Oil Reservoir               |                         | 1   | EA |     |
| 30  | B-264-127-2  | Reservoir Cover Gasket      |                         | 1*+ | EA | ✓   |
| 31  | B-419-109-30 | Oil Reservoir Cover         |                         | 1   | EA |     |
| 32  | 085-036-101  | Oil Level Indicator         |                         | 1+  | EA |     |
| 33  | 085-038-301  | Gasket Eliminator           |                         | 1   | EA |     |
| 34  | B-264-501-2  | Oil Baffle                  |                         | 1   | EA |     |
| 35  | A-247-381-2  | Oil Separator Gasket        |                         | 1*+ | EA | ✓   |
| 36  | B-271-584-4  | Valve Assembly Consists Of: |                         | 1+  | EA |     |
| 36A | B-416-745-2  | Valve Cap                   |                         | 1*+ | EA | ✓   |

RSP = RECOMMENDED SPARE PART  
UM = UNIT OF MEASURE

# MODEL 149-H11 MICROVAC PUMP LOT NO. SCC-79862 FUTURE

| SYM | PART NO.    | DESCRIPTION   | REF. DWG/<br>COMP. LIT. | QTY | UM | RSP |
|-----|-------------|---|-------------------------|-----|----|-----|
| 36B | A-274-172-1 | Valve Spring  |                         | 3*+ | EA | ✓   |
| 36C | A-276-781-2 | Valve Clapper (Zytel)                               |                         | 3*+ | EA | ✓   |
| 36D | B-416-744-3 | Valve Seat  |                         | 1+  | EA |     |
|     | 085-019-295 | Screw Hex. Head, Cap, 5/16" X 18" X 7/8 Lg.         |                         | 2*+ | EA | ✓   |
| 37  | A-247-404-3 | Valve Plate Gasket                                  |                         | 1*+ | EA | ✓   |
| 38  | 085-030-713 | Solenoid Valve, 240/480V                            |                         | 1*+ | EA | ✓   |
| 38A | 085-030-950 | Solenoid Valve Coil, 240/480V.                      |                         | 1*+ | EA | ✓   |
| 38B | 085-030-958 | Solenoid Valve Coil, 550V.                          |                         | 1*+ | EA | ✓   |
| 39  | A-400-844-2 | Tube Oil Pipe R.H.                                  |                         | 1   | EA |     |
| 39A | A-400-845-2 | Tube Oil Pipe L.H.                                  |                         | 1   | EA |     |
| 40  | 085-033-233 | Brass Cock, 1/2" MPT                                |                         | 1   | EA |     |
| 41  | 085-021-964 | Check Valve, 1/4"                                   |                         | 1+  | EA |     |
| 41A | 085-024-134 | Check Valve Spring                                  |                         | 1*  | EA | ✓   |
| 41B | 085-024-131 | Check Valve "O" Ring (Dynamic)                      |                         | 1*  | EA | ✓   |
| 41C | 085-024-132 | Check Valve   |                         | 1*  | EA | ✓   |
| 41D | 085-024-133 | Check Valve Back-Up Ring                            |                         | 1   | EA |     |
| 42  | 085-021-810 | Ball Valve, 1/4"                                    |                         | 1+  | EA |     |
| 43  | D-411-695-2 | Belt Guard Assembly                                 |                         | 1   | EA |     |
| 44  | D-411-695-2 | Belt Guard Assembly                                 |                         | 1   | EA |     |
| 45  | 085-012-253 | Motor Pulley, 3" P.D., 3 Grooves, 1 1/8" Bore       |                         | 1   | EA |     |
| 46  | 085-013-615 | "V" Belt, 76.3 Pitch Length, Matched Set of 3 Belts |                         | 1*+ | EA | ✓   |
| 47  | A-417-251-2 | Oil Flow Indicator Ass'y Consists of the following: |                         | 1+  | EA |     |
|     | 085-029-269 | Oil Flow Indicator Body                             |                         | 1+  | EA |     |
|     | 085-034-799 | Glass Dome (Oil Flow Ind.)                          |                         | 1+  | EA |     |
|     | 085-038-817 | Gasket, Buna-N (1/32" Thk Oil Flow Indicator)       |                         | 1*+ | EA | ✓   |
|     | 085-038-818 | Gasket, Viton (1/16" Thk Oil Flow)                  |                         | 1*+ | EA | ✓   |
| 48  | B-411-692-1 | Belt Guard Bracket                                  |                         | 1   | EA |     |
| 49  | A-408-300-3 | Stand-Off   |                         | 6   | EA |     |
|     | 254-117-2   | Stokes V-Lube Pump Oil, 1 Gal. Can (Label F)        |                         | 1*+ | EA | ✓   |

RSP = RECOMMENDED SPARE PART  
UM = UNIT OF MEASURE







**SERVICES REQUIRED**

**POWER:** 7½ HP, (5.59 KW), 230/460 V,  
60 HZ., 3 PH.

**WATER:** 1½ G.P.M. (5.67 LITERS/MIN) AT  
70°F (21°C) TO 80°F (27°C)

**PUMP NET WT.** 950 LB.  
431 KG.

**MOTOR, 7½ HP, (5.59KW), 1800 RPM,  
230/460 VOLTS, 60 CY.  
3 PH. (STD.)**

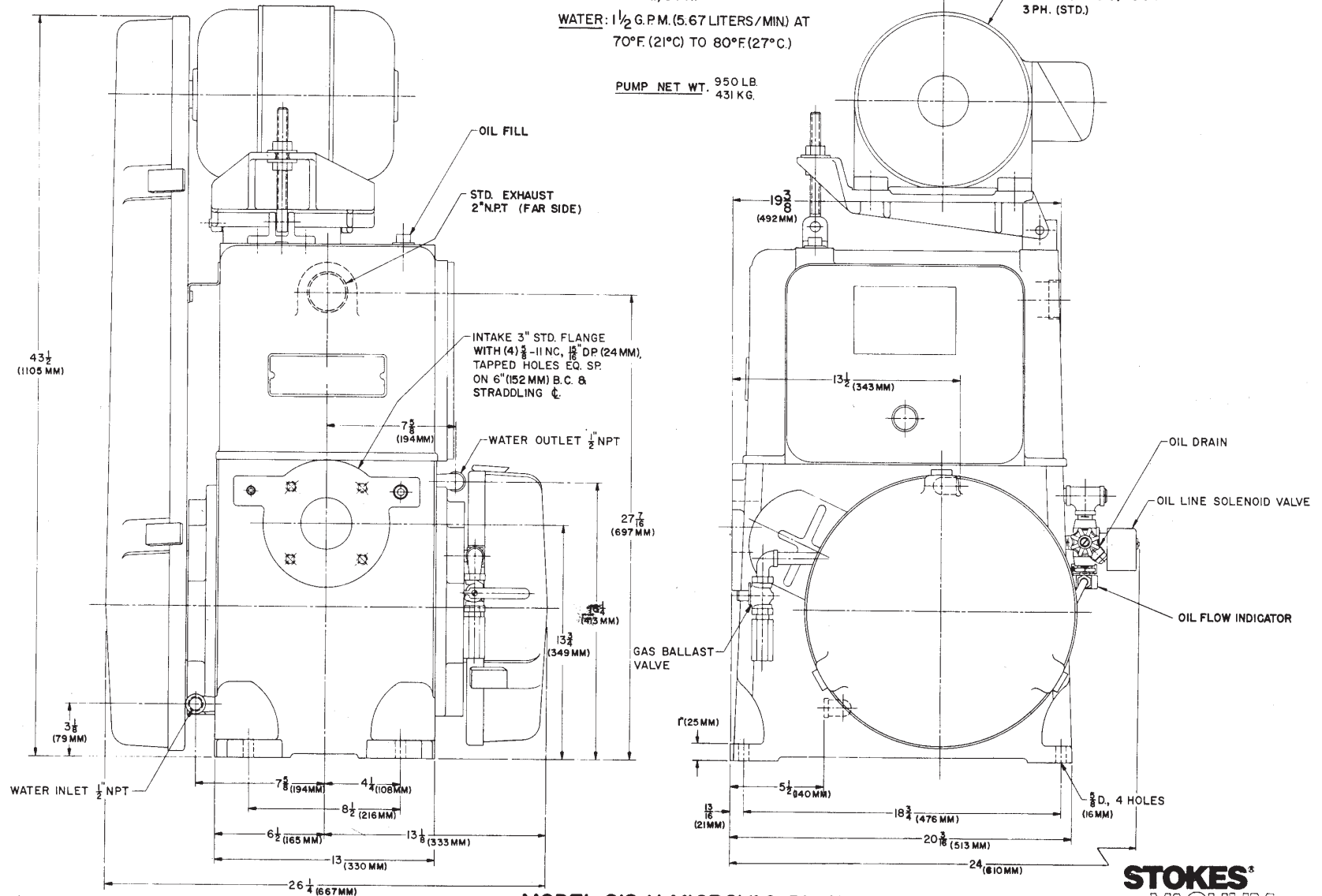

**MODEL 212-H MICROVAC PUMP**

**STOKES®  
VACUUM**

E-279-203-22

# MODEL 212-H11 MICROVAC PUMP

## LOT NO. SCC-79878

| SYM | PART NO.      | DESCRIPTION  | REF. DWG/<br>COMP. LIT. | QTY | UM | RSP |
|-----|---------------|--|-------------------------|-----|----|-----|
| 1   | F-263-842-11  | Pump Housing   |                         | 1   | EA |     |
| 2   | C-266-169-27  | Flywheel W/Dodge Taper Lock #2517 1-3/4" Bore        |                         | 1+  | EA |     |
| 3   | C-262-315-5   | End Cap  |                         | 2+  | EA |     |
| 4   | 085-019-755   | "O" Ring, 4-7/8" ID X 5-1/8" OD X.139" Sect.         |                         | 2*+ | EA | ✓   |
| 5   | 085-029-600   | Rotary Oil Seal                                      |                         | 2*+ | EA | ✓   |
| 6   | 085-019-492   | Lock Nut   |                         | 2+  | EA |     |
| 7   | 085-019-491   | Lock Washer  |                         | 2+  | EA |     |
| 8   | 085-019-757   | Ball Bearing   |                         | 2+  | EA |     |
| 9   | A-262-318-003 | Shaft Shoulder Ring                                  |                         | 1+  | EA |     |
| 10  | A-264-540-1   | Bearing Shim   |                         | 1+  | EA |     |
| 11  | D-262-508-18  | Side Cover, Drive End                                |                         | 1+  | EA |     |
| 11A | D-262-508-19  | Side Cover, Dead End                                 |                         | 1   | EA |     |
| 12  | B-297-857-4   | Hinge Bar  |                         | 2+  | EA |     |
| 13  | C-243-595-11  | Piston & Slide                                       |                         | 1+  | EA |     |
| 14  | C-278-575-1   | Eccentric  |                         | 1+  | EA |     |
| 15  | D-252-616-12  | Shaft  |                         | 1+  | EA |     |
| 16  | A-264-524-1   | Woodruff Key #G                                      |                         | 2+  | EA |     |
| 17  | A-408-324-5   | Key Eccentric  |                         | 1+  | EA |     |
| 20  | D-411-381-2   | Belt Guard Assembly                                  |                         | 1   | EA |     |
| 21  | C-266-169-25  | Pulley W/Dodge Taper Lock Bushing #2517, 1-3/4" Bore |                         | 1   | EA |     |
| 25  | B-286-122-6   | Swivel Block   |                         | 1   | EA |     |
| 26  | C-299-089-8   | Motor Platform                                       |                         | 1+  | EA |     |
| 27  | B-263-249-4   | Eyebolt Base   |                         | 1   | EA |     |
| 28  | B-263-250-7   | Motor Support Eyebolt                                |                         | 1+  | EA |     |
| 31  | 085-036-101   | Sight Glass Level (Oil Res Cover)                    |                         | 1   | EA |     |
| 32  | B-419-109-29  | Oil Reservoir Cover                                  |                         | 1   | EA |     |
| 33  | B-264-127-2   | Reservoir Cover Gasket                               |                         | 1*+ | EA | ✓   |
| 34  | F-404-521-13  | Oil Reservoir  |                         | 1   | EA |     |
| 35  | B-246-765-2   | Housing Gasket                                       |                         | 1*+ | EA | ✓   |
| 35A | 085-038-301   | Gasket Eliminator                                    |                         | 1   | EA |     |
| 36  | B-264-504-3   | Oil Baffle   |                         | 1+  | EA |     |
| 37  | B-246-763-2   | Valve Cover Plate Gasket                             |                         | 1*+ | EA | ✓   |

RSP = RECOMMENDED SPARE PART  
UM = UNIT OF MEASURE

# MODEL 212-H11 MICROVAC PUMP

## LOT NO. SCC-79878

| SYM | PART NO.    | DESCRIPTION  | REF. DWG/<br>COMP. LIT. | QTY | UM | RSP |
|-----|-------------|--|-------------------------|-----|----|-----|
|     |             |  |                         |     |    |     |
| 38  | 263-840-004 | Valve Assembly Consists Of:                        |                         | 2   | EA |     |
| 38A | B-403-636-2 | Valve Seat   |                         | 2+  | EA |     |
| 38B | B-403-626-3 | Valve Cap  |                         | 2+  | EA |     |
| 38C | A-276-781-2 | Valve Disc   |                         | 4*+ | EA | ✓   |
| 38D | A-274-172-1 | Valve Spring                                       |                         | 4*+ | EA | ✓   |
| 39  | A-243-926-2 | Valve Plate Gasket                                 |                         | 2*+ | EA | ✓   |
|     |             |  |                         |     |    |     |
| 40  | 085-030-713 | Solenoid Valve, 1/4" NPT                           |                         | 1*+ | EA | ✓   |
| 40A | 085-030-950 | Solenoid Valve Coil, 240/480V                      |                         | 1*+ | EA | ✓   |
| 40B | 085-030-958 | Solenoid Valve Coil, 550V                          |                         | 1*+ | EA | ✓   |
| 41A | A-400-829-4 | Tube - Oil Piping R.H.                             |                         | 1   | EA |     |
| 41B | A-400-830-3 | Tube - Oil Piping L.H.                             |                         | 1   | EA |     |
| 42  | 085-033-233 | Brass Cock, 1/2" MPT                               |                         | 1   | EA |     |
| 43  | 085-021-811 | Ball Valve, 3/8" MPT                               |                         | 1+  | EA |     |
| 44  | 085-021-965 | Check Valve, 3/8" MPT                              |                         | 1+  | EA |     |
| 45  | 085-024-138 | Spring for Check Valve                             |                         | 1*+ | EA | ✓   |
| 46  | 085-024-135 | "O" Ring Kit for Check Valve                       |                         | 1*+ | EA | ✓   |
| 47  | 085-027-308 | Motor Pulley, 3 Groove.                            |                         | 1   | EA |     |
| 48  | 085-013-669 | "V" Belts Matched set of 3.                        |                         | 1*+ | EA | ✓   |
| 52  | A-296-264-7 | Shaft Shoulder Ring                                |                         | 1   | EA |     |
|     |             |  |                         |     |    |     |
| 56  | A-417-251-2 | Oil Flow Indicator Assy Consists of the following: |                         | 1+  | EA |     |
|     | 085-029-269 | Oil Flow Indicator Body                            |                         | 1+  | EA |     |
|     | 085-034-799 | Glass Dome (Oil Flow Indicator)                    |                         |     | EA |     |
|     | 085-038-817 | Gasket, Buna - N, (1/32 Thk.)(Oil Flow Indicator)  |                         | 1*+ | EA | ✓   |
|     | 085-038-818 | Gasket, Viton, (1/16 Thk.)(Oil Flow Indicator)     |                         | 1*+ | EA | ✓   |
|     |             |  |                         |     |    |     |
| 57  | B-411-374-1 | Belt Guard Bracket                                 |                         | 1   | EA |     |
| 58  | D-410-736-2 | Flywheel Guard Assembly                            |                         | 1   | EA |     |
| 59  | A-298-799-1 | Spacer Stud  |                         | 6   | EA |     |
|     |             |  |                         |     |    |     |

RSP = RECOMMENDED SPARE PART  
UM = UNIT OF MEASURE



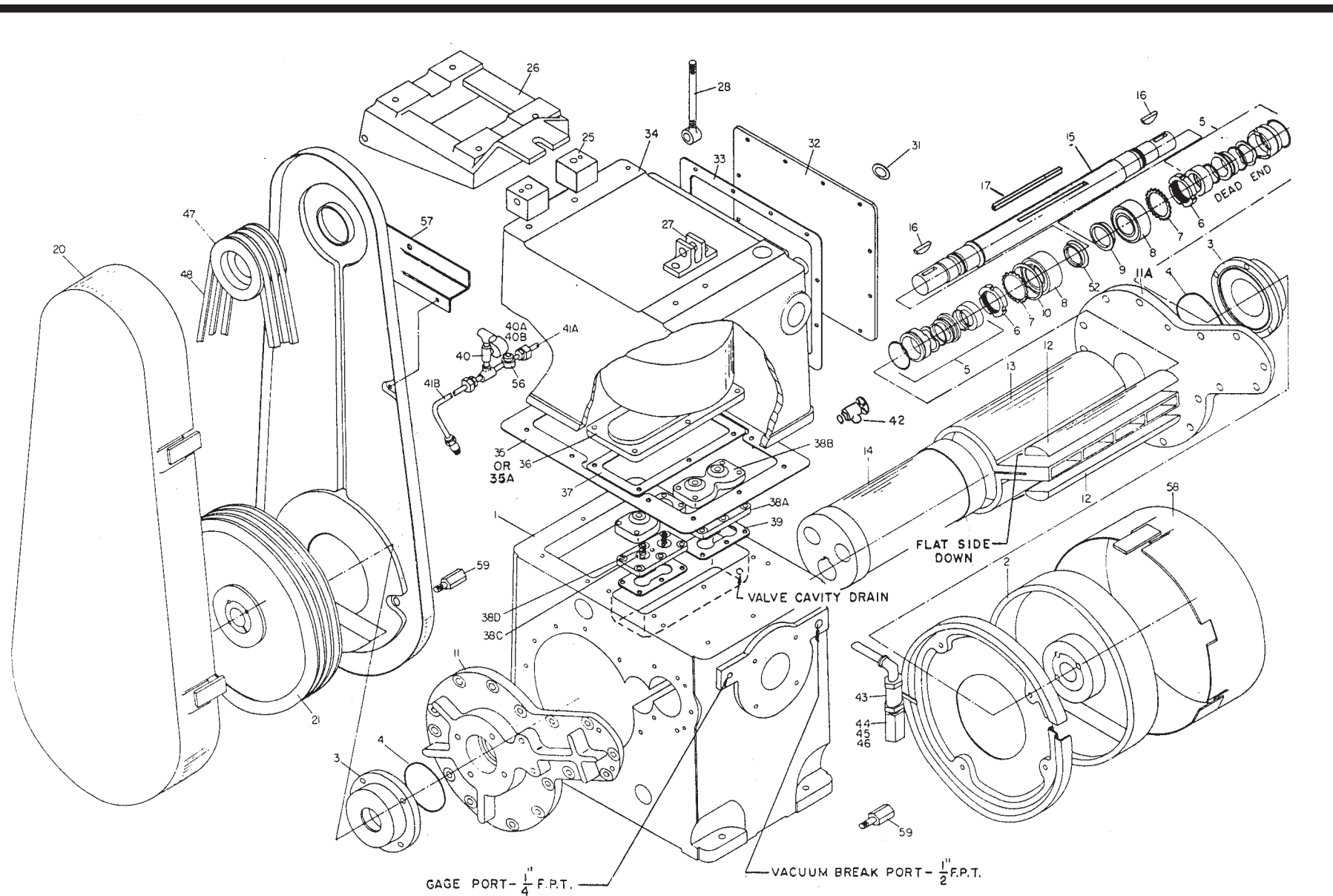

EXPLODED VIEW (212-11)

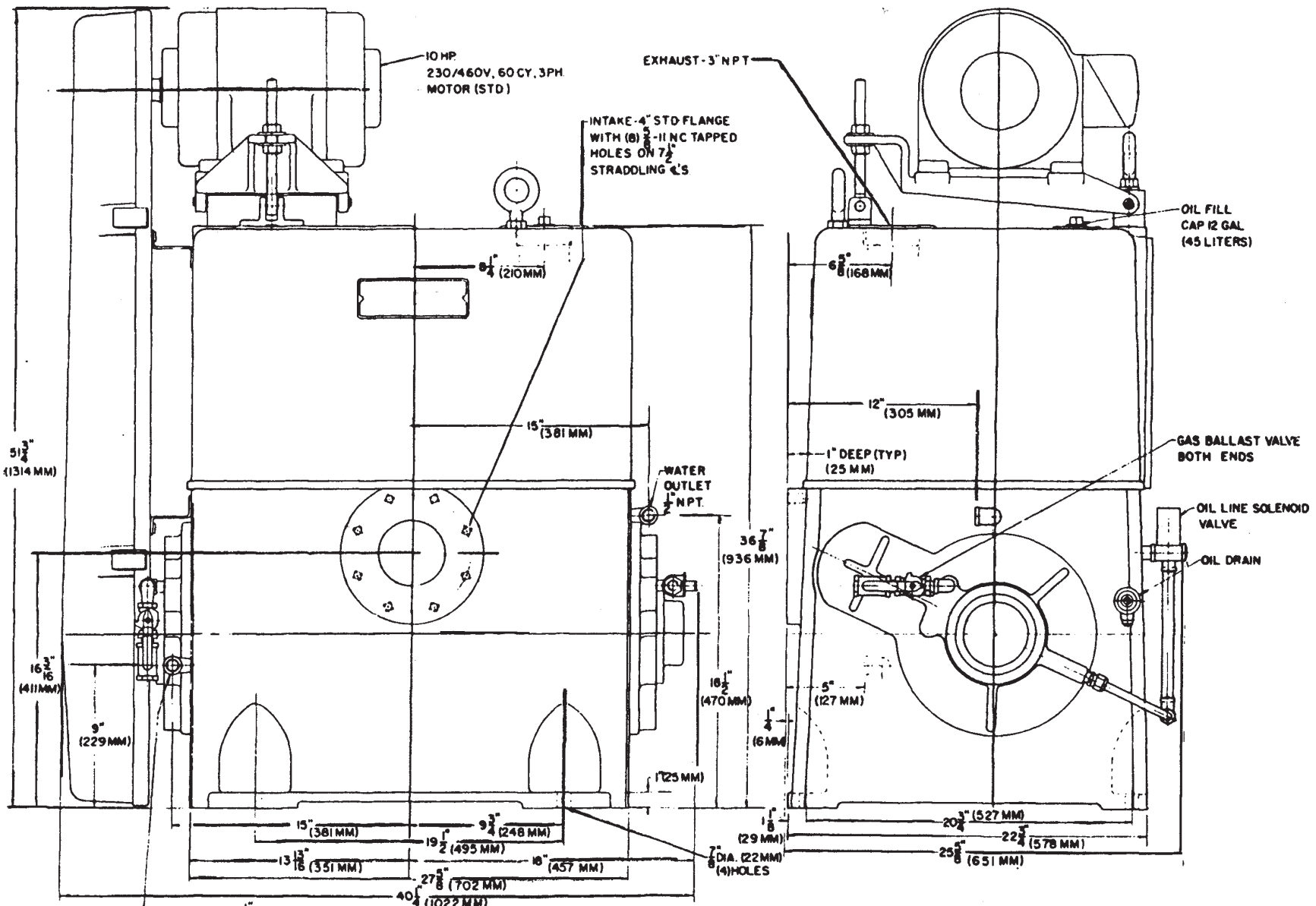

**MODEL 412-H MICROVAC PUMP**



# MODEL 412-H11 MICROVAC PUMP

## LOT NO. SCC-79924

| SYM | PART NO.     | DESCRIPTION                                     | REF. DWG/<br>COMP. LIT. | QTY | UM | RSP |
|-----|--------------|---|-------------------------|-----|----|-----|
| 1   | F-408-867-4  | Belt Guard Assembly                             |                         | 1   | EA |     |
| 2   | B-408-306-6  | Bracket   |                         | 1   | EA |     |
| 3   | B-408-306-5  | Bracket   |                         | 1   | EA |     |
| 4   | C-268-783-5  | Pulley W/Taper Lock Bushing (021-4-17)          |                         | 1+  | EA |     |
| 4A  | 085-012-593  | Motor Pulley, 4 Groves                          |                         | 1+  | EA |     |
| 4B  | 085-013-726  | "V" Belt Matched Set of 4 I.N.D B-105           |                         | 1*+ | EA | ✓   |
| 5   | C-262-315-5  | End Cap - Drive End                             |                         | 1+  | EA |     |
| 6   | 085-019-755  | "O" Ring, 4 7/8" ID X 5 1/8" OD x .139 Sect.    |                         | 1*+ | EA | ✓   |
| 7   | 085-029-600  | Rotary Oil Seal                                 |                         | 1*+ | EA | ✓   |
| 8   | 085-019-492  | Lock Nut  |                         | 2+  | EA |     |
| 9   | 085-019-491  | Lock Washer                                     |                         | 2+  | EA |     |
| 11  | 085-019-757  | Ball Bearing                                    |                         | 2+  | EA |     |
| 12  | A-262-508-20 | Side Cover, Drive End                           |                         | 1+  | EA |     |
| 12A | A-262-508-21 | Side Cover, Dead End                            |                         | 1+  | EA |     |
| 13  | A-262-318-3  | Shaft Shoulder Ring                             |                         | 2+  | EA |     |
| 14  | A-264-524-1  | Woodruff Key, 3/8" X 1/2" X .375" Wide          |                         | 1+  | EA |     |
| 15  | A-408-324-5  | Key Eccentric                                   |                         | 2+  | EA |     |
| 16  | D-262-992-5  | Shaft   |                         | 1+  | EA |     |
| 17  | C-243-595-11 | Piston & Slide                                  |                         | 2+  | EA |     |
| 18  | B-297-857-4  | Hinge Bar                                       |                         | 4+  | EA |     |
| 19  | C-252-459-1  | Solid Eccentric                                 |                         | 1+  | EA |     |
| 20  | A-268-788-1  | Hinge Bar Spacer                                |                         | 1+  | EA |     |
| 21  | 085-021-745  | Nylock S.H. Cap Screw, 1/4" - 20" x 1-1/4" Long |                         | 6+  | EA |     |
| 22  | C-264-785-2  | Bearing Ring                                    |                         | 1+  | EA |     |
| 23  | 085-033-232  | Roller Bearing                                  |                         | 1+  | EA |     |
| 24  | A-270-231-1  | Retaining Pin                                   |                         | 1+  | EA |     |
|     | A-243-926-2  | Valve Plate Gasket                              |                         | 4*+ | EA | ✓   |
| 26  | 263-840-004  | Valve Assembly Consists Of:                     |                         | 4+  | EA |     |
| 26A | B-403-626-3  | Valve Cap                                       |                         | 4+  | EA |     |
| 26B | A-274-172-1  | Spring  |                         | 8*+ | EA | ✓   |
| 26C | A-276-963-2  | Valve Clapper (Zytel)                           |                         | 8*+ | EA | ✓   |
| 26D | B-403-636-2  | Valve Seat                                      |                         | 4+  | EA |     |

RSP = RECOMMENDED SPARE PART  
UM = UNIT OF MEASURE

# MODEL 412-H11 MICROVAC PUMP

## LOT NO. SCC-79924

| SYM                        | PART NO.     | DESCRIPTION                                   | REF. DWG/<br>COMP. LIT. | QTY | UM | RSP |
|----------------------------|--------------|---|-------------------------|-----|----|-----|
| 27                         | B-269-037-1  | Oil Separator Gasket                          |                         | 1*+ | EA | ✓   |
| 28                         | D-269-256-5  | Oil Separator                                 |                         | 1+  | EA |     |
| 29                         | C-269-043-1  | Housing Gasket                                |                         | 1*+ | EA | ✓   |
| 29A                        | 085-038-301  | Gasket Eliminator                             |                         | 1*+ | EA | ✓   |
| 30                         | F-299-66-24  | Oil Reservoir (Welded)                        |                         | 1   | EA |     |
| 31                         | B-248-411-11 | Cover Plate Gasket                            |                         | 1*+ | EA | ✓   |
| 32                         | B-419-109-28 | Cover Plate                                   |                         | 1   | EA |     |
| 33                         | 085-036-101  | Oil Level Indicator                           |                         | 1   | EA |     |
| 34                         | 085-035-996  | Motor Bracket Pin                             |                         | 2   | EA |     |
| 35                         | B-287-950-3  | Swivel Block                                  |                         | 2   | EA |     |
| 36                         | C-288-202-5  | Motor Platform                                |                         | 1   | EA |     |
| 38                         | B-263-249-4  | Eye Bolt Base                                 |                         | 1   | EA |     |
| 39                         | B-263-250-7  | Motor Support Eyebolt                         |                         | 1+  | EA |     |
| 41                         | C-278-575-1  | Hollow Eccentric                              |                         | 1+  | EA |     |
| 42                         | 085-019-755  | "O" Ring, 4 7/8" ID X 5 1/8" OD x .139" Sect. |                         | 1*  | EA | ✓   |
| 43                         | C-264-789-03 | End Cap - Dead End                            |                         | 1   | EA |     |
| 44                         | F-262-712-25 | Pump Housing                                  |                         | 1+  | EA |     |
| <b>OIL LINE COMPONENTS</b> |              |   |                         |     |    |     |
| 45                         | A-269-286-13 | Tubing, 5/8" OD X 16 1/8" Long                |                         | 2   | EA |     |
| 46                         | 085-021-037  | Flow Indicator                                |                         | 1+  | EA |     |
| 47                         | 085-036-053  | Brass Pipe, 1/2" NPT X 8 1/4" Long            |                         | 1   | EA |     |
| 48                         | 085-035-837  | Solenoid Valve 1/2" IPS 220/240V              |                         | 1*+ | EA | ✓   |
| 48A                        | 085-029-430  | Solenoid Valve Coil 220/440V 50/60 CY.        |                         | 1*+ | EA | ✓   |
| 48B                        | 085-029-427  | Sol. Valve Coil 550V, 60 CY,                  |                         | 1*+ | EA | ✓   |
| 48C                        | 085-029-431  | Sol. Valve Coi1 110V 50/60 CY                 |                         | 1*+ | EA | ✓   |
| 49                         | 085-021-811  | Ball Valve, 3/8" IPS                          |                         | 2+  | EA |     |
| 50                         | 085-021-965  | Check Valve, 3/8 IPS                          |                         | 2+  | EA |     |
| 50A                        | 085-024-138  | Spring  |                         | 2*+ | EA | ✓   |
| 50B                        | 085-024-135  | Dynamic "O" Ring                              |                         | 2*+ | EA | ✓   |
| 50C                        | 085-024-136  | Static "O" Ring                               |                         | 2   | EA |     |
| 51                         | 085-033-233  | Brass Cock, 1/2" MPT                          |                         | 1   | EA |     |

RSP = RECOMMENDED SPARE PART  
UM = UNIT OF MEASURE



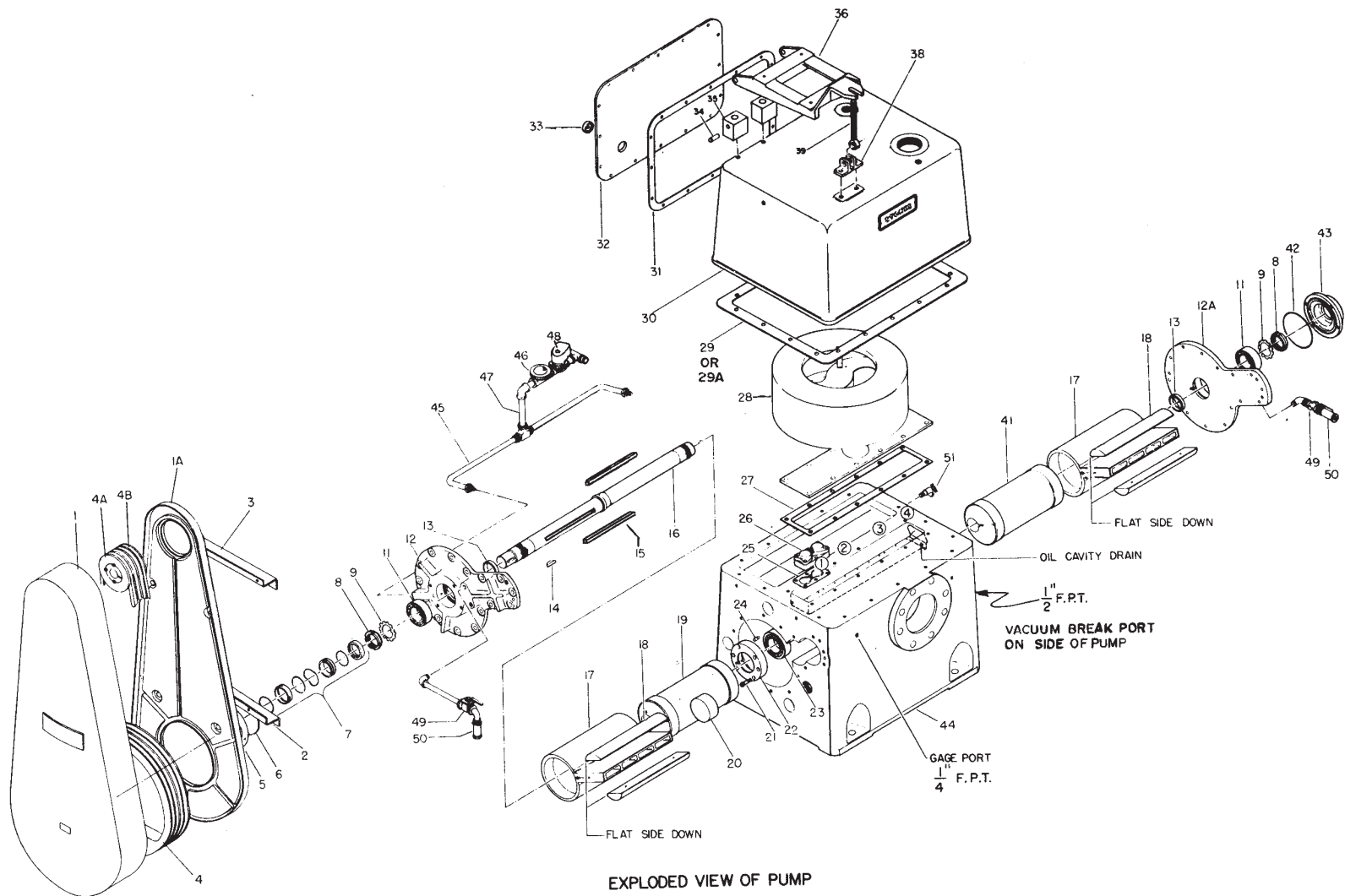

**SUMMARY****MICROVAC PUMP MAJOR ATTENTION ITEMS**

1. Check oil level, oil flow and condition of the pump oil periodically. If oil is contaminated, change it and if very dirty, clean the oil reservoir and exhaust valve chamber. Oil should be changed as often as necessary to maintain low blank-off and effective lubrication.
2. Replace exhaust valve springs and exhaust valve disc at least every 6 months when pump is operated 8 hours per day. Clean out any sludge accumulation in oil reservoir.
3. If the gas ballast feature is used regularly, it may be necessary to replace the check valve at least every 6 months.
4. To insure for maximum gas ballast efficiency, check outlet water temperature on jacketed models to make sure the pump is running warm. Oil in the pump reservoir should be approximately 140 degrees to 160 degrees F.(60-71 Deg. C.) for best gas ballast efficiency.
5. If pump incorporates an external oil mist separator, periodically drain off any accumulated dirty oil and discard. This will maintain the efficiency of the unit and extend the life of the element.
6. Check oil solenoid valve periodically for sludge and/or foreign particles accumulation by disassembling and cleaning. If valve sticks in open position, oil can be sucked into pump at shut down. If valve sticks in closed position, insufficient lubrication results and pump can be damaged. Disassemble valve, inspect and clean. Replace parts needing replacement.

***NOT A LOT OF CARE...JUST THE RIGHT KIND...AT THE RIGHT TIME.***

**USE THE STOKES VACUUM PREVENTIVE MAINTENANCE CHECK LIST  
THAT FOLLOWS.**



**MICROVAC PUMP PREVENTIVE MAINTENANCE CHECK LIST**

USER \_\_\_\_\_ PUMP MODEL NO. \_\_\_\_\_

PUMP LOT NO. \_\_\_\_\_ SERIAL NO. \_\_\_\_\_

DATE PUMP INSTALLED \_\_\_\_/\_\_\_\_/\_\_\_\_

| <b>MAJOR ATTENTION ITEMS</b>   | <b>DATE<br/>INSTALLED</b> | <b>FIRST<br/>INSPECTION<br/>DUE</b> | <b>WAS<br/>M.A.I.<br/>ACCOMP.</b> | <b>COMMENTS</b> |
|--|---------------------------|-------------------------------------|-----------------------------------|-----------------|
| 1. CHECK OIL LEVEL, OIL FLOW AND CONDITION OF THE PUMP OIL. SCHEDULE OIL CHANGE TO SUIT YOUR APPLICATION                             |                           |                                     |                                   |                 |
| 2. REPLACE EXHAUST VALVE SPRINGS AND EXHAUST VALVE DISCS. CLEAN OUT ANY SLUDGE IN OIL RESERVOIR. EVERY SIX MONTHS.                   |                           |                                     |                                   |                 |
| 3. CHECK THE SPRING IN THE GAS BALLAST CHECK VALVE. REPLACE CHECK VALVE IF BROKEN. THREE MONTH INTERVALS RECOMMENDED.                |                           |                                     |                                   |                 |
| 4. CHECK OUTLET WATER TEMPERATURE ON JACKETED MODELS TO MAKE SURE THE PUMP IS RUNNING WARM. (140 TO 160 DEG. F.)(60 – 71 DEG. C.)    |                           |                                     |                                   |                 |
| 5. IF PUMP INCORPORATES AN EXTERNAL OIL MIST SEPERATOR, DRAIN OFF ANY ACCUMULATED DIRTY OIL.   |                           |                                     |                                   |                 |
| 6. FLUSH THE PUMP PERIODICALLY USING A DETERGENT TYPE OIL. SIX MONTH INTERVAL RECOMMENDED.   |                           |                                     |                                   |                 |
| 7. CHECK SOLENOID VALVE FOR SLUDGE AND/OR FOREIGN PARTICLES ACCUMLATION. IF VALVE STICKS, DISASSEMBLE, CLEAN AND REPLACE WORN PARTS. |                           |                                     |                                   |                 |

For **FAST** Part's Sales and Service  
for your Stokes Vacuum  
Equipment, call the office nearest  
you!!!

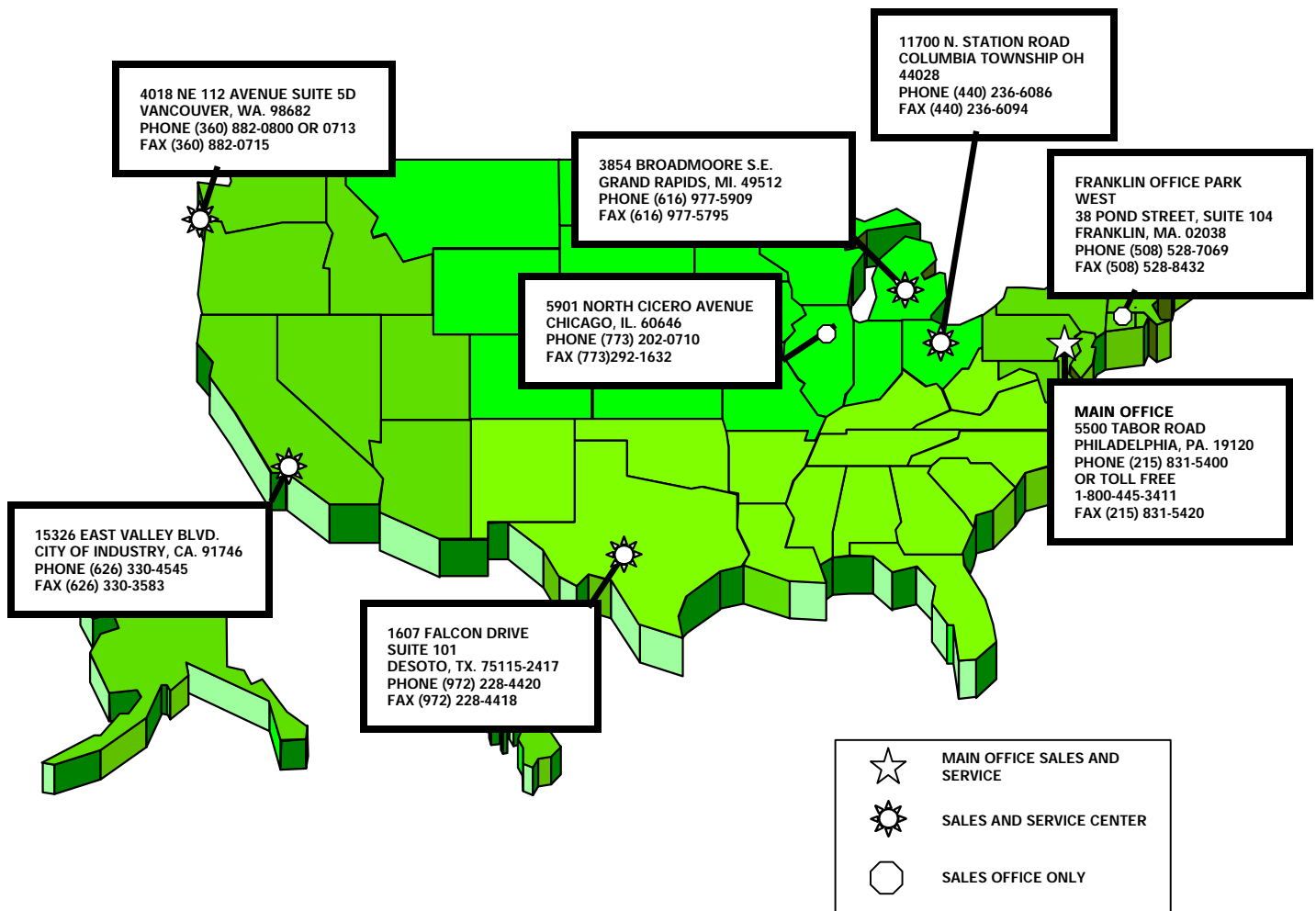

## PARTS ORDERING INFORMATION

The Stokes Customer Service Department is organized to assist you in keeping your equipment operating and to provide necessary parts as spares for your critical inventory as well as replacement parts as needed.

For faster service when ordering parts, please observe the following procedure:

- ✓ Order by part number shown on the parts list.
- ✓ Always include the model, lot and serial number of the equipment. These numbers can be found on the nameplate.
- ✓ Use the same nomenclature as shown on reference drawings and parts list. Also refer to drawing numbers and parts list symbol numbers whenever possible.
- ✓ When ordering electrical parts and solenoid operated valves, be sure to specify voltage, cycles and phase as well as the part number.

<http://www.stokesvacuum.com>

For **FAST** Part's Sales and Service  
for your Stokes Vacuum  
Equipment, call the office nearest  
you!!!

FOR THE INTERNATIONAL SALES AND SERVICE CENTER  
NEAREST YOU PLEASE CALL 1-800-445-3411 AND ASK FOR  
OUR INTERNATIONAL CUSTOMER SERVICE DEPARTMENT.

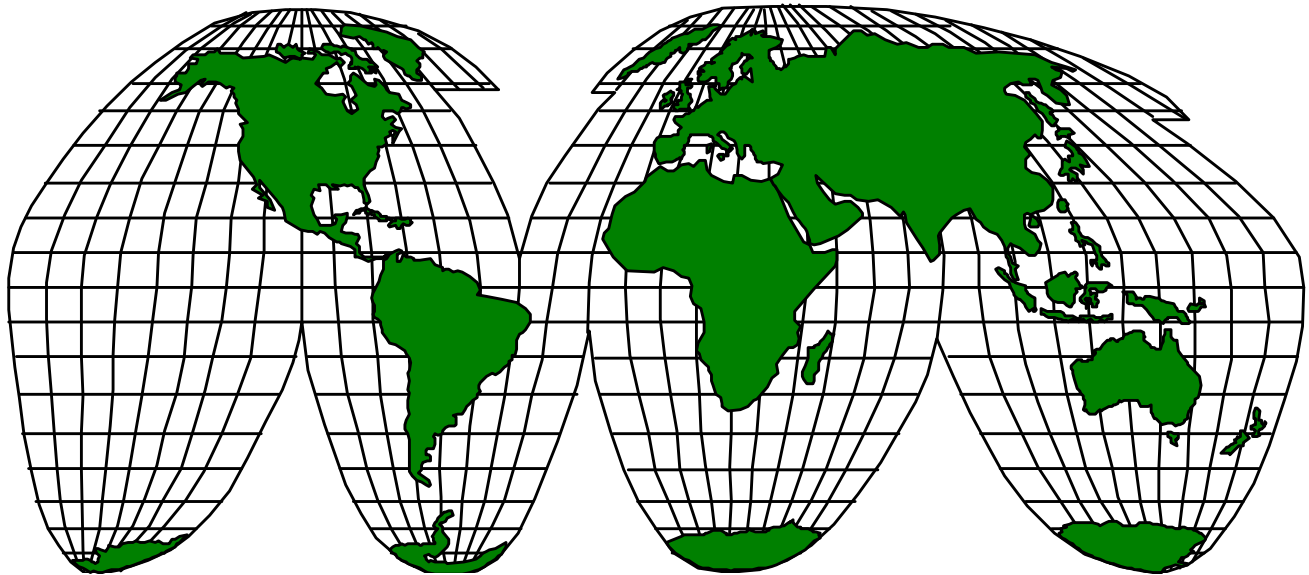

### PARTS ORDERING INFORMATION

The Stokes Customer Service Department is organized to assist you in keeping your equipment operating and to provide necessary parts as spares for your critical inventory as well as replacement parts as needed.

For faster service when ordering parts, please observe the following procedure:

- ✓ Order by part number shown on the parts list.
- ✓ Always include the model, lot and serial number of the equipment. These numbers can be found on the nameplate.
- ✓ Use the same nomenclature as shown on reference drawings and parts list. Also refer to drawing numbers and parts list symbol numbers whenever possible.
- ✓ When ordering electrical parts and solenoid operated valves, be sure to specify voltage, cycles and phase as well as the part number.



## PARTS ORDERING INFORMATION

The Stokes Customer Service Department is organized to assist you in keeping your equipment operating and to provide necessary parts as spares for your critical inventory as well as replacement parts as needed.

A wide range of critical and wear parts are stocked for your convenience. Special parts, not normally replaced, are not always stocked and Stokes is prepared to manufacture these on a priority basis.

In spite of our very effective Inventory Control System, unusual demands may find us out of stock on critical items and we strongly recommend that you carry an inventory of critical parts, as well as those special parts relative to your equipment. Wear items, those recommended for your inventory, are noted on the Parts List by an asterisk (\*). Having these parts readily available will assure maximum "Up-Time" for your equipment and minimum loss of production.

Those parts, marked by a plus sign (+) in the quantity column, are normally stocked in Philadelphia, with smaller quantities in our Service Centers around the country, (Dallas, Chicago, Los Angeles). If your parts list is not clear or seems to be incomplete, please contact the Stokes Customer Service Department, 5500 Tabor Road Philadelphia Pa. 19120, for an updated or clarified list.

For faster service when ordering parts, please observe the following procedure:

- 1) Order by part number shown on the parts list.
- 2) Always include the model, lot and serial number of the equipment. These numbers are listed in the instruction manual, on the parts list, and also stamped on the nameplate of the machine.
- 3) Use the same nomenclature as shown on reference drawings and parts list. Also refer to drawing numbers and parts list symbol numbers whenever possible.
- 4) When ordering electrical parts and solenoid-operated valves, be sure to specify voltage, cycles and phase as well as the part number.
- 5) For faster service send parts orders directly to Stokes Vacuum Inc., Customer Service Dept., 5500 Tabor Road, Philadelphia, Pa. 19120 or contact Customer Service Dept. at 1-800-445-3411.

## Warranty and Field Service Policy

### INTRODUCTION

The following describe Stokes warranty and service policies. These, in connection with the operating instructions attached, were produced for your benefit.

Maximum results can only be achieved if your technical staff thoroughly familiarizes itself with all features of Stokes equipment, many of which are unique. For this purpose Stokes will provide demonstration and instruction services whenever necessary and will gladly answer any questions that may arise.

Please read the following subject matter for further details of services that are available and provisions under which they can be supplied.

### DEMONSTRATION OF NEW EQUIPMENT

1. With certain Stokes equipment, demonstration service is included for the purpose of checking the installation and operation of the equipment. These services include one round trip from the factory or district service office and include traveling and living expenses. The specified time will be on the basis of an eight hour day (Monday through Friday), holidays excluded.
2. If additional demonstration services are required, a charge will be made for the additional time and expenses.
3. Stokes equipment is shipped with a normal amount of disassembly. It is the responsibility of the purchaser to provide suitable foundations and have the equipment fully assembled, and to have all wiring and piping completed in accordance with Stokes installation instructions before requesting demonstration. At least one week advance notice is requested in order to insure having qualified personnel available.
4. Stokes' responsibility extends only to the equipment it has supplied. In the event that ancillary or auxiliary items are added, the operation of these items by Stokes' Service Personnel will be at the Purchaser's risk.

### GENERAL SERVICE POLICY

1. Stokes provides the serviceperson, upon request, for the purpose of checking machines, recommending replacement parts, overhauling, rebuilding, etc. The customer will be charged for time and expense.
2. On courtesy calls, initiated by Stokes, minor adjustments will be made and instructions given free of charge. Should the customer request service beyond what might reasonably

be defined as "major adjustments and instructions", a charge will be made for the additional time required. Should the request for additional service involve an unscheduled overnight stop-over or other unanticipated expense, the customer will also be billed for the added expenses involved.

3. Stokes servicepersons are specialists. Their primary functions are to demonstrate, to identify sources of trouble and to instruct customers' operating and maintenance personnel in methods of prevention and correction. To obtain maximum utilization of the servicepersons, customers should provide all necessary assistance in the form of movers, mechanics, operators, etc. Customers should also provide any standard tools and facilities that may be required and that cannot readily be carried by a serviceperson such as lifting equipment, electric drills, etc.

#### REBUILDING, REPAIRING AND MODIFYING STOKES EQUIPMENT

Customers interested in major overhaul and/or repair work on their existing machines should first consider the age and general condition of the equipment under consideration, the current cost of comparable new equipment and comparable design features. If it is deemed advisable to rebuild rather than replace, the equipment should be returned to the Stokes factory.

Pumps being rebuilt are thoroughly disassembled, cleaned and reassembled with new parts. The rebuilt pump is put on the test block and checked for performance. Only when acceptable performance is demonstrated, is the pump released for shipment.

Pumping units are available for rental, subject to availability, by customers who need additional pumping capacity for short periods or to fill in while the regular equipment is being repaired or rebuilt.

The cost of disassembling, cleaning and inspection is included in the price. The parts for the major repair kit used are included in the parts section of this manual. If the additional parts required or if repairs are found to be so extensive that rebuilding is considered uneconomical and the project is dropped, the customer will be invoiced a previously established fixed fee.

#### PUMPING HAZARDOUS GASES

Pumping certain gases or gaseous mixtures is hazardous. Consequently, we cannot assume responsibility for the operational safety of our pumping components. We can only alert you to this hazard and suggest procedures to minimize the possibility of an explosion.

1. The mechanical pump should be located in a safe area so that the reactive gas is unlikely to be present in the atmosphere surrounding the unit.

2. It is essential that the vacuum system, including discharge line, be free of air leaks, so that gases will not leak into or out of the system.

3. The pump should be purged with nitrogen (or other suitable inert gas) prior to, during and after operation. Purge port connections should be made at two locations: Port A - to be at the pump inlet on the pump side of the inlet line valve; Port B - to be in the discharge of the pump.

Port A (at inlet) is to be used with the inlet valve closed, but with the pump in operation. This will help reduce the percentage of reactive gas present in the unit and the discharge. When the inlet valve is open, Port A should be closed. After the evacuation is complete, the inlet valve should be closed and Port A reopened to purge the pump and to fill all voids in the pump and discharge line.

Port B (discharge) is to be used while the unit is in operation, with inlet valve open (but with Port A closed). This will assure a continuous positive flow of inert gas through the pump's discharge section to safely carry off the reactive gas being evacuated from the system. The inert gas flow must be sufficient to prevent exhaust gases from back diffusing through the exhaust line into the pump.

4. The discharge line from the vacuum pump should be vented to a suitable safe area outside of any building where it is unlikely that the reactive gas could accumulate. The work area around the pumping equipment should also be ventilated to avoid the possibility of reactive gas accumulations.
5. A suitable flame arrester should be placed in the discharge line. The discharge pipe should be marked to avoid the possibility of workmen welding, or working near the area with open flames or dangerously hot equipment.
6. While it is normally unlikely that the reactive gas will be present in the work area, insurance regulations in a given locality may require special electrical components. Where stricter electrical specifications are dictated, the main control panel for the pump(s) can be located outside the hazardous area with only the vacuum switch with its associated time delay and control relays located on the mechanical booster pump. These small electrical components do not require a very large housing and can be assembled directly on the pump in a safe enclosure. The various motor and control leads can then be fed to the pumps from a safe remote location.

# STOKES EQUIPMENT WARRANTY

| PRODUCT                     | MICROVAC PUMP  | VACUUM BLOWER             | MICROVANE PUMP  | DRY PUMP   |
|-----------------------------|--|---------------------------|---|--|
| NUMBER OF WARRANTY YEARS    | TWO YEAR   | TWO YEAR                  | ONE YEAR  | ONE YEAR   |
| PARTS CONSIDERED EXPENDABLE | EXHAUST VALVE AND GAS BALLAST SPRINGS;<br>SOLENOID VALVE COIL;<br>SHAFT SEALS;<br>"V" BELTS;<br>GASKETS. | "O" RINGS;<br>SHAFT SEALS | SOLENOID VALVE COIL;<br>SHAFT SEALS;<br>GASKETS; "O" RINGS, SHAFT SLEEVE,<br>VALVE SPRINGS,<br>EXHAUST VALVES,<br>VANES | SOLENOID VALVE COIL;<br>SHAFT SEALS;<br>GASKETS;<br>"O" RINGS,<br>SHAFT SLEEVE |

Stokes Vacuum Inc warrants every Stokes product against defects in material and workmanship for a period stated above (number of warranty years) from the date of shipment, as described in our "Condition of Sale."

Every part is covered by the warranty except normally replaceable parts that are considered expendable; their life expectancy being determined by the type of service to which the pump is subjected. However, repair or replacement of any part will be made F.O.B. seller or supplier's plant, if the part in question was defective at the time of delivery.

Stokes Vacuum Inc will honor this warranty for the period stated above (number of warranty years) from the date of shipment, when the user demonstrates that the following basic conditions have been met:

- The equipment must be properly installed and operated in accordance with the established procedures outline in the Instruction Manual supplied with the equipment.
- The equipment must be protected to prevent dirt, foreign materials and corrosive vapors from entering the intake and causing damage to the working parts.
- Service the equipment at proper intervals consistent with its usage. Use the proper grade and quality of recommended oil. Stokes "V" Lube is available in several grades to assure you of meeting the latter requirements.
- Follow preventive maintenance schedule as outlined in the Operating Instruction Manual.

Our Engineering-Advisory Services are available, at no charge, to assist the user and to insure that the user obtains the maximum performance and operating life from the "tried and proven" Stokes Vacuum Equipment. Use this service for advice regarding special or unusual applications of your equipment.

# Quality Survey

**Thank you for purchasing your equipment from Stokes Vacuum Inc. In our pursuit of complete customer satisfaction we would appreciate your comments on the usefulness and readability of this manual. Please fax (215) 831-5420 or mail this sheet to Stokes Vacuum Inc 5500 Tabor Road, Philadelphia, PA. 19120 Attn: Technical Publications Department. Your cooperation is greatly appreciated.**

Thank you again,

Stokes Model Number \_\_\_\_\_ Stokes Order Number \_\_\_\_\_

Revision Date of Manual \_\_\_\_\_

**Please Rate the Following Items**

*Compared to similar manuals, this manual is...*    \_\_\_\_\_ *Good*    \_\_\_\_\_ *Fair*    \_\_\_\_\_ *Poor*

*Ease of reading is ...*    \_\_\_\_\_ *Good*    \_\_\_\_\_ *Fair*    \_\_\_\_\_ *Poor*

*Level of information is ...*    \_\_\_\_\_ *Good*    \_\_\_\_\_ *Fair*    \_\_\_\_\_ *Poor*

*Photographs and/or Illustrations are ...*    \_\_\_\_\_ *Good*    \_\_\_\_\_ *Fair*    \_\_\_\_\_ *Poor*

*The amount of information was ...*    \_\_\_\_\_ *Good*    \_\_\_\_\_ *Fair*    \_\_\_\_\_ *Poor*

**Comments?**

---

---

---

---

---