

Chemtech Scientific provides access to this content as a courtesy.  
We do not own the content contained in this document.  
All rights and credit go directly to its rightful owners.  
[www.chemtechsci.com](http://www.chemtechsci.com)  
Call us at: 484-424-9415



# OWNER'S MANUAL FOR DRY VACUUM PUMPS MODELS: 2014 2032 / 2042 2034 / 2044 2037 / 2047



## WARNING

Be sure to properly identify intake and exhaust before using the pump. See Section 2.15



## CAUTION

Do not pump liquids with the pump. Pumping liquids will cause the pump to stop working.

INSTRUCTION  
WARNING AND CAUTION  
PLEASE READ BEFORE OPERATION

While reading your manual, please pay close attention to areas labeled:  
WARNING AND CAUTION.  
The description of each is found below.

**WARNING**  
**Warnings are given where failure to observe instruction could result in injury or death to people.**

**CAUTION**  
**Cautions are found where failure to observe the instruction could result in damage to the equipment, associated equipment and process.**

These units conform to the SI International system of units of measurement.

The following symbols (with recommendation of IEC1010 ) of warning will be found on the pump.



Caution - Refer to accompanying documents

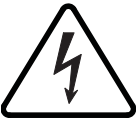

Caution - Risk of electrical shock



Caution - Hot surface

**WARNING**  
**Motor includes a self resetting thermal cutout and the pump could restart without actuation under fault condition.**

# TABLE OF CONTENTS

Section	Page
Section 01 - Safety Information	
1.10 Caution: to prevent injury	4
1.20 Caution: to reduce risk of electrical shock	4
1.30 Warning: to reduce risk of electrocution	5
1.40 Warning: to reduce risk of explosion or fire	5
Section 02 - Installation	
2.10 Environmental conditions	6
2.11 Introduction	6
2.12 Unpacking	6
2.13 Pump mounting	6
2.14 Pump location	6
2.15 Discharge provisions	7
2.16 Electrical power	8
2.17 Advanced Vapor Management (AVM)	8
2.18 Traps	8
2.19 The care of a liquid trap	9
2.20 The care of a cold trap	9
Section 03 - Operation	
3.10 Starting a Welch DRY Vacuum Pump	10
3.11 Cleanliness	10
3.12 Leak detection	10
3.13 Operating pressure range	10
3.14 The effects of unwanted vapor	10
3.15 Shutdown procedure	10
Section 04 - Maintenance	
4.10 General maintenance	11
4.11 Diaphragm removal	11
4.12 Installation of new diaphragm	11
Section 05 - Application	
5.10 Operation as a replacement for aspirators	12
5.20 Cross reference Welch DRY Pump to Water Aspirator	12
Section 06 - Specifications	
6.10 Specification Chart	13
Section 07 - Specifications	
Warranty	14
Section 08 - Drawings	
8.10 Dimensional drawing	15
8.20 Exploded view and kit for 2034, 2037 & 2044	16
8.30 Exploded view and kit for 2014, 2032, 2042 & 2047	17

## Section 1: SAFETY INFORMATION

- 1.10 Caution: To Prevent Injury...
- 1.11 Never operate this product if it has a damaged cord or plug. If it is not working properly, has been dropped, damaged or has fallen into water, please return the product to a Welch service center for examination and repair.
- 1.12 Keep the cord away from heated surfaces. All electrical products generate heat. To avoid serious burns never touch unit during or immediately after operation.
- 1.13 Never block any air openings or place it on a soft surface where the openings may be blocked. To ensure proper ventilation, keep unit a minimum of one inch from any wall or obstruction. The air openings are for ventilation of the motor inside the housing.
- 1.14 Models 2014, 2032, 2034, 2037, 2042, 2044 and 2047 are thermally protected and can automatically restart when the protector resets. Always disconnect power source before servicing.
- 1.15 Never drop or insert fingers or any other object into any openings.
- 1.16 Do not operate this product where oxygen is being administered.
- 1.17 Wear safety glasses and goggles when operating this product.
- 1.18 Use only in well ventilated areas. The motor on all pumps are totally enclosed fan cooled



### WARNING

Do not operate the pumps in an atmosphere containing flammable or explosive gases/vapors

- 1.19 Be sure to properly identify intake and discharge before using pump. See Section 2.5.

Models 2014, 2032, 2034, 2037, 2042, 2044 and 2047 have one exhaust port on the pump. See Section 2.15.



### WARNING

Remove plug from Exhaust Port before using

- 1.20 Caution: To Reduce Risk Of Electrical Shock...
- 1.21 Do not disassemble. Disassembly or attempted repairs if accomplished incorrectly can create electrical shock hazard. Refer servicing to qualified service agencies only.
- 1.22 Unit is supplied with a three pronged plug. Be sure to connect pump to a properly grounded outlet only.

- 1.30 Warning: To Reduce Risk of Electrocutation...
- 1.31 Do not use this product in or near area where it can fall or be pulled into water or other liquids.
- 1.32 Do not reach for this product if it has fallen into liquid. Unplug immediately.
- 1.33 Never operate this product outdoors in the rain or in a wet area.
- 1.40 Danger: To Reduce Risk of Explosion or Fire...
- 1.41 Do not use this pump in or near explosive atmospheres or where aerosol (spray) products are being used.
- 1.42 Do not use this product near flames.



**WARNING**

Failure to observe the above safety precautions could result in Severe bodily injury, including death in some cases

## Section 2: INSTALLATION

### 2.10 Environmental Conditions

The Pump is rated for indoor use only. Maximum altitude 2000 meters. Operating temperature range 10°C to 40°C. Maximum relative humidity of 80% for temperatures up to 31°C decreasing to 50% at 40°C. Rated for +/-10% of supply voltage. Pollution Degree 2, Installation Category II.

### 2.11 Introduction

This manual has been compiled not only for the care and maintenance of the Welch Dryfast Vacuum pump now in your possession, but as a helpful reference and guide to prevent many problems which can occur if used improperly.

### 2.12 Unpacking

Carefully remove the Dryfast Vacuum pump from the shipping case. Preserve all paperwork for future reference. If damage has occurred from shipment a claim must be filed with the carrier immediately; preserve the shipping carton for inspection by the carrier. If you are required to communicate with your dealer or Welch Vacuum be sure to include your order numbers for quick identification. Do not return the pump to the factory without obtaining returned goods authorization. \*See "Service & Support" on [www.welchvacuum.com](http://www.welchvacuum.com).

### 2.13 Pump Mounting

Rubber feet are attached to the pump casing.

### 2.14 Pump Location



#### WARNING

Don't operate this pump in an atmosphere containing flammable or explosive gas



#### WARNING

The motor is thermally protected and will automatically restart unexpectedly when the overload device resets

The Dryfast Vacuum pump should be located preferably in a clean, dry and well ventilated area. Please be sure not to block the ventilation ports located on the motor housing. The pump should be placed where the surrounding temperature remains between 10°C and 40°C (50°F and 104°F). Always check to insure the location chosen is protected from direct or indirect moisture contact. The pump should be located as closely to its system in order to utilize it most efficiently.

## 2.15 Discharge Provisions

Dryfast Vacuum Pump Models 2014, 2032, 2034, 2037, 2042 2044 and 2047 come with two hose barbs, one Intake and one Exhaust. All hose barbs and mufflers are supplied loose with the pump. The hose barb used on all models accepts 3/8" I.D. hose. By threading the hose barb in the exhaust port of the pump, a vent line can be attached which allows gases and vapors pumped through the pump to be piped from the work area into a hood. Vent lines will muffle noise coming from the vacuum pump.



### WARNING

Never block the discharge port. If the exhaust is blocked, pressure will build-up in the pump which can lead to the pump head bursting creating the potential of serious injury. Remove plug from exhaust port.



### WARNING

Remove plug from exhaust port before operating

Properly identify the intake and exhaust of the pump

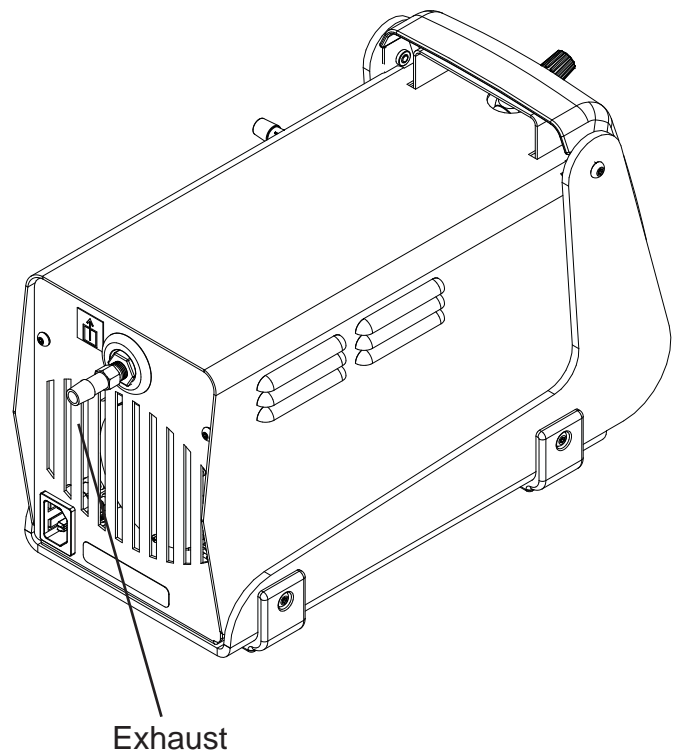
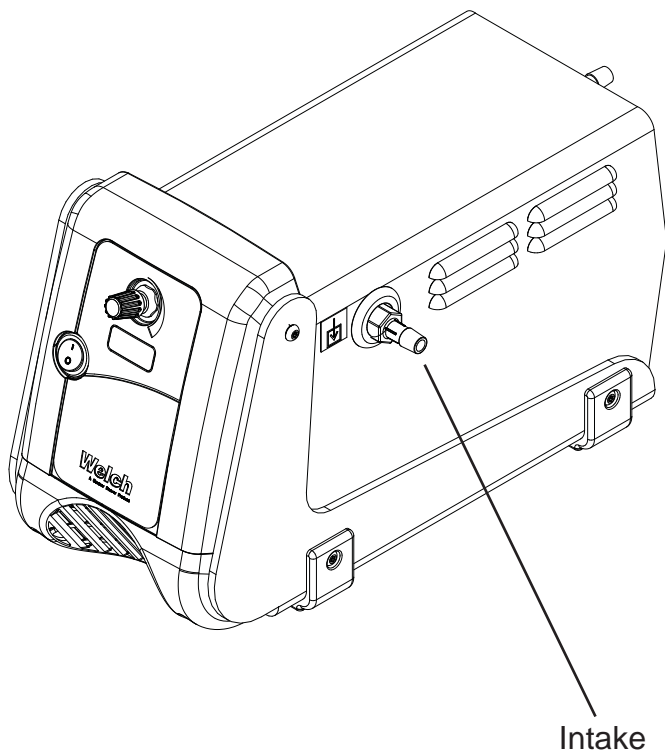

## 2.16 Electrical Power

### 2.16.1 Power Source Review

Review the power source and the motor rating to be sure they agree in voltage, phase and frequency. Serious damage may occur to the motor if it is connected to an improper voltage. All Welch pumps must be grounded. Grounding reduces the risk of electric shock in the event of an electrical short circuit. The plug must be plugged into an outlet properly grounded. Consult your local electrical codes if you have doubts.

Identification Symbols:  Power Off  
| Power On

### 2.17 Advanced Vapor Management (AVM)

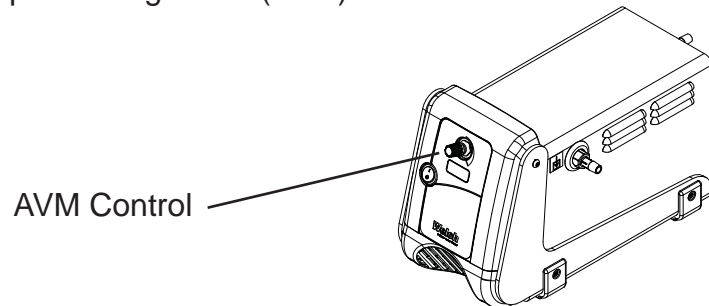

Advanced Vapor Management (AVM) is provided for precise setting of vacuum level.

- Clockwise revolution increases the vacuum level
- Counter- Clockwise revolution decreases the vacuum level

## 2.18 Traps

### 2.181 When to Use a Trap

The use of PTFE or fluorinated plastics for all wetted parts resists chemical attack allowing the pump to handle aggressive solvent, base and acid vapors. A totally oil free diaphragm mechanism removes the need for a lubricating and sealing fluid for pulling a vacuum. When pumping gases or low vapor loads, a trap is not necessary unless you want to capture vapors evolved from the process.

When a heavy load of water or organic vapor is evolved from the vacuum process, condensation of vapor in the pump mechanism may occur. The reason is the pump is compressing the vapor as it passes through the pump. If the vapor is dense enough, the compression will cause condensation of the vapor in the pump mechanism. The valve system in the pump mechanism is designed to pass the small quantity of liquefied vapor formed when pumping heavy vapor loads. The liquid formed will be ejected from the exhaust port. See Section 5 on pump maintenance on suggestions for purging the vacuum pump of condensed liquids prior to shutting it off.

The ejected liquid from the exhaust port can either be collected in a liquid trap attached to the exhaust port or the vapor trapped in a cold trap placed in-line between the pump and the vacuum chamber. A simple, inexpensive liquid trap can be made from a filtering flask. The filtering flask is connected by 3/8"ID hose to the exhaust port by using the loose hose barb provided.



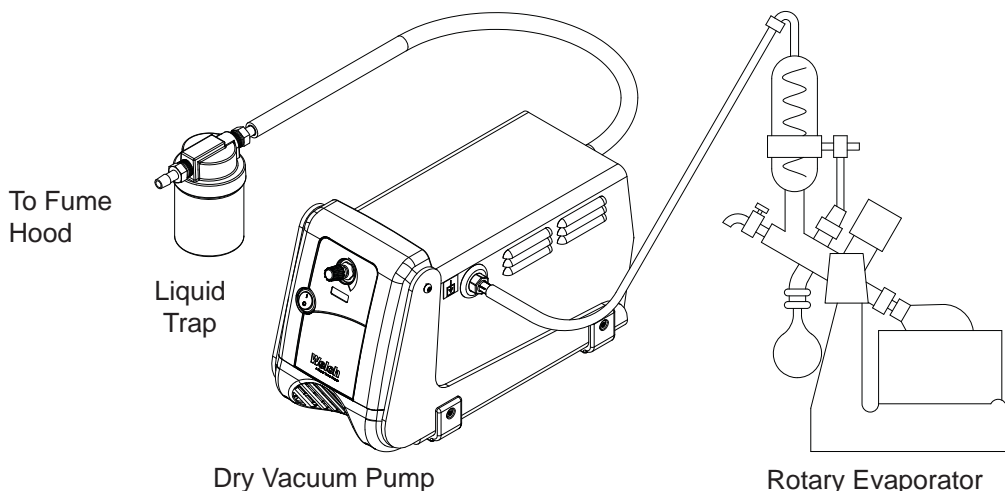

The use of a cold trap when pumping heavy vapor loads will eliminate the need for a liquid trap attached to the exhaust port. The cold trap is installed between the pump and the vacuum chamber. The water or organic vapors evolved from the vacuum process will upon entering the cold trap will come in contact with the surfaces of the trap and condense. Commonly used refrigerants are liquid nitrogen or dry ice with alcohol slurry. Dry ice provides sufficient cooling to freeze out most heavy water vapor loads. A variety of cold traps are available from Welch. Please call our customer service department. For additional information at (847) 676-8800.

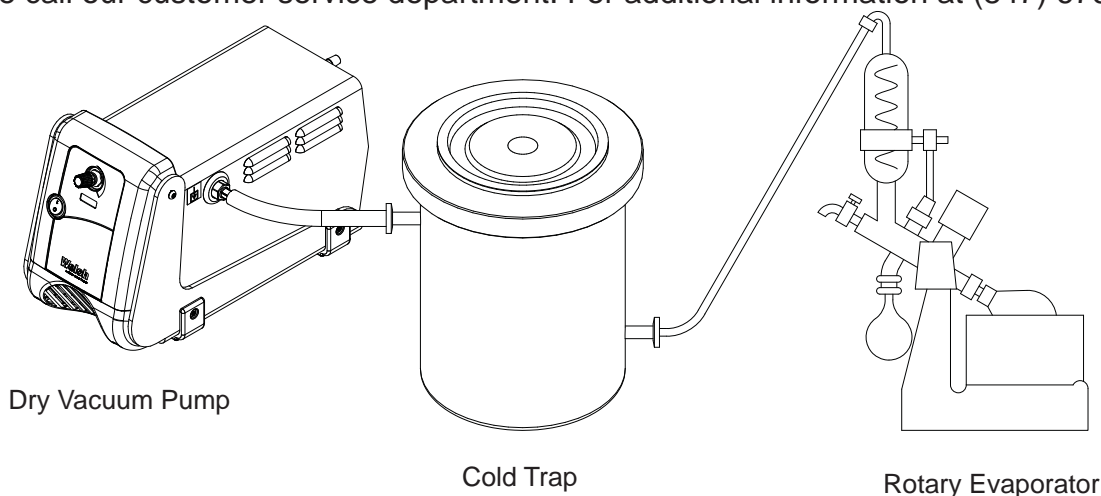

### 2.19 The Care of a Liquid Trap

A liquid trap needs no refrigerant. The key maintenance issue when pumping high vapor loads is to regularly drain the trap of liquid ejected from the dry vacuum pump.

### 2.20 The Care of a Cold Trap

When using a cold trap the refrigerant should be maintained at a high level in the flask to keep the trap at a uniformly low temperature. If the trap is rewarmed it may allow re-evaporation of the condensate. The refrigerant add tube on the liquid nitrogen trap should not be obstructed as the refrigerant boil-off can produce dangerously high pressures. If the trap becomes saturated it should be disconnected from the system, drained and cleaned. An increase in pressure in the vacuum system will normally indicate that the trap has become saturated. To clean the trap, remove the trap from the system and allow the trap to warm up and rinse off the condensate with a suitable solvent in a fume hood. Thoroughly clean and dry the trap before reinstalling into the system. If a liquid nitrogen trap is used, the refrigerant add tube should not be obstructed as the refrigerant boil-off can produce dangerously high pressures.

## Section 3: OPERATION

### 3.10 Starting a Welch Dry Vacuum Pump

Before attaching the pump to a system it is well to familiarize yourself with the function and action of the pressure vacuum pump which you have acquired. Review the power requirements as described in Section 2.6. Welch recommends running the pump for a few minutes to warm it up before use. The warm-up improves the pumps ability to pass water and organic vapor. A warm pump will handle more vapor without liquefying it than a cold pump.

### 3.11 Cleanliness

Take every precaution to prevent foreign particulates or liquid from entering the pump. Particulates will damage the pump's performance. If you find that particulates or liquid will come off during the process of evacuation, a simple liquid trap can be made out of readily available material for protecting the pump. The trap would consist of a filtering flask placed between the pump and the vacuum chamber.

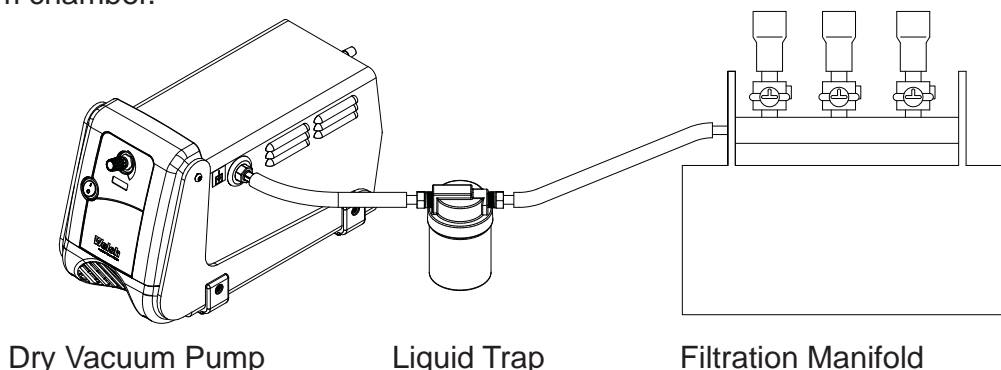

### 3.12 Leak Detection

Eliminating all leaks in a vacuum system is a key to obtaining maximum vacuum. The pump must remove this added volume of leaked gas to maintain the desired vacuum. Leaks can be located by slightly pressuring the system and painting the suspected area with a thick soap solution. Escaping air will produce soap bubbles.

### 3.13 Operating Pressure Range

Vacuum pumps are designed to be run from slightly below atmospheric to their maximum vacuum level on the intake side. Consult the Specification Table in the back of this manual for the ratings for your specific model.

### 3.14 The Effects of Unwanted Vapor

Systems which contain undesirable vapors cause difficulty both from the standpoint of attaining desirable ultimate pressures. A vapor is defined as the gaseous form of any substance which is usually a liquid or a solid. Water, oil, and mercury vapors are three of the more common vapors encountered in typical vacuum systems. When such vapors exist in a system, the vapors or mixtures of gas and vapors are subject to condensation within the pump; the precipitated liquid may thus ultimately solidify on the PTFE heads and diaphragm causing corrosion.

### 3.15 Shutdown Procedures

After use, Welch recommends the pump be run for about 2 minutes disconnected from the vacuum process. The air pumped through the mechanism will purge out water vapor or droplets of condensate that may have formed on the inside of the pump. This purge of the pump mechanism helps prevent build up of solute crystals inside of the pump head. Over time, these crystals will shorten pump lifetime.

## Section 4: MAINTENANCE

### 4.10 General Maintenance

Welch Dryfast Vacuum units are 100% oil-free. The pump employs a diaphragm with an uninterrupted PTFE coating. All bearings are sealed and permanently lubricated. Lubrication should not be attempted. The units are built for duty operation just like a water aspirator, but with the quietness, performance and durability of a diaphragm.

### 4.11 Diaphragm Removal



#### WARNING

Do not remove the diaphragm unless you are wearing hand protection. The steel disc inside the diaphragm may cause harmful injury.

1. Remove the four 4M x 45 screws and washers from the cover plate. Remove the cover plate and head from the plastic head base.
2. Make sure to wear gloves before removing the diaphragm. Grab the diaphragm with both hands and turn counterclockwise to loosen from connecting rod.
3. Remove the diaphragm retaining shims.

### 4.12 Installation of New Diaphragm

1. Apply a minute amount of loctite to threaded diaphragm stud and fasten to connecting rod with shims previously removed.
2. Tighten diaphragm with both hands. Tighten eccentric set screw down on to the flat of the motor shaft.
3. Place the head and chamber assembly on top, rotate fan so that the peripheral lip of the diaphragm aligns with the groove on the underside of the chamber and base plate.
4. Place the cover plate over the head and body using four 4M x 45 screws and washers. Tighten the bolts (no more than 20 inlb.) or PTFE will deform.

## Section 5: APPLICATION

### 5.10 Operation as a Replacement for Aspirators

Models 2014, 2032, 2034, 2037, 2042, 2044 and 2047 are ideal for replacing common water aspirators used for vacuum distillation/extraction filtration, degassing, low pressure source and/or gas transfer. The six basic models are available with free air displacements from 25 to 70 L/min and vacuum to 29.85 inches of Hg. water aspirators have been the researchers' traditional source of rough vacuum to 28.5" Hg (36 Torr) and pumping speed up to 20 L/min. Compare the pump down curves for Models 2037 and 2047 to a standard water aspirator. See the table below to cross reference the correct Welch Dry Vacuum pump with your water aspirator.

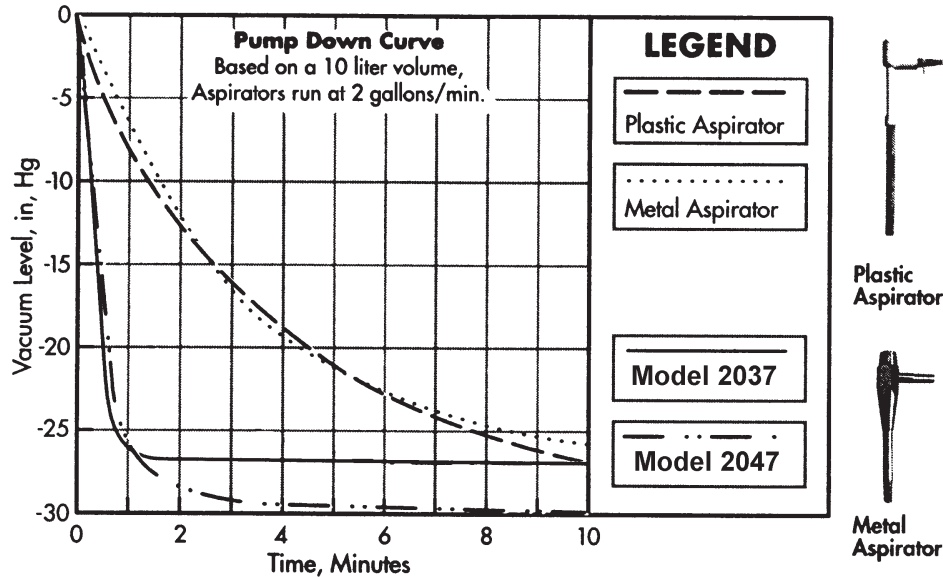

Note: Plastic and Metal Aspirator run at 30 PSIG water pressure.

### 5.20 Cross Reference Welch Dry Vacuum Pump with your Water Aspirator

Style of Aspirator Pump	Water Flow (gal/min)	Water Pressure 1 (PSIG)	Matching Welch Dryfast Pump Catalog Number	Welch Pump Replaces up to:
Plastic or Metal	2	30	2014, 2032, 2042, 2034, 2044 2037 2047	2 Aspirators 3 Aspirators 4 Aspirators

Note:

1. Common water pressure found when using water aspirator. Water pressure drops as more water aspirators are turned on leading to poor vacuum for all.
2. Higher water flow rates and/or higher water pressure will increase the pumping speed and ultimate pressure of a water aspirator.

## Section 6: SPECIFICATION

### 6.10 Specification Table

Welch Model	<b>DRYFAST<sup>®</sup></b>				
	<b>DRYFAST ULTRA<sup>®</sup></b>				
	2032	2042	2034	2044	2037
Free air Displacement CFM (L/min) @ 60Hz CFM (L/min) @ 50Hz	0.9 (25) 0.75 (21)	1.2 (35) 1.0 (29)	0.9 (25) 0.75 (21)	1.2 (35) 1.0 (29)	1.8 (50) 1.5 (42)
	2.5 (70) 2.1 (58)				
Maximum Vacuum in. Hg	29.85	29.85	29.6	29.6	28.5
Ultimate Pressure Torr (mbar)	2 (3)	2 (3)	9 (12)	9 (12)	35 (47)
Maximum Continuous Pressure PSIG (Pascal)	0	0	0	0	0
Tubing needed, I.D., inches	1/4	1/4	1/4	1/4	1/4
Weight, lbs (kg)	21 (9.6)	21 (9.6)	21 (9.6)	21 (9.6)	21 (9.6)
Catalog Number Wired for 115V, 60Hz, 1 Phase with North American 115V Plug	2032B-01	2042B-01	2034B-01	2044B-01	2037B-0
Catalog Number Wired for 230V, 50Hz, 1 Phase with European Schuko Plug	2032C-02	2042C-02	2034C-02	2044C-02	2037C-02
Catalog Number Wired for 100V, 50/60Hz, 1 Phase with North American 115V Plug	2032C-05	2042C-05	2034C-05	2044C-05	2037C-05
Motor H.P.	1/5	1/5	1/5	1/5	1/5
Motor Voltage 50/60Hz 60Hz 50/60Hz	230V 115V 100V	230V 115V 100V	230V 115V 100V	230V 115V 100V	230V 115V 100V
Motor Amps 230V 50Hz (N.L. - F.L.) 115V 60Hz (N.L. - F.L.) 100V 50/60Hz (N.L. - F.L.)	0.4 - 0.6 0.9 - 1.6 0.7-1.3 / 0.8-1.4	0.4 - 0.6 0.9 - 1.6 0.7-1.3 / 0.8-1.4	0.4 - 0.6 0.9 - 1.6 0.7-1.3 / 0.8-1.4	0.4 - 0.6 0.9 - 1.6 0.7-1.3 / 0.8-1.4	0.4 - 0.6 0.9 - 1.6 0.7-1.3 / 0.8-1.4

## Section 7: WARRANTY

### UNPACKING

Inspect the pump carefully. If any damage has occurred, file claim with the carrier immediately. Save the shipping container for carrier to inspect.

### OPERATING PUMP

Refer to the enclosed Instruction/Operation Manual for all information to properly operate and maintain the pump.

### WARRANTY

This Welch Vacuum product is warranted to be free from defects in material and workmanship. The liability of Welch-Ilmvac under this warranty is limited to servicing, adjusting, repairing or replacing any unit or component part which in the judgment of Welch-Ilmvac has not been misused, abused or altered in any way causing impaired performance or rendering it inoperative. No other warranties are expressed or implied. The method of executing this warranty: servicing, adjusting, repairing or replacing shall be at the discretion of Welch-Ilmvac. Vacuum pumps that have been used for any period, however short, will be repaired under this warranty rather than replaced.

The warranty is effective for one year from the date of original purchase when:

1. The warranty card has been completed and returned.
2. The product is returned to the factory or other designated service centers, freight prepaid.
3. The product in our judgment is defective through no action or fault of the user.

If the product has become defective through misuse, abuse, or alteration, repairs will be billed regardless of the age of the product. In this event, an estimate of the repair costs will be submitted and authorization of these charges will be required before the product is repaired and returned.

To obtain a return authorization number, please fill in the on-line request form on [www.welchvacuum.com](http://www.welchvacuum.com). Products without a return authorization number will be refused by our receiving department. Before shipping, properly pack the pump, insure it against loss or damage, and on the outside of the pump packaging and the packing slip write in the return authorization number. Pumps damaged due to improper packaging are the customer's responsibility.

# Section 8: DRAWINGS

## 8.10 Dimensional Drawing

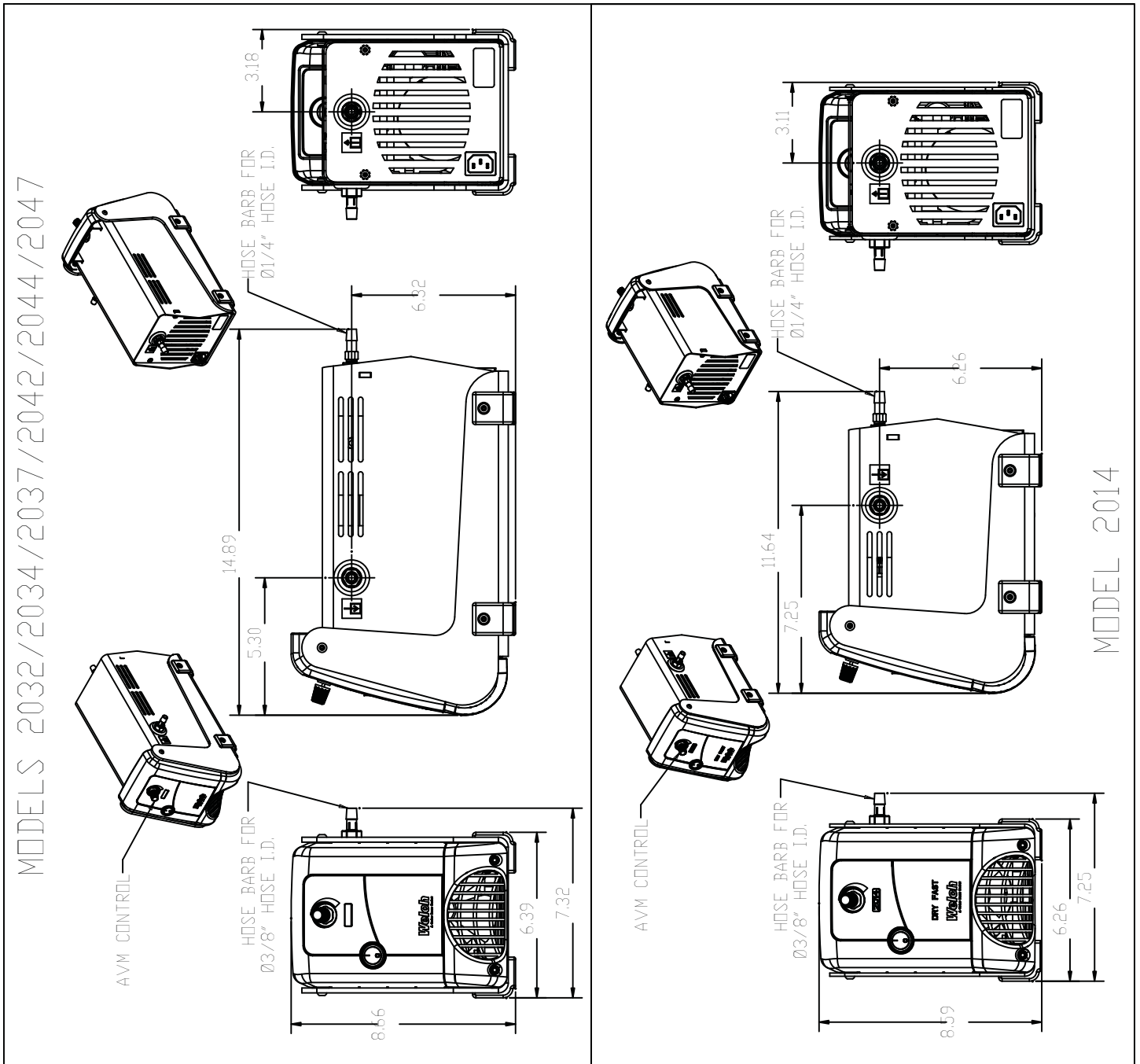

## 8.20 Exploded View and Kit for Model's 2034 , 2037 & 2044

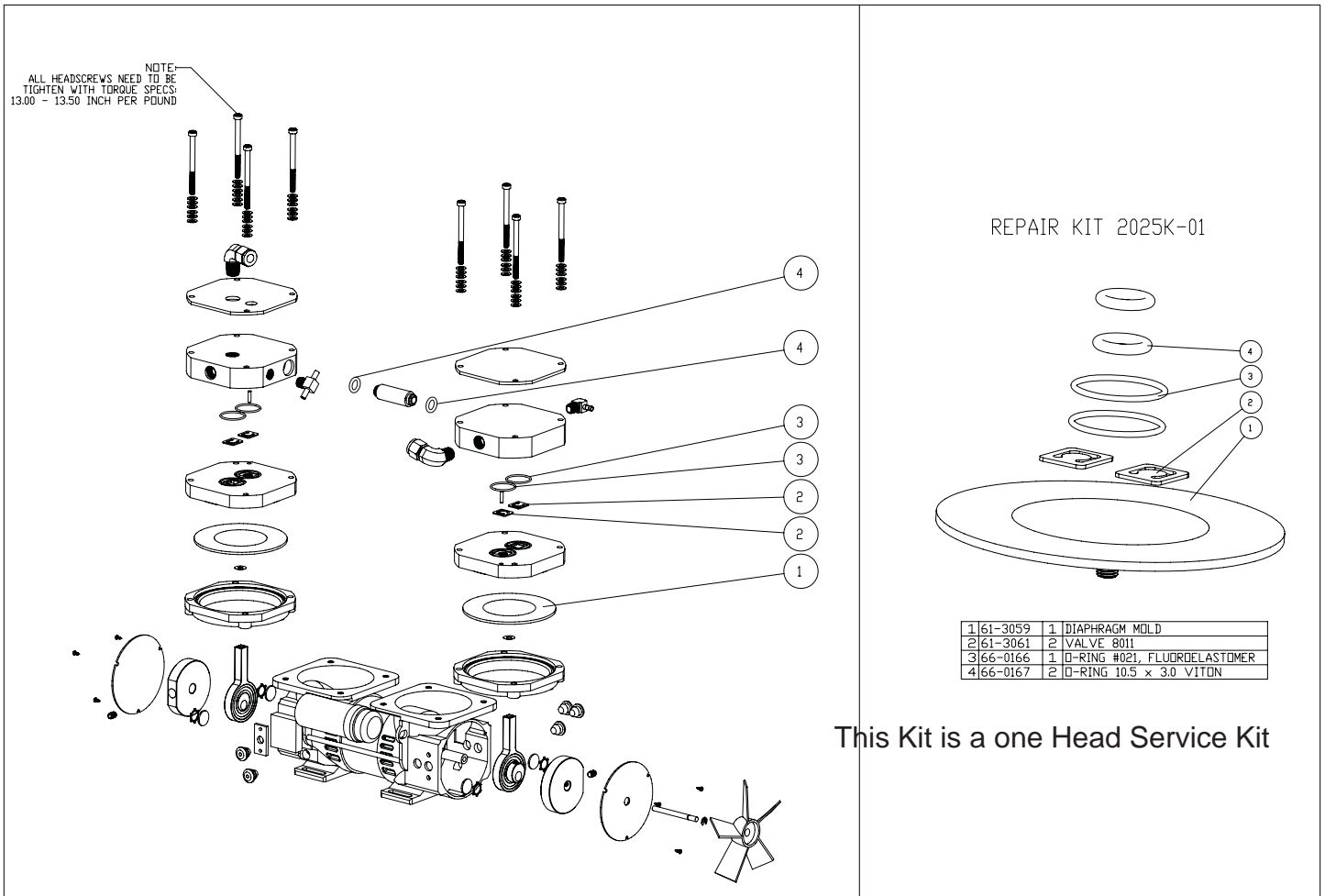



### 8.30 Exploded View and Kit for Model's 2014, 2032, 2042 & 2047

