

Chemtech Scientific provides access to this content as a courtesy.
We do not own the content contained in this document.
All rights and credit go directly to its rightful owners.
www.chemtechsci.com
Call us at: 484-424-9415



OWNER'S MANUAL FOR DUOSEAL® VACUUM PUMPS

MODELS:
1400, 1405, 1402,
1376, 1397, 1374,
1399, 1380, 1392

Installation
Operation
Maintenance
Specification
Dimensional Drawings
Parts List
Accessories
MSDS Sheet for DUOSEAL® OIL



WARNING

Never Block the Exhaust Port.
If the exhaust is blocked, pressure will build-up in the pump
with the potential of the pump body bursting and causing
possible injury to personnel in the area.

Welch Rietschle Thomas
7301 North Central Ave.
Skokie, IL 60077
Phone: (847) 676-8800
Fax: (847) 677-8606 (Technical Support)
Fax: (920) 451-4397 (Ordering)
Web Page: www.welchvacuum.com
E-mail: welchvacuum@thomasind.com

Part No. 67-0777R2.9
Printed in the U.S.A.

CONTENTS

SECTION	PAGE
1. Installation	3-5
2. Operation	6-8
3. Maintenance	9-11
4. Trouble Shooting Guide	12
5. Quick Reference Charts	13-14
6. Pumping Speed Curves	15
7. Dimensional Drawings (with rotation)	16-17
8. Exploded Parts Listings	18-31
9. Accessory Section	32-33
10. MSDS Sheet For DUOSEAL® OIL	34

PLEASE READ BEFORE OPERATION

While reading your manual, please pay close attention to areas labeled **WARNING AND CAUTIONS**.
The description of each is found below.

WARNING
Warnings are given where failure to observe instruction could result in injury or death to people

CAUTION
Cautions are found where failure to observe the instruction should result in damage to the equipment, associated equipment and process.

These units conform to the SI International system of units of measurement.
The following symbols (with recommendations of IEC1010) of warning will be found on the pump.

Caution- refer to accompanying documents



Caution- risk of electrical shock



Caution- hot surface



WARNING
Motor includes a self resetting thermal cutout and the pump could restart without actuation under fault condition.

Section 1: INSTALLATION

1.1 Introduction

This manual has been compiled not only for the care and maintenance of the DUOSEAL pump now in your possession but as a helpful reference and guide for many problems which are usually associated with mechanical vacuum pumps. Take time to read these instructions carefully and preserve this manual for future reference; we think it will be useful to you.

1.2 Unpacking

Carefully remove the pump from the shipping case and unfasten and remove the wooden skid. Preserve all paper work and inspection tags for future reference. If damage has occurred from shipment a claim must be filed with the carrier immediately; preserve the shipping container for inspection by the carrier. If you are required to communicate with your dealer or with Welch Vacuum be sure to include your order numbers for quick identification. Do not return the pump to the factory with out first calling for a returned goods number.

1.3 Pump Mounting

1.3a Mounted Pumps

Rubber bumpers are supplied with most of our mounted pumps, either loosely or attached. Bumpers are excellent for applications involving a semi-flexible surface such as a bench top; they help to isolate noise and eliminate creeping. For more rigid requirements, the pump base may be bolted directly to a firm foundation with or without the bumpers. All DUOSEAL pumps should be mounted in a horizontal plane.

1.3b Unmounted Pumps

If you have purchased an unmounted pump, refer to parts list for information concerning the motor, motor pulley and belt necessary to drive your particular pump at the recommended speed.

1.4 Pump Location

The pump should be located preferably in a clean and well ventilated area and adequate space should be provided wherever possible for routine maintenance such as changes of oil and belt adjustments and replacements. Above all, the pump should be located as closely as possible to its system in order to utilize it most efficiently. Its location should include such determining factors as the length and size of connections, the number of bends and the type of exhaust connections.

1.5 Exhaust Provisions (See Accessory section in back of this manual.)

Exhaust connections will be determined by the type of system to be exhausted and the desired cleanliness of the atmosphere surrounding the pump. Under normal conditions of mild evacuation nothing more than the dust cap will be necessary to cover the port. Where relatively high gas flows are involved or where the presence of oil vapor is objectionable an exhaust filter may be fastened to the exhaust port in place of the dust cap. The exhaust filters used on our pumps are capable of absorbing and restricting any vapor particle larger than 0.1 micron.



WARNING

Never block the exhaust port. If the exhaust port is blocked, pressure will built-up in the pump with the potential of the pump body bursting and causing possible injury to personnel in the area.

Where extreme exhaust conditions are encountered it is best to pipe the exhaust direct out of the building. Welch recommended wire reinforced PVC, metal pipe or thick walled rubber hose be used as exhaust lines to avoid potential of line becoming crimped or collapsing resulting in the exhaust port being clogged. Be sure to call Welch technical service prior to start-up at 847-676-8800 if you have any questions.

1.6 Electrical Power

1.6a Power source Review

Review the power source and the motor rating to be sure they agree in voltage, phase and frequency. On three-phase applications the direction of rotation of the motor must be considered. Make a momentary check rotation at the time of power installation and wiring. Momentary backward rotation of the pump is not harmful. Check the layout drawings for proper direction of rotation.



CAUTION
Make certain the power settings on the pump match your power source before attempting to operate the pump



1.6b Overload Protection

Motor thermal overload protection is made available by the motor manufacturer as an aid to minimizing motor failure. Overload protection is a standard feature on all single-phase 60Hz motors. Single-phase motors will normally have automatic overload protection. Motors of 1-1/2 horsepower or larger supplied with DUOSEAL pumps contain no overload protection. Installations of such equipment must comply with local electrical codes which dictate appropriate starter and protection devices. It is strongly suggested that you familiarize yourself with the protection supplied with your motor so that you may react accordingly in the event of an emergency. Automatic reset protection is designed to reset itself after a predetermined cooling period. If the fault to the drive remains unaltered, the motor will cycle on and off until the fault is corrected. The motor data plate will indicate the presence of thermal protection.

1.7 Vacuum Connections (See Accessory Section in back of this manual.)

1.7a Choice of Connections

The choice of connections and fitting can have a very marked effect on the pumping speed at the vacuum chamber. Any connection placed between the pump and the chamber creates an impedance to the flow of gas. This is particularly true at low pressures in the millitorr range where the gas flow is substantially molecular in character. The gas flow is then dependent upon the kinetic activity of the molecules to bring it to the intake of the pump.

1.7b The Effects of Conductance

It has been shown that the conductance of a tube is proportional to the cube of its radius and inversely proportional to its length. Therefore it is imperative that the connecting lines be as large in diameter and as short in length as practical. For best results the diameter of the connecting tube should be at least as large as the diameter of the pump intake. To avoid a large reduction in pumping speed at the vacuum chamber, it is clear that the conductance of the line must be considerably greater than the speed of the pump.

1.7c Metal Joints

If metal piping or tubing is used, it is preferable to solder or braze all of the connections. Where threaded joints must be used, coat the threads with LocTite® Thread Sealant with Teflon®, or Leak Lock and screw together tightly. Flanged connections with elastomer gaskets make excellent demountable joints. Modular vacuum piping and fittings are now extensively used.

1.7d Rubber Tubing Joints

Where metal tubing is used between the system and the pump intake, joints can be made by butting the ends of the two sections together in a short section of vacuum hose. Worm-screw band clamps are useful for securing the hose to the tubing. Whatever the joint you choose to use, cleanliness should be of utmost importance.

1.7e Valves and Stopcocks

Metal valves or stopcocks may be used in the connecting line between the system and the pump to provide a means of isolating the pump from the system. To minimize the impedance of flow, the valve openings should be as large as possible. Lubricate the rotating plug of the stopcock with a film of vacuum grease sufficiently thick enough to prevent seizure.

1.8 Vacuum Gauges (See Accessory section in the back of this manual.)

The type of vacuum gauge to be used is determined largely by the pressure range to be measured. Pressures in the ranges produced by DUOSEAL pumps can be covered by McLeod, Pirani or Thermocouple gauges. The McLeod gauge is used where high accuracy of measurement is required. The Pirani and Thermocouple gauges are electrical and give continuous readings of the total pressure. They are preferred where rapid pressure changes occur. The McLeod gauge does not measure condensable vapors; therefore, if vapors are present it will generally read lower in pressure than electrical gauges. For higher vacuums in systems employing diffusion, turbo-molecular or ion pumps, a hot or cold cathode gauge is used.

1.9 Traps (See Accessory section in the back of this manual.)

1.9a The need for a Trap

Where corrosive vapors or large quantities of condensable vapors are evolved from vacuum processing, a cold trap may be used in the connecting line to the pump. It will help prevent damage to the pump mechanism and reduce oil contamination. The cold trap, immersed in a suitable Dewar flask, is installed so that the vapors may come in contact with the surfaces of the trap and condense. Commonly used refrigerants are liquid nitrogen or dry ice and acetone. The refrigerant to be used depends upon the freezing point of the contaminations. A variety of cold traps are available from Welch Vacuum, Thomas Industries, inc.

1.9b The care of a Trap

When using a cold trap the refrigerant should be maintained at a high level in the flask to keep the trap at a uniformly low temperature. If the trap is re-warmed it may allow re-evaporation of the condensate. The refrigerant add tube on the liquid nitrogen trap should not be obstructed as the refrigerant boil-off can produce dangerously high pressures. If the trap becomes saturated it should be disconnected from the system, drained and cleaned. An increase in pressure in the vacuum system will normally indicate that the trap has become saturated. To clean the trap, remove the trap from the system, allow the trap to warm up and rinse off the condensate with a suitable solvent in a fume hood. Thoroughly clean and dry the trap before reinstalling in the system.

1.10 Types of Lubricants (See Accessory section in the back of this manual.)

All DUOSEAL mechanical vacuum pumps are normally tested with DUOSEAL® oil and shipped with a full charge to prevent unnecessary contamination. An additional supply of oil is furnished with each pump with instruction to drain and discard the oil contaminated in the pump and replace with the fresh oil. DUOSEAL oil has been especially prepared and is ideally suited for use in mechanical vacuum pumps because of its desirable viscosity, low vapor pressure and chemical stability.

The vacuum guarantee on all DUOSEAL pumps applies only when DUOSEAL oil is used. Other lubricants for special applications are available including various lubricants compatibility, lubricants for use with diffusion pumps as well as other special requirements.

Section 2: OPERATION

2.1 Starting Procedures

2.1a Starting a DUOSEAL Pump

Before attaching the pump to a system it is well to familiarize yourself with the function and action of the pump which you have now required. Remove the intake and exhaust port plugs and temporarily provide a stopper for the intake and a dust cap for the exhaust. Review the power requirements as described in Section 1.6.



CAUTION

Do not run this pump with the intake open directly to the atmosphere. The pump will overheat, excessive oil mist will be emitted from the exhaust and the pump will eventually seize.

2.1b Starting of the Model 1392 with Diffusion Pump.

1. Turn on Mechanical pump ONLY until a pressure of 100 millitorr or less has been reached.



WARNING

Do NOT operate diffusion pump until a pressure of 100 millitorr has been reached. Turning on the diffusion pump before a pressure of 100 millitorr has been reached will damage your diffusion pump and may cause serious damage to surrounding equipment and personnel.

2. After a pressure of 100 millitorr had been reached by the mechanical pump, plug in the diffusion pump. Make sure diffusion pump has oil in it at an appropriate level before turning it on. Check the oil indicator sight glass to confirm oil level. Also, make sure that fan is on when operating diffusion pump. Note that it will take the diffusion pump a few minutes to warm up.

Refer to the Varian diffusion pump manual for more information.

2.1c Cleanliness

Take every precaution to prevent foreign from entering the pump. A fine mesh screen is provided for this purpose in the intake passage of all DUOSEAL pumps.

2.1d Oil Level Determination

The amount of oil suitable for efficient and satisfactory performance should be determined after the pump has reached its operating temperature. Initially, however, the pump should be filled with fresh oil while the pump is idle. Fill the pump until the oil level falls half way of the oil level window. If after a short period of operation the level should fall, it is likely the result of oil entering some of the interior pockets of the pump. If the oil level rises, this signifies oil has drained into the pump cavity while pump was idle. Shut off pump, then drain oil down to proper level.

If a gurgling sound occurs, additional oil must be added. Mechanical pumps will gurgle in varying degrees under four conditions of performance: [a] when operating at high pressure as in the beginning cycles of evacuation of a chamber; [b] when the oil level in the pump reservoir is lower than required; [c] when a large leak is present in the system; and [d] when the gas ballast is open. Awareness of the possibilities will save time in setting up a system. Best performance of a mechanical pump is generally obtained after sufficient time has been allowed for the pump to come to operating temperature.

2.2 Leak Detection

2.2a Large Leaks

The importance of eliminating all leaks in a vacuum system is obvious when it is realized that a leak into the system, at atmospheric pressure, expands in volume by a factor of 750,000 to 10,000,000 or more. The pump must remove this added volume to maintain the desired vacuum. Fortunately a number of effective techniques for leak detection have been developed. Large leaks can be located by pressurizing the system and painting the suspected area with a thick soap solution. Escaping air will produce soap bubbles.

2.2b Small Leaks

Small leaks may also be detected by spraying a suspected area with acetone or gases rich in hydrogen, and observing a sudden change in pressure on an electrical gauge. The difference in calibration of these gauges, for air and other gases, will produce a distinct change in the pressure reading. To use this method of detection, the system must be under vacuum and the gauge sensing tube must be located between the pump and the area to be probed. Use extreme caution, as these materials are highly flammable!

2.2c Fine Leaks

Locating very fine leaks requires a helium-sensitive, mass-spectrometer leak detector. This instrument will locate leaks which cannot be detected by any other method. Numerous fine leaks can have the total effect of a large leak.

2.3 High Pressure Operation

DOUSEAL two-stage pumps are designed to be most efficient when operated at or near their ultimate blankoff pressure. The pump is designed to remove air from a vacuum system at atmospheric pressure to a deep vacuum. When the pump is operated at elevated pressures up to about 10 Torr for long periods of time, the pump will run hotter. At elevated ambient temperatures under these conditions, the thermal protection switch on single phase motors may cut out. Use of an exhaust filter with coalescing element is required.



CAUTION
Do not run this pump for prolonged periods of time at or above 10 Torr. The pump will overheat, excessive oil mist will be emitted from the exhaust and the pump will eventually seize.



Leaky vacuum systems, too large a vacuum chamber for pump size or high gas loads to the vacuum systems are causes for extended runs of the pump at elevated pressure. If you need additional information, please contact Welch Vacuum at 847-676-8800, extension 1, for further information and precautions.

2.4 Shutdown Procedures

2.4a DuoSeal Shutdown

A few simple precautions are all that is necessary when shutdown is in order. If a gauge is connected to the system, first isolate the gauge, then turn off the power and open the system to atmosphere. If the pump is removed from the system, cover the intake port with a rubber stopper or suitable cover to protect the pump against contamination and loose particles. If the pump has been contaminated in service and is going to be shelved for a prolonged period it is best to drain the oil refill with a fresh charge.

2.5 the Principle of Gas Ballast

2.5a the Effects of Unwanted Vapor

systems which contain undesirable vapors cause difficulty both from the standpoint of attaining desirable ultimate pressures as well as contamination of the lubricating medium. A vapor is defined as the gaseous form of any substance which is usually a liquid or a solid. Water, oil and a mercury vapors are three of the more common vapors encountered in typical vacuum systems. When such vapors exist in a system, the vapors or mixtures of gas and vapor are subject to condensation within the pump; the precipitated liquid may thus ultimately dissolve or become emulsified with the lubricating medium. This emulsion is recirculated to the chambers of the pump where it is again volatilized causing increased pressure within the system.

2.5b the Presence and Removal of Condensate

Condensation takes place particularly in the compression stroke of the backing or second stage of a two-stage pump. The compression stroke is that portion of the cycle during which the gas drawn from the intake port is compressed to the pressure necessary to expel it past the exhaust valve. Condensation takes place when the ratio between the initial pressure and the end pressure of the compression is high, that is, when the mixture of vapor and gas drawn from the intake port is compressed from a low pressure to high pressure. By adding air through the gas ballast valve to the mixture of vapor and gas being compressed, the pressure required for delivery past the exhaust valve is reached with a considerably smaller reduction of the volume of the mixture; this, depending upon the amount of air added, condensation of the vapor is either entirely avoided or substantially reduced.

2.5c Pump function With Gas Ballast

In a pump functioning on a contaminated system and operating without the gas ballast, compression within the stage takes place in the normal manner until the saturation pressure of the contaminating vapor contained within the mixture of gas and vapor is reached. The saturation pressure of water vapor is that pressure and corresponding temperature at which the dew point of the vapor is reached and condensation occurs. The saturation pressure of water vapor at an ambient temperature of 20°C is 17.5 Torr, while at 60°C, the approximate operating temperature of a pump, the saturation pressure is 149 Torr. The external side of the exhaust valve is subjected to atmospheric pressure. Consequently a compressive force somewhat greater than atmospheric pressure is required to open the valve and permit expulsion of the gas. Sometime during increased compression of the mixture of gas and vapors, the saturation pressure of 149 Torr for the water vapor is reached and the vapor condenses. The condensate is then allowed to emulsify with the oil which is recirculated within the pump stages thus providing continued contamination of the system.

2.5d Pump function with Gas Ballast

On the other hand, when ballast air at atmospheric pressure is supplied to the compression stroke by means of the gas ballast, the partial pressure of the unwanted vapor becomes a very small part of the total pressure of the mixture of gas, vapor and newly supplied air. The vapor is thus prevented from reaching its saturation pressure corresponding to the temperature of the pump and is finally expelled from the pump as a vapor.

2.5e Controlled Ballast Flow

Some degree of variation in ballast flow may be obtained by the amount of opening applied to the gas ballast. Two or more turns of the gas ballast are sufficient to open it wide. With the gas ballast open, the sound of the exhaust is similar to that of a pump operating against a large leak. Because of the increased pressure introduced into the compression stroke, the pump must work a little harder to function, thus resulting in an increased operating temperature of approximately 8°C over a prolonged period of time. Tests have shown that continuous and prolonged operation for several weeks under these conditions is not injurious to the pump.

2.5f Other Forms of contamination control

The application of the gas ballast is a moderate and very successful method for the removal of condensable vapors. For very heavily laden systems, other means of removal such as oil separators may be required. For mild cases of contamination the simple expedient of a cold trap or a change of oil serve the purpose.

Section 3: MAINTENANCE

3.1 Vacuum Problems

3.1a Pressure Determinations

Leakage, contamination and unusual outgassing are the general causes of problems associated with poor vacuum. To operate at maximum efficiency a system must be thoroughly clean. If the system is completely clean and free from leaks, and unwarranted vacuum problems still exist, the pump should be checked. A simple criterion for the condition of a mechanical pump is a determination of its ultimate pressure capability. This can be accomplished by attaching a gauge directly to the pump. The gauge may be any suitable type provided consideration is given to the limitations of the gauge being used. Refer to Paragraph 1-8 for further suggestions. If the pressure is unusually high, the pump may be badly contaminated, low on oil or malfunctioning. On the other hand, if the pressure is only slightly higher than the guaranteed pressure of the pump, an oil change may be all that is required.

3.1b Oil Contamination

The most common cause of a loss in efficiency in a mechanical pump is contamination of oil. It is caused by condensation of vapors and by foreign particles. The undesirable condensate emulsifies with the oil which is recirculated and subject to re-evaporation during the normal cycle of pump activity this reducing the ultimate vacuum attainable. Some foreign particles and vapors may form a sludge with the oil, impair sealing and lubrication and cause eventual seizure. A gas ballast valve is helpful in removing vapors, especially water, but it is not equally effective on all foreign substances; therefore, periodic oil changes are necessary to maintain efficient operation of the system. The required frequency of changes will vary with the particular system. Experience with the process will help you determine the normal period of operation before an oil change is required.

3.1c Oil Overheating

This pump is designed to operate continuously below 10 Torr. Continuous operation of this pump above 10 Torr will lead to overheating and eventual pump failure. See Section 2.3. High Pressure Operation.

3.2 Maintenance of the Model 1392 with Diffusion Pump

3.2a Determination of an Oil Change

The Model 1400 pump of the diffusion-mechanical pump combination may be repaired and maintained as outlined in the preceding paragraphs. The pump fluid of the diffusion pump should be inspected periodically for color change and odor. If the fluid is slightly darkened and has no odor, a simple change of fluid is normally all that is needed. If the fluid has developed a noticeable odor, the pump should be cleaned. Follow the instructions in the Owner's Manual for the Diffusion Pump.

3.2b Diffusion Pump Cleaning Procedures

To clean the diffusion pump, first turn off the power. Turn off the cooling fan and disconnect the power plug after the diffusion pump has cooled. Disconnect the inlet and foreline connections. Do not scratch or damage sealing surfaces. Remove the cold cap and jet assembly and all O-rings and gaskets. Drain oil from the diffusion pump. Thoroughly clean the diffusion pump body interior and the jet assembly with acetone followed by an isopropyl alcohol rinse. The inside of the pump can be dried using dry nitrogen. Install jet assembly with the cold cap inside of the pump body. Fill the pump with 30ml of fresh diffusion pump fluid. Reinstall the pump in the system. For more detailed information and how to replace a burned heater read instructions on the AX-65 Diffusion Pump Instruction Manual supplied with this pump.



WARNING

Solvents, such as acetone, used to clean different pumps are extremely hazardous. Inhalation may be fatal or harmful. Acetone is also extremely flammable. Never use acetone near heat or open flame. Use only in a well ventilated area.

3.3 Oil Changes and Oil Level

3.3a Developing a Maintenance Schedule

After studying many examples of pump failure, Welch has found the most common reason is poor condition of the oil. This is why a regular maintenance schedule for the oil is critical to obtain the longest service life out of your DUOSEAL pump. Welch recommends that you examine the condition of the oil on a daily basis in the early days of a new process or experiment. You want to look for discoloration of the oil and whether the oil level is rising. The discoloration can indicate deterioration of the oil and a rising oil level can indicate condensation of vapors is occurring in the pump. When changes occur, the oil needs to be change. If no changes in the oil level or color are observed, extended pump service life is obtained if the oil is changed every three to four months.

3.3b Forced Oil Flushing

When you drain oil through the drain valve, you are not removing the oil and contaminants that are inside the pumping mechanism. You are removing oil only from the oil case. Welch recommends a forced oil flush of DUOSEAL pumps be performed at the regular maintenance oil change. The procedure for the forced oil flush is given below.

1. Check the oil level.

If the oil level is well above the fill mark, (This may indicate either the pump has been overfilled with oil or has ingested a liquid or a large amount of vapor water or organic solvents.) Please go to step 2.

If the oil level is even with the fill mark and you do **NOT** suspect corrosive gases or particulates (hence forth called **contaminants**) ingested have damaged the mechanism, run the pump for 15 minutes to allow the pump oil to warm up before going to step 2.

2. Turn off motor for the vacuum pump. Drain the oil into a clear plastic container (may need pliers to open drain valve). Look for contaminations settling to the bottom of container. If you see contaminants, you will need to repeat step 3 through 5 several times until the oil comes out clear. The oil you drained from the pump came from the oil case only. There may be contaminants in the pumping mechanism. To be sure all contaminants have been removed, the pump mechanism needs to be flushed.

3. Make sure the belt guard is installed before proceeding further. Attach a short hose to the drain valve which runs into a clear plastic container.

4. Flushing the pump is carried out by adding a cup of DUOSEAL vacuum pump oil through the intake port (IN) while the pump is turned on for 15 to 20 seconds. While adding the pump oil, the palm of your hand is placed lightly over the exhaust port (OUT). Look for water coming out of the drain. Turn off the pump.

5. Repeat step 4 until clean oil comes out of the drain hose.

6. Fill the pump with the amount of DUOSEAL vacuum pump oil your pump needs.

7. Plug the intake (IN) port with a rubber stopper. Turn the pump on and run the pump for 10 minutes. Close the gas ballast.

8. Check the vacuum reading of the pump by connecting a thermocouple gauge tube to the pump's intake. If the pump is running nearly as good as when it was new, the total pressure reading you will read on wither of these two gauges will be at least 10 micron.

A simple way to connect the gauge tube to the pump is to run the threaded tip of tube through a hole in a rubber stopper. Use pump oil as a lubricant for inserting the tube. The stopper chosen should be bigger than the outer diameter of the intake flange.

3.3c Refilling The Pump

After you are satisfied that the pump has been thoroughly flushed, refill the pump by pouring new DUOSEAL oil into the exhaust port. Fill to the indicated level and start the pump with the intake closed. A gurgling noise is characteristic when high pressure air is drawn through the pump. It should disappear quickly as the pressure within the pump is reduced. If gurgling continues, add sufficient additional oil through the exhaust port until gurgling ceases.

3.4 Shaft Seal Replacement

To replace the shaft seal of a pump, drain the oil and remove the pump pulley and key. Remove the screws securing the old seal and pry it loose with a screwdriver or similar wedge, being careful not to mar the surface of the pump body against which the seal fits. Discard the seal and its gasket, inspect all surfaces and repair any damages with a fine abrasive stone. Wipe all sealing areas clean and place a film of DUOSEAL oil on both the shaft and the inside bore of the new shaft seal. Using a new gasket, carefully slide the new seal into position and center it on the shaft. It is not necessary to apply any sealant to the gasket. Tighten the mounting screws uniformly and refill the pump with DUOSEAL oil. Follow instructions included in repair kit.

3.5 Repairing Vacuum Leaks

3.5a Location, Cause and Effect

Oil leaks may develop wherever two mating faces are sealed with a gasket. Such seams may fail as the result of deterioration of the gasket material, loosening of the screws caused by temperature variations, or improper care as the result of previous reassembly. Typical gaskets seams in a mechanical pump are located at the oil level window, the shaft seal, the oil drain, and the mating faces of such mechanical surfaces as the intake chamber cover, the oil case, and the exhaust chamber cover. The importance of a gasketed seam is determined principally by its function. If it is a vacuum seal, the ultimate performance of the pump is dependent upon it. If it is an oil seal, the pump may be operated satisfactorily for some time without loss of function. Eventually, of course, a great loss of oil may cause harmful damage.

3.5b Repairing Techniques

An oil seam may be sealed by any of several methods. When an O-ring is employed, the surfaces of the O-ring and its groove should be wiped clean. If the O-ring is not badly deformed or scratched it may be reused by sealing with a slight film of vacuum oil or vacuum grease. Thin composition gaskets are generally used for large irregularly shaped areas. A replacement joint of this type should be thoroughly cleaned of all previous gasket material and the mating surfaces cleaned of any nicks.

3.6 Repairing Vacuum Leaks

3.6a Surface Preparation

Good Vacuum seals are an essential and important attribute of a good mechanical pump. A good seal is dependent upon the quality of the mating surfaces as well as the sealant and its preparation. The mating faces should be carefully inspected for any projections or foreign particles which might interfere with proper mating. Slight projections such as nicks and burrs are most easily removed by rubbing with a fine abrasive stone. The surface of the mating parts may be washed with a solvent or alcohol after which they must be thoroughly dried.

3.6b Temporary Repair

Temporary vacuum repairs are often made by covering the known leak with an industrial sealant such as Loctite with Teflon. Such a practice, however, is not recommended for seals of a permanent nature.

3.7 Drive Problems

If for any reason the pump will not operate, turn off the power and check the fuse and electrical connections. Then try the power to the motor only by removing the belt. If the motor operates properly try hand-rotating the pump in the proper direction with the pump intake port open. If both turn freely then replace the belt and check the belt tension. The tension should be sufficient to drive the pump without visible slippage. Any greater tension will cause noise and possible damage to the bearings of both the motor and pump. Make certain that both pulley grooves are clean and free from oil. The pulleys must be fastened securely on their respective shafts, and in parallel alignment.

Section 4: TROUBLE-SHOOTING GUIDE

4.1 Poor Vacuum Reading

1. Disconnect vacuum pump from your vacuum system.
2. Obtain 1 gallon of DUOSEAL oil, 1 gallon or larger clear plastic container, clear drain hose (1/4 inch ID by at least 2.5 feet long), rubber gloves, goggles, apron and pliers.
3. Carry out a forced oil flush (See Section 3.3b) if motor can turn pumping mechanism without excessive noise. If pumping mechanism cannot be turned by motor, have pump sent into factory repair center.
4. Check ultimate vacuum with thermocouple gauge. If reading is still unsatisfactory, consult with Welch Technical Service after checking for leaks in your connections.

4.2 Noisy Pump

1. Locate noise source on your vacuum pump (motor, belt, pump).
2. If motor makes noise:
 - . Check for loose bolts on motor mount.
 - . Motor may need to be replaced
3. If belt makes noise:
 - . Pulley may be bent. If so, replace.
 - . Loose belt, tighten by loosening bolts on motor and moving motor away from pump until belt exhibits a 1/2 inch deflection.
4. If pump makes noise: vanes may be sticking, carry out a forced oil flush.
5. If noise level is still unsatisfactory, consult with WELCH Technical Service at (847)676-8800, Extension 1.

4.3 Excessive Oil Mist

1. Check oil level. Maintain the level between the two lines on the oil window during operation. Too high a level will cause excess oil mist.
2. Determine the vacuum level in your system with a thermocouple gauge or manometer. **Be sure** the pump is operating at a pressure of 10 Torr or lower for continuous operation.

CAUTION: if not, discuss application with Welch Technical service before proceeding to prevent oil from overheating and breaking down resulting in the pump failing.

3. A system leak(s) or degassing can cause excessive oil mist. Locate and seal the vacuum leaks. High vapor loads may require a larger pump to compensate.
4. An oil eliminator can be installed for coalescing the oil mist from the exhaust gases. If an oil mist eliminator is already installed, the element may need to be replaced if saturated with oil. Open up oil mist eliminator and examine the element; replace if needed.
5. Check the oil condition for any visible change in color or consistency. Contaminants in the oil can add to the amount of oil exhausted. Carry out a forced oil flush if contamination is discovered. (See Section 3.3b.)

Section 5: QUICK REFERENCE CHART

Motor Options	1400	1405	1402	1376	1397	1374	1399	1380
Wired for 115V, 60Hz, 1Ph	1400B-01	1405B-01	1402B-01	1376B-01	1397B-01	1374B-01	1399B-01	1380B-01
Wired for 230V, 60Hz, 1Ph	1400C-01	1405C-01	1402C-01	N/A	N/A	N/A	N/A	N/A
Wired for 230V, 50Hz, 1Ph	1400C-02*	1405C-02*	1402C-02*	1376C-03*	1397C-03	1374C-02*	1399C-02	N/A
Wired for 230V, 60Hz, 3Ph	N/A	N/A	1402M-01	1376M-01	1397M-01	1374M-01	N/A	N/A
Wired for 230V, 50Hz, 3Ph	N/A	N/A	N/A	N/A	N/A	N/A	N/A	N/A
Replacement Parts								
Shaft Seal: Lip Seal	1401E-01	1401E-01	1401D-01	1401D-01	1401F-01	1401F-01	1401E-01	1401D-01
Shaft Seal: Mechanical Seal	1401E	1401E	1401D	1401D	1401F	1401F	1401E	1401D
Dust Cap	41-1345	41-1345	41-0612	41-0612	41-1501	41-1501	41-1345	41-0612
Air Filter Screen	41-0890	41-0891	41-0660	41-1692	41-0937	41-0937	41-0306	41-0660
Intake Chamber Cover Gasket	41-0383	41-1308	41-0234	41-0234	41-1495	41-1495	41-2375	41-0234
Oil Case Gasket	41-1052	N/A	41-0403	41-0403	41-1496	41-1496	41-1052	41-0403
Drain Plug	61-2278	61-2278	61-2278	61-2278	61-2278	61-2278	61-2278	61-2278
Oil Window	41-3753	41-3753	41-3753	41-3753	41-3753	41-3753	41-3753	41-3753
Large Vane	41-1059	41-1294	41-0959	41-1684	41-1477	41-1477	41-1059	41-0959
Small Vane	41-1059	41-1294	41-1487	41-1487	41-1487	41-1487	N/A	N/A
Large Vane Spring	41-1304	41-1304	41-1304	41-1304	41-1488	41-1488	41-1304	41-1304
Small Vane Spring	41-1304	41-1304	41-1304	41-1304	41-1304	41-1304	N/A	N/A
Large Vane Spring Holder	41-1063	41-1303	41-1685	41-0696	41-1489	41-1489	41-1063	41-1685
Small Vane Spring Holder	41-1063	41-1303	41-0696	41-0696	41-0696	41-0696	N/A	N/A
Shaft	41-1060	41-1293	41-2093	41-1683	41-1484	41-1484	41-2374	41-1773
Upper Exhaust Valve	41-1239	41-1239	41-2153	41-2153	41-2161	41-2161	41-1239	41-0695
Lower Exhaust Valve	N/A	N/A	41-2154	41-2154	N/A	N/A	N/A	41-1775
Pressure Release Valve	N/A	N/A	41-0992	41-0992	41-0992	41-0992	N/A	N/A
Repair Kits								
Minor Repair Kit	1400K-03	1405K-05	1402K-05	1376K-05	1397K-07	1397K-07	1399K-03	1380K-04
Major Repair Kit	1400K-04	1405K-06	1402K-06	1376K-06	1397K-08	1397K-08	1399K-04	1380K-03
Base and Belt Guard Kit	1371E	1371A-01	1371A-01	1371B-01	1371F	1371F	1371E	1371A-01

	1400B-01	1405B-01	1402B-01	1376B-01	1397B-01	1374B-01	1399B-01	1380B-01	1392B-01	1392B-01
Free Air Displacement, L/M (CFM)	25 (0.9)	91 (3.2)	160 (5.6)	300 (10.6)	500 (17.7)	650 (23)	35 (1.2)	160 (5.6)	25 (0.9)	30L/Sec.
Gas Ballast	Yes	Yes	Yes	Yes	Yes	Yes	No	Yes	No	-
Ultimate Pressure, Torr (mbar)	1 (1.3)x10-4	1 (1.3)x10-4	1 (1.3)x10-4	1 (1.3)x10-4	1 (1.3)x10-4	1 (1.3)x10-4	15 (20)x10-4	5 (20)x10-4	1 (1.3)x10-4	<5 (6.5)x10-8
Rotational Pump (RPM)	580	525	525	525	400	510	750	525	580	-
Oil Capacity, quarts (Liters)	0.62 (0.59)	2.25 (2.1)	2.25 (2.1)	2.5 (2.4)	1.25 (1.2)	1.25 (1.2)	0.5 (0.47)	3.7 (3.5)	0.62 (0.59)	30ml
Net Wt. Unmounted Pump, lb (Kg)	33 (15)	82 (37)	82 (37)	107 (52)	138 (63)	138 (63)	28 (13)	57 (26)	33 (15)	8 (3.6)
Net Wt. Mounted Pump, lb (Kg)	58 (26)	112 (51)	112 (51)	156 (71)	206 (93)	218 (100)	49 (22)	91 (41)	71 (32)	-
Optional Exhaust Filter	1417	1417P-10	1417P-10	1417P-10	1417P-20	1417P-20	1417	1417P-10	1417	-
Optional Exhaust Filter Element	1417L	1417G	1417G	1417G	1417H-01	1417H-01	1417L	1417G	1417L	-
Pump Pulley	41-2191	41-2194	41-2074	41-2074	41-1492	41-1492	41-2191	41-2074	41-2191	-
Standard Belt	1400A	1405A	1405A	1405A	1397A	1374A	1399A	1405A	1400A	-
Standard Hose Barb Fitting	1393J	1393J	1393K	1393K	1393L	1393L	1393J	1393K	N/A	-
Tubing Needed (I.D. Inches)	7/16	7/16	13/16	13/16	1 5/8	1 5/8	7/16	13/16	N/A	-
Standard Flange Adapter Fitting	1393F	1393F	1393G	1393G	1393H	1393H	1393F	1393G	N/A	-
Standard Flange Size	NW16	NW16	NW25	NW25	NW40	NW40	NW16	NW25	NW16	NW50
Intake Thread Size	3/4-20	1-20	1-20	1-20	1 3/4-20	1 3/4-20	3/4-20	1-20	3/4-20	-
Exhaust Thread Size	3/4-20	1-20	1-20	1-20	1 3/4-20	1 3/4-20	3/4-20	1-20	3/4-20	NW16
Electrical Requirements 1	115V	115V/230V	115V/230V	115V/230V	115V/230V	115V/230V	115V	115V	115V	115V
Electrical Requirements 2	60Hz	60Hz	60Hz	60Hz	60Hz	60Hz	60Hz	60Hz	60Hz	60Hz
Electrical Requirements 3	1 Phase	1 Phase	1 Phase	1 Phase	1 Phase	1 Phase	1 Phase	1 Phase	1 Phase	1 Phase

Section 6: PUMPING SPEED CURVES

HIGH EFFICIENCY PUMPING CHARACTERISTIC OF DUOSEAL® PUMPS

The low RPM design of DuoSeal vacuum pumps makes it possible to maintain high pumping efficiencies into the low micron range. High RPM direct drive vacuum pumps, on the other hand, experience a rapid fall off of pumping speed below 100 microns.

A comparison of the DuoSeal pumping speed curves shown below, versus high RPM pump speed curves conclusively illustrates the superior performance of the DuoSeal pump.

What does that mean for the vacuum pump user?
DuoSeal pumps provide considerable faster pumpdown in the low micron range.

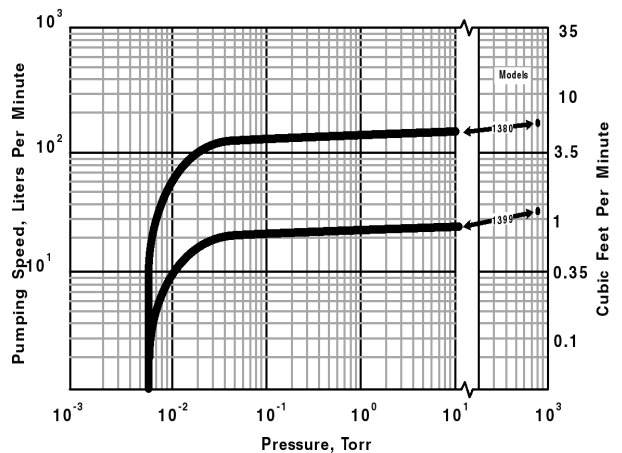
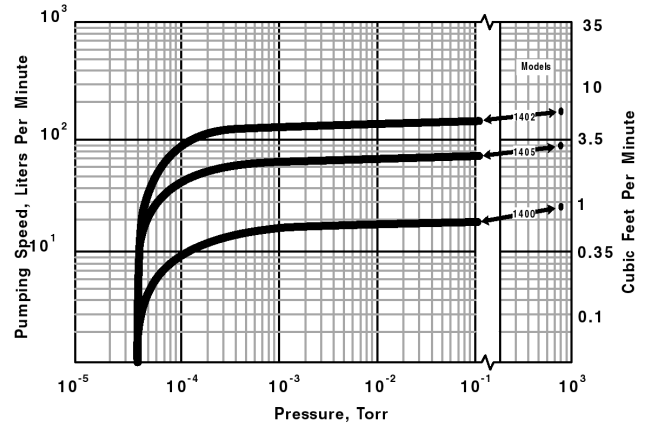
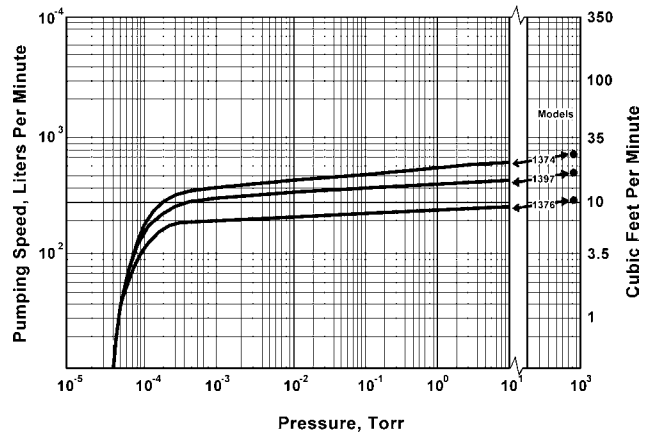

Section 7: DIMENSIONAL DRAWINGS

Mounted Pumps

1374B-01

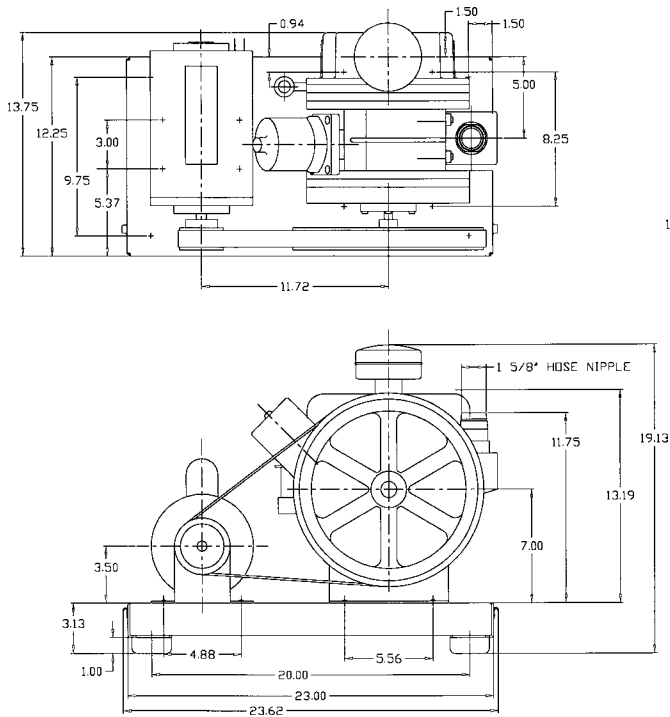

1376B-01

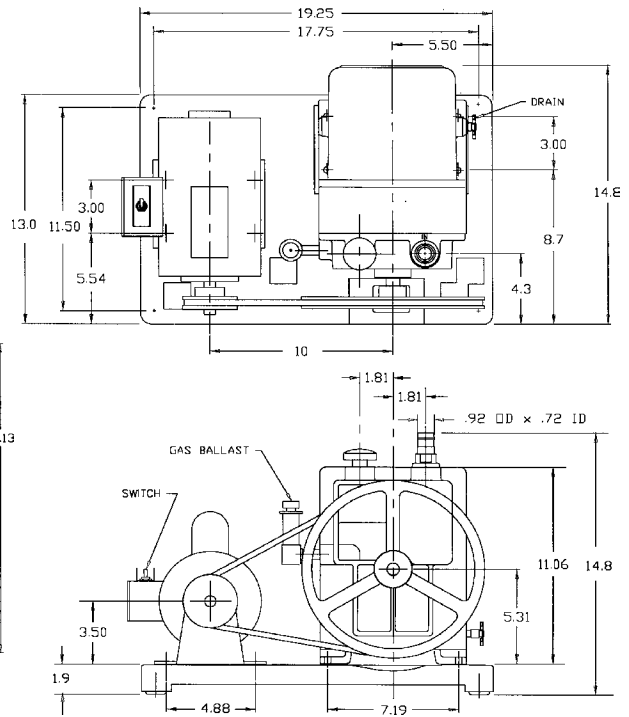

1380B-01

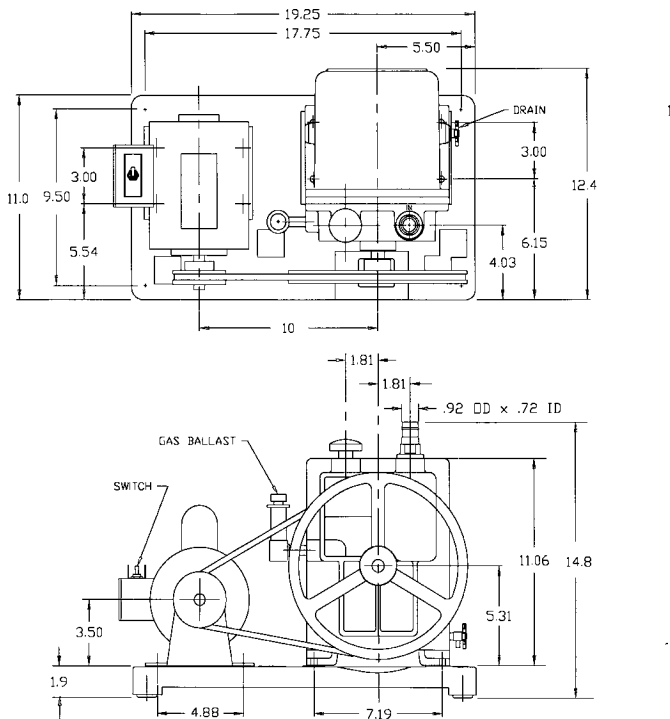

1392B-01

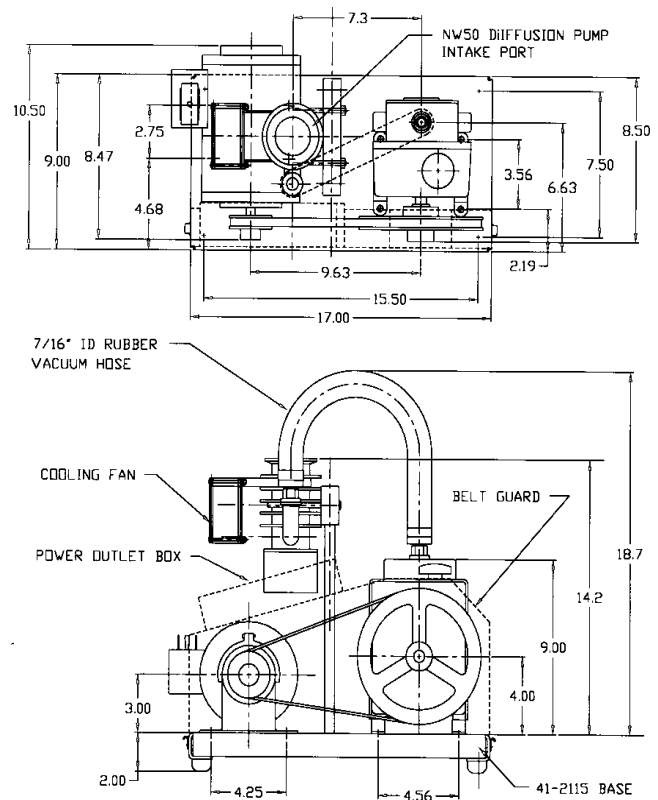

1397B-01

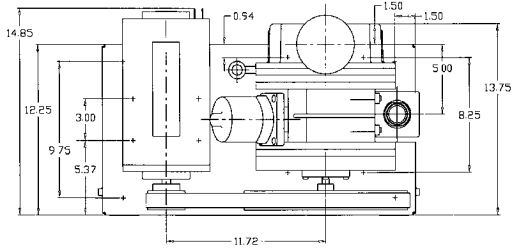

1399B-01

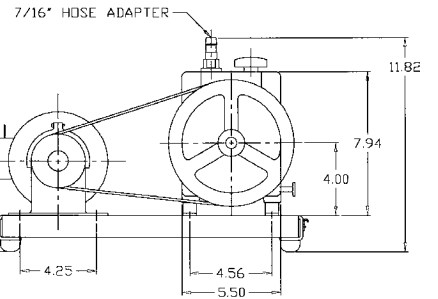
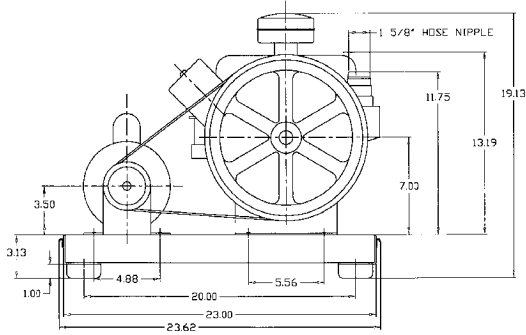
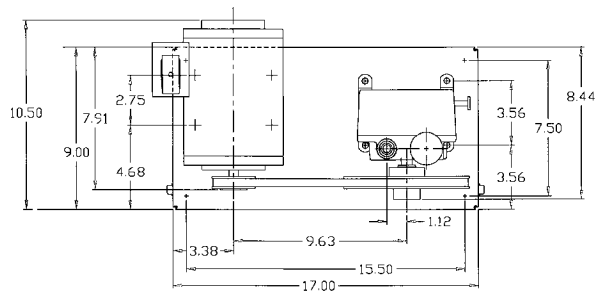

1400B-01

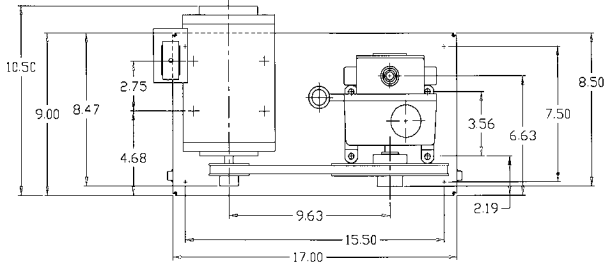

1402B-01

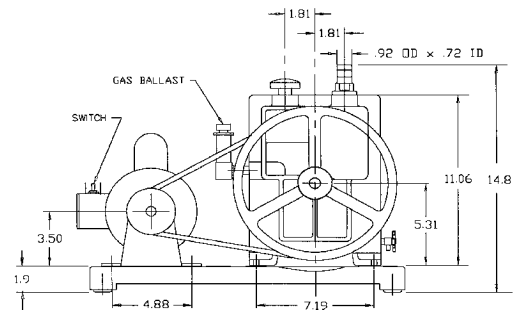
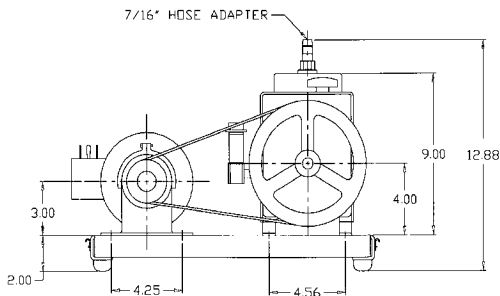
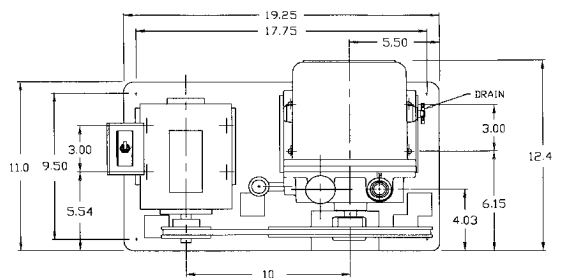

1405B-01

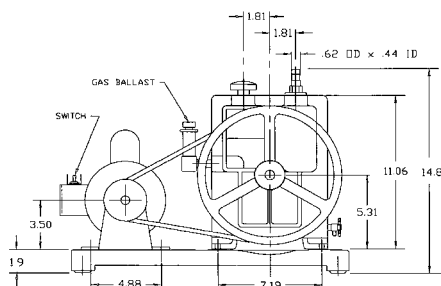
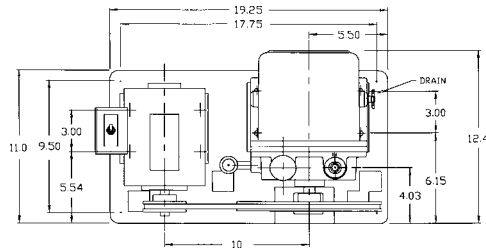

Section 8: PARTS LISTS & EXPLODED VIEWS

PARTS LIST MODEL 1376 VACUUM PUMP

ITEM	QUAN	PC. NO.	A*	B*	DESCRIPTION	ITEM	QUAN	PC. NO.	A*	B*	DESCRIPTION
01	1	41-2074			Pulley incl. item 2	38	1	41-0992	1	1	Pressure Release Valve
02	1	2-01-9306			Socket Head Set Screw 5/16-18x3/8	39	1	61-8309B			Pressure Release Tube Part 1
03	1	61-8378A			Shaft Lip Seal Assy	40	3	62-0259			Self Tap Screw #6x1/4 Type 'A'
04	1	41-0643			Seal Gasket	41	6	2-01-0356			Hex Head Screw 5/16-18x3-1/2
05	3	2-00-2706			Fil. Head Screw 10-32x3/8	42	1	41-2154	1	1	Lower Exhaust Valve
06	1	61-8685			Large End Plate	43	7	2-61-0000			Steel Washer 1/4
07	1	61-8671			Intake Cover	44	2	2-01-8128			Set Screw 1/4-20x1-3/4
08	1	41-0234	1	1	Intake Cover Gasket	45	6	2-31-0112			Hex Nut 1/4-20x3/16x7/16
09	4	2-01-6112			Socket Head Screw 1/4-20x3/4	46	4	61-8314A	4	4	Block Valve
10	1	41-1692	1	1	Intake Screen	47	4	41-2158	4	4	Valve Spring
11	1	61-8329A			Intake Screen Bracket	48	2	41-2156			Valve Block
12	6	41-2363			Washer	49	2	41-2159	2	2	Valve Block Spacer
13	3	2-01-6316			Socket Head Screw 5/16-18x1	50	1	61-8102A			Flange for Gas Ballast Valve
14	1	41-0612			Dust Cap	51	3	2-00-6712			Socket Head Screw 10-32x3/4
15	1	61-8468A			Adapter Hose	52	1	41-1686			Baffle Plate
16	1	61-9284A	1	1	O-Ring, Fluoroelast. #214	53	2	41-2175			Set Screw (Special)
17	2	41-0403	2	2	Oil Case Gasket	54	1	61-8687			Oil Case Spacer
18	10	62-0015			Socket Head Screw 1/4-20x3-1/8	55	1	61-8101			Oil Case Assy incl.items 63,67,72,74,75
19	1	41-0508	1	1	Thrust Washer	56	2	61-8362			Socket Head Screw 8-32x1
20	1	41-1683			Shaft	57	1	61-8100A			Gas Ballast Valve Adapter
21	1	41-0624	1	1	Pulley Key	58	1	61-8103	1	1	O-Ring, Fluoroelast. #905-75
22	1	41-1688			Large Ring	59	1	41-1736			Gas Ballast Valve incl. item 64
23	1	41-1682			Large Rotor	60	6	61-8456A			Washer Copper 5/16
24	2	41-1684	2		Large Vane	61	2	41-1056			Washer
25	3	41-0696	3	3	Spring Holder	62	10	2-63-0193			Split Lock Washer 1/4
26	6	41-1304	6	6	Vane Spring	63	2	61-2229A			Glass Window
27	1	61-8250C			Center Plate	64	1	41-1742	1	1	O-Ring, Fluoroelast. #011
28	2	2-36-9900			Lock Nut 1/4-20	65	3	41-1766			Thrust Disk
29	2	2-01-6320			Socket Head Screw 5/16-18x1-1/4	66	1	61-8101A			Gas Ballast Connector
30	1	41-1518			Exhaust Rotor	67	1	61-2278			Drain Valve
31	2	41-1487	2		Small Vane	68	1	41-2757			Lock Nut
32	2	41-0613	2	2	Woodruff Key	70	1	2-01-5106			Round Head Screw 1/4-20x3/8
33	1	61-8108D			Exhaust Ring	71	1	41-2153	1	1	Upper Exhaust Valve
34	1	41-2045			Small End Plate	72	2	61-2370			Cover, Window
35	1	41-0672			End Cap	73	3	2-01-0316			Hex Head Screw 5/16-18x1
36	1	61-8310A			Pressure Release Tube Part 2	74	2	61-2231	2	2	O-Ring, Fluoroelast. #127
37	1	4-40-1200	1	1	Steel Ball	75	4	62-1037			Flat Hd Screw 8-32x7/16
								1-99-5282	1	1	Sealant, 6 cc
								1401D	1	1	Mechanical Seal option**

A*: MAJOR REPAIR KIT CAT # 1376K-06

B*: MINOR REPAIR KIT CAT # 1376K-05

** 1401D is mechanical seal kit includes mechanical seal, gasket and 3 screws

*** MANOR REPAIR KIT CAT # 1376K-11 FOR REFRIGERATION SERVICE PUMPS

USES NEOPRENE SEALS

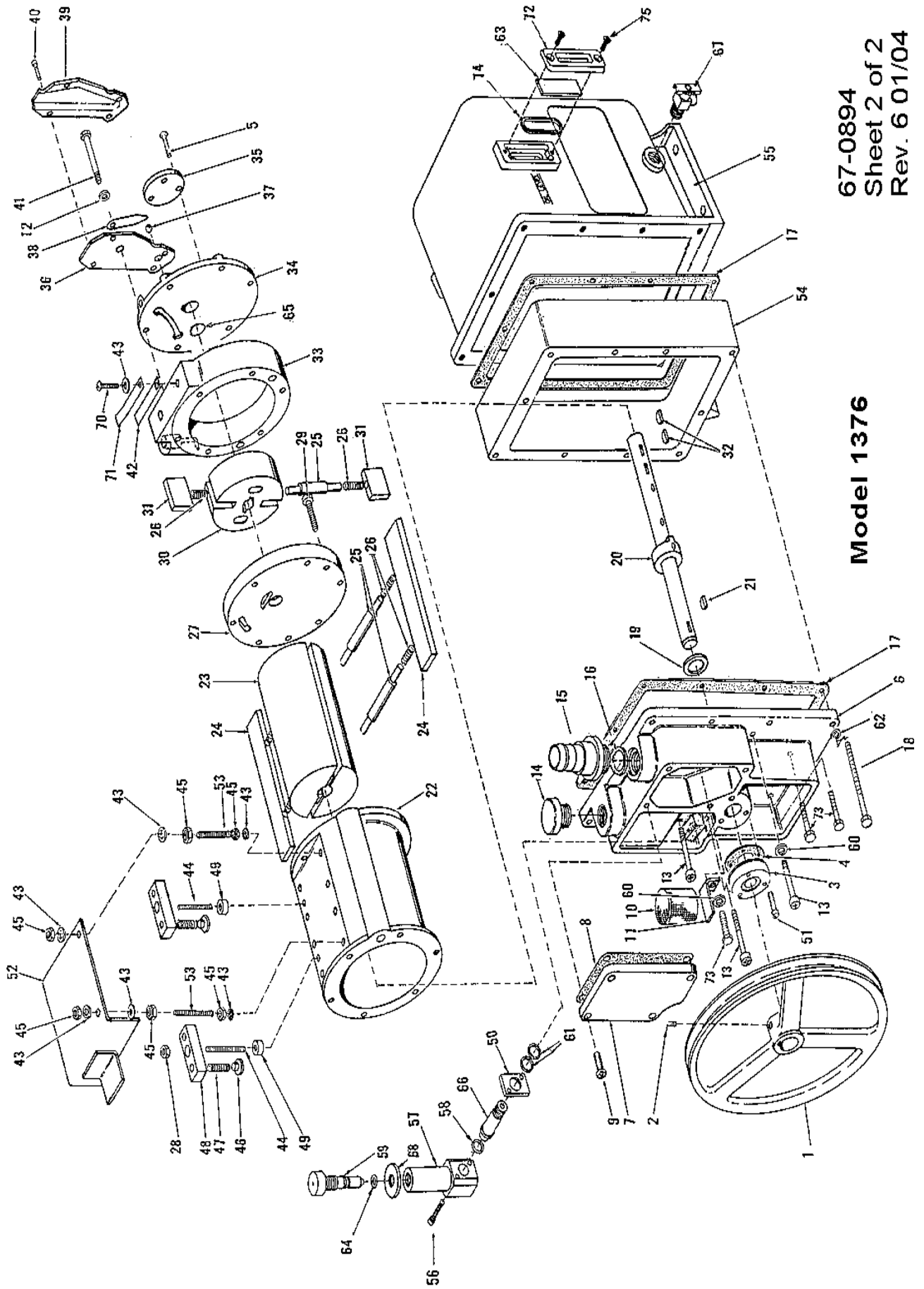

67-0894
 Sheet 2 of 2
 Rev. 6 01/04

Model 1376

PARTS LIST
MODEL 1380 VACUUM PUMP

ITEM	QUAN	PC. NO.	A*	B*	DESCRIPTION	ITEM	QUAN	PC. NO.	A*	B*	DESCRIPTION
1	1	41-2074			Pulley incl. item 2	35	3	41-1775	3	3	Lower Exhaust Valve
2	1	2-01-9306			Soc. Hd. Setscrew 5/16-18x3/8	36	3	41-0695	3	3	Upper Exhaust Valve
3	1	61-8671			Intake Cover Chamber	37	4	2-61-0000			Steel Washer 3/16
4	4	2-01-6112			Soc Hd Screw 1/4-20x3/4	38	2	2-01-5106			Rd Hd Screw 1/4-20x3/8
5	1	41-0234	1	1	Intake Cover Gasket	39	1	61-8507B			Buffle
6	1	41-0660	1	1	Air Filter	40	3	2-31-0112			Hex Nut 1/4-20
7	6	2-01-0316			Hex Hd Screw 5/16-18x1	41	1	41-2175			Special Set Screw 1/4-20x2-1/4
8	12	41-2363			Steel Washer	42	2	41-0959	2	2	Vane
9	1	41-0663			Air Filter Bracket	43	4	41-1304	4	4	Vane Spring
10	3	2-00-2706			Fil Hd Screw 10-32x3/8	44	1	41-1771			Rotor
11	1	61-8378A			Shaft Lip Seal Assy.	45	2	41-1685	2	2	Vane Spring Holder
12	1	41-0643			Seal Gasket	46	1	41-2045			Small End Plate
13	10	2-01-0114			Hex Hd. Screw 1/4-20x7/8	47	1	41-1005			Pressure Release Tube No.2
14	10	2-63-0193			Split Lock Washer 1/4	48	1	4-40-1200	1	1	Steel Ball 3/8
15	1	61-8505D			Large End Plate	49	1	41-0992	1	1	Pressure Release Valve
16	1	41-0403	1	1	Oil Case Gasket	50	6	2-01-0318			Hex Hd Screw 5/16-18x1-1/8
18	1	61-8468A			Intake Nipple	51	3	62-0259			Bind Hd Sheet Met Screw #6x1/4
19	1	61-9284A	1	1	O-ring #214	52	1	41-0986			Pressure Release Tube No.1
20	1	41-0508	1	1	Thrust Washer	53	1	41-0672			End Cap
21	1	4-06-0754			Retaining Ring	54	1	41-2757			Lock Nut
22	2	41-0624	2	2	Woodruff Key	55	1	61-8103	1	1	O-ring #905
23	1	41-1773			Shaft	56	2	41-3753			Oil Level Sight
24	1	41-1766	1	1	Thrust Disk	57	1	61-8100A			Gas Ballast Valve Adapter
25	1	61-8101			Oil Case incl. items 56, 59, 60, 61, 62	58	1	61-8101A			Gas Ballast Connector
26	1	41-1736	1	1	Gas Ballast Valve incl. item 27	59	1	61-2278			Drain Valve
27	1	41-1742			O-ring #011	60	2	61-2231	1	1	O-Ring Tetr. #127
28	2	61-8362			Soc Hd Screw 8-32x1	61	2	61-2228A			Cover, Oil Window
29	2	41-1056			Aluminum Washer	62	4	61-2232			Flat Hd Screw #8-32x1/2
30	3	2-00-6712			Soc Hd Screw 10-32x3/4			1-99-5282	1	1	Sealant, 6 cc
31	1	61-8102A			Flange For Gas Ballast			1401D	1	1	Mechanical Seal Option**
34	1	41-1772			Ring						

A*: MAJOR REPAIR KIT CAT # 1380K-04

B*: MINOR REPAIR KIT CAT # 1380K-03 .

** 1401D is mechanical seal kit includes mechanical seal, gasket and 3 screws

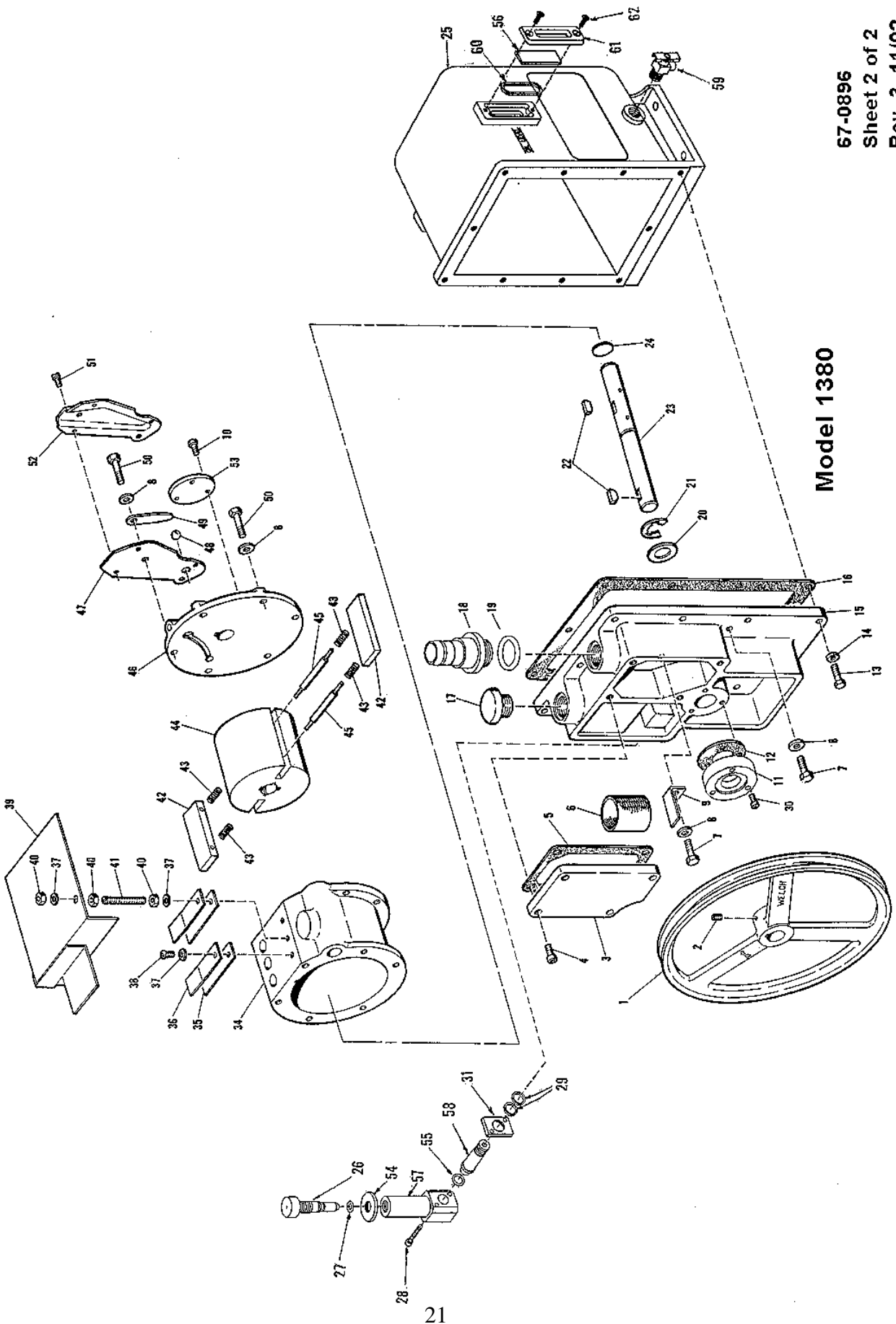

Model 1380

67-0896
 Sheet 2 of 2
 Rev. 3 11/02

PARTS LIST MODEL 1397 / 1374 VACUUMPUMP

ITEM	QUAN	PC. NO.	A*	B*	DESCRIPTION	ITEM	QUAN	PC. NO.	A*	B*	DESCRIPTION
1	1	2-01-9306			Set Screw 5/16-18x3/8	48	1	61-8101A			Connector for GB Valve
2	1	41-1492			Pulley incl. Item 1	49	5	62-0222			Soc Hd Screw 5/16-18x2-3/4
3	4	2-01-6116			Soc Hd Screw 1/4-20x1	50	1	41-1482			Oil Case Assy. incl Item 54 & (2) Items 46
4	1	61-5074			Shaft Lip Seal Assy.	51	4	62-0213			Soc Hd Screw 5/16-18x1-3/4
5	1	41-1494			Seal Gasket	52	1	61-8102A			Flange For GB Valve
6	2	41-1490	2	2	Woodruff Key	53	1	61-8103	1	1	O-Ring #905 Fluoroelastomer
7	1	41-1484			Shaft & Collar	54	1	61-2278			Drain Valve
8	2	41-1486			Leg	55	1	2-01-0344			Hex Hd Screw 5/16-18x2-3/4
9	7	2-01-6324			Soc Hd. Screw 5/16-18x1-1/2	56	3	2-00-2706			Flat Hd Screw 10-32x3/8
10	38	41-2363			Steel Washer	57	1	41-0672			Shaft End Cap
11	3	41-1137			Plug Washer	58	1	41-0992	1	1	Pressure Relief Valve
12	2	41-1136			Plug	59	1	4-40-1200	1	1	Steel Ball 3/8 Dia
13	1	61-8770			Large End Plate	60	1	41-1500			Small End Plate
14	1	41-0055			Spacer	61	1	41-1497			Exhaust Ring
15	2	2-00-2704			Flt Hd Screw 10-32x1/4	62	1	41-1499			Exhaust Rotor
20	4	2-01-6316			Soc Hd Screws 5/16-18x1	63	1	41-0696	1	1	Small Spring Holder
21	2	2-01-6320			Soc Hd Screw 5/16-18x1-1/4	64	2	41-1304	2	2	Small Vane Spring
23	1	61-8880			Cover Plate for Conversion Valve	65	2	41-1487	2		Small Vane Metal
24	1	41-1508	1	1	Valve Gasket	66	2	2-01-0316			Hex Hd Screw 5/16-18x1
25	1	41-1736			Gas Balast Valve incl. Item 45	67	1	61-8469A			Intake Nipple
26	1	41-2258			Hardened Sleeve 1/4 Size	68	1	61-8475	1	1	O-Ring #224 Fluoroelastomer
27	1	61-8538A	1	1	Valve Backer	69	4	2-01-6314			Soc Hd Screw 5/16-18x7/8
28	8	2-61-0000			Steel Washer 1/4-20 Bolt Size	70	1	61-8693			Intake Chamber
29	4	2-31-0112			Hex Steel Nut 1/4-20x7/16	71	1	41-1495	1	1	Intake Chamber Gasket
30	1	41-2253			Discharge Valve Cover	72	1	41-0937	1	1	Screen Filter
31	1	41-1465			Center Plate	73	1	61-8691			Large Ring
32	1	41-2161	1	1	Exhaust Valve	74	1	41-1478			Large Rotor
33	2	2-01-0120			Hex Hd Screw 1/4-20x1-1/4	75	2	41-1489	2	2	Large Spring Holder
34	1	41-2164			Cover	76	4	41-1488	4	4	Large Vane Spring
35	1	2-01-8132			Headless Screw 1/4-20x2	77	2	41-1477	2		Large Vane Metal
36	1	61-8310A			Pressure Release Tube Part 2	81	1	41-1516	1	1	Key for Small Rotor
37	1	41-1461			Deflector	82	4	41-1056	4	4	Aluminum Washer
38	1	61-8309B			Pressure Release Tube Part 1	83	1	41-1469	1	1	Spacer Disk
39	3	62-0259			Bd Hd Screw #6x1/4	84	1	2-63-0193			Split Lock Washer 1/4
40	1	41-1496	1	1	Oil Case Gasket	85	1	41-2256			Coil Spring
41	1	41-1501			Dust Cap	86	1	41-2257			Hardened Sleeve 5/16 Size
42	1	61-8539A	1	1	Valve Flapper	87	1	41-2553	1	1	Spacer
43	18	2-01-6316			Soc Hd Screw 5/16-18x1	89	1	61-8100A			GB Valve Adapter
45	1	41-1742	1	1	O-ring #011 Fluoroelastomer	90	1	2-69-7007			SS Washer 11/32x11/16x1/16
46	2	41-3753			Oil Sight	91	1	41-2259			Coil Spring
47	2	61-8362			Soc Hd Screw 8-32x1	92	1	41-2757			Lock Nut
						93	1	41-2165			Guard Stud
						94	2	61-8712	1	1	O-Ring #372 Fluoroelastomer
								1-99-5282	1	1	Sealant, 6 cc
								1401F	1	1	Mechanical Seal option**

A*: MAJOR REPAIR KIT CAT # 1397K-08
 B*: MINOR REPAIR KIT CAT # 1397K-07

** 1401F is mechanical seal includes mechanical seal, gasket and 4 screws
 67-0897 sheet 1 of 2
 Rev. 7 01/04

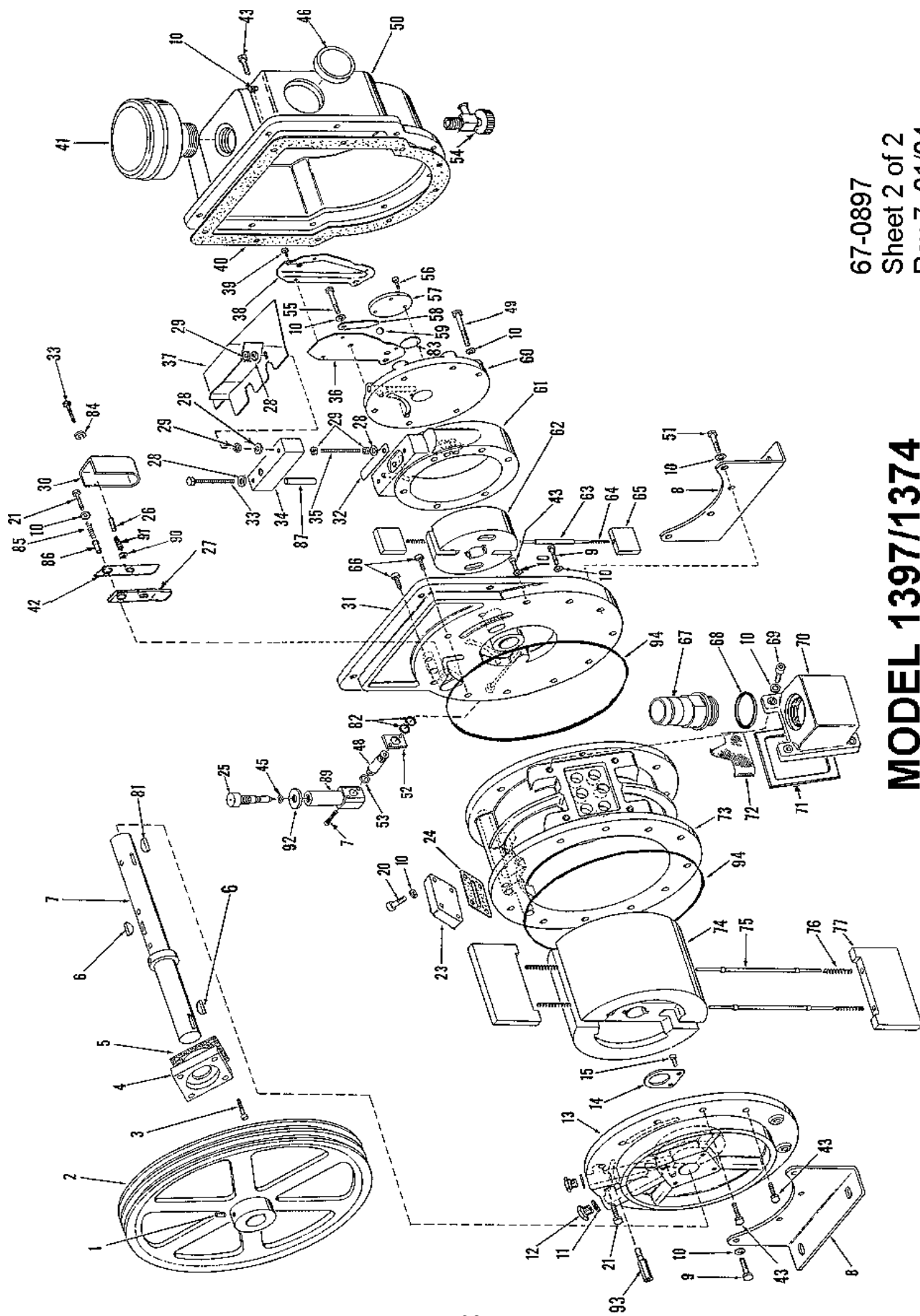

67-0897
 Sheet 2 of 2
 Rev.7 01/04

MODEL 1397/1374

PARTS LIST
MODEL 1399 VACUUM PUMP

ITEM	QUAN	A*	B*	PC. NO. DESCRIPTION	ITEM	QUAN	A*	B*	PC. NO. DESCRIPTION
1	4			Hex Hd Screw 5/16 - 18x1/2	31	1	1	1	41-0974 Retaining Ring
2	2			Leg	32	1	1	1	41-0613 Woodruff Key
9	1			Drain Valve	33	1			41-2374 Shaft
11	1			Oil Sight	34	1	1	1	41-0624 Pulley Key
12	1	1	1	Thrust Disk	35	1			41-1345 Dust Cap
13	1			Oil Case Assy. incl items 1,2,9,11	37	1			61-8467A Intake Nipple
14	1	1	1	Oil Case Gasket	38	7			2-01-6112 Soc Hd Screw 1/4-20x3/4
15	4	1	1	Fil Hd Screw 10-32x3/8	39	1			41-2367 Intake Chamber
16	1			Shaft End Cap	40	1	1	1	41-2375 Cover Gasket
17	1	1	1	Steel Washer	41	1			41-2369 Intake Chamber Cover
18	4			Hex Hd Screw 5/16 - 18x2	42	6			2-00-0716 Hex Hd Screw 10-32x1
19	4			Washer	43	1			41-0643 Seal Gasket
20	1			End Plate	44	3			2-00-6712 Soc Hd Screw 10-32x3/4
21	1			Inner Ring	45	1			41-0306 Air Filter
22	1	1	1	Exhaust Valve	46	1			41-2371 Air Filter Bracket
23	2	1	1	Brass Washer #10	47	1	1	1	1401E Shaft Seal incl. item 43 & (3) 44 ***
24	1	1	1	Valve Cover Stud	48	1			2-01-9306 Soc Hd Set Screw 5/16-18x3/8
25	1	1	1	Lock Washer #10 Ext.	49	1			41-2192 Pulley incl. item 48
26	1			Valve Cover	50	1			61-2159A O-Ring, #116, Fluoroseal
27	2	2	2	Vane					1-99-5282 Sealant, 6 cc
28	2	2	2	Spring					
29	1			Rotor					
30	1	1	1	Spring Holder					

A*: MAJOR REPAIR KIT #1399K-04
B*: MINOR REPAIR KIT #1399K-03

** 1401E is mechanical seal which fits all model 1399 serial numbers.
There is a lipseal seal on S/N 25773 and above. It is available as a kit.
part no. 1401E-01

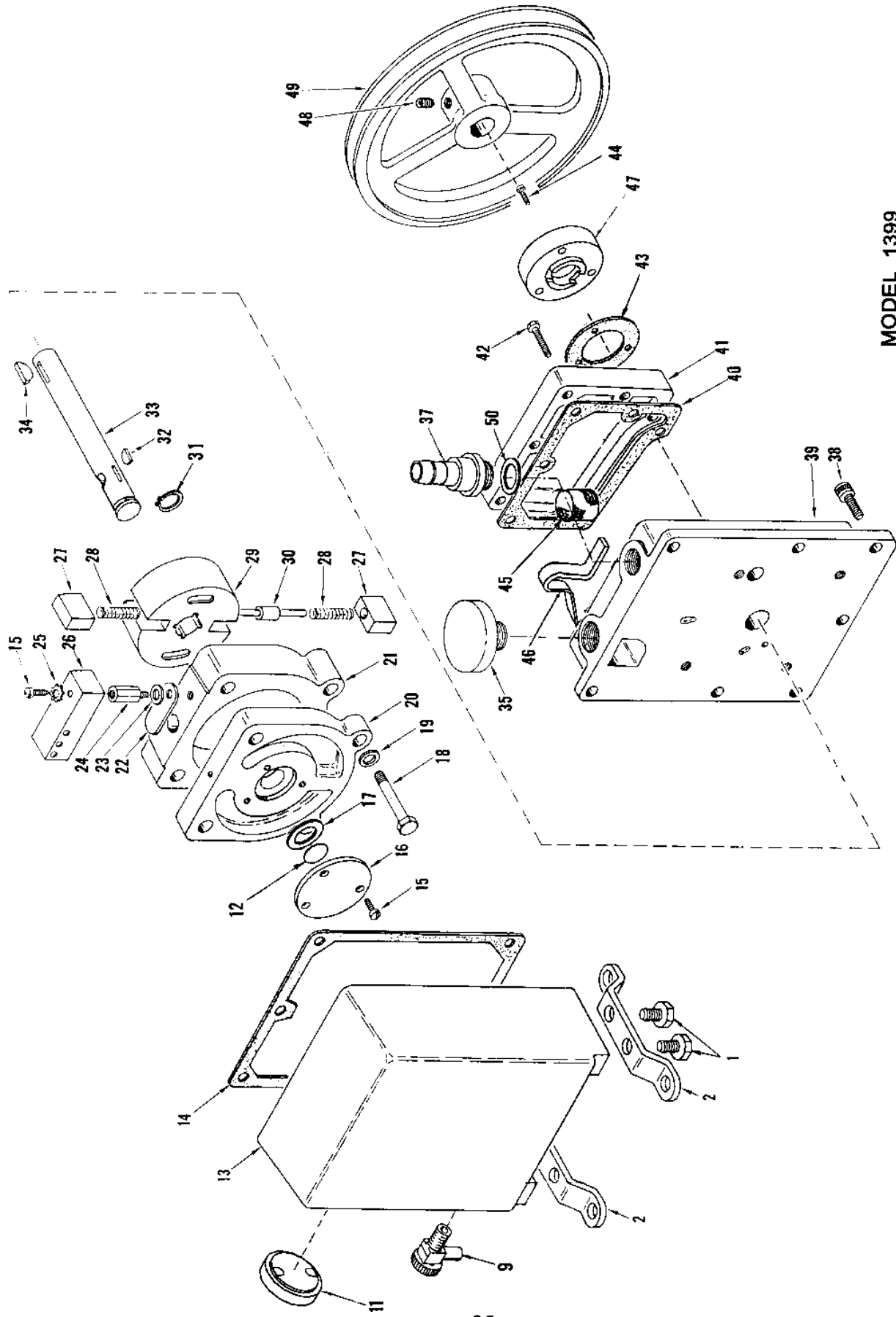

MODEL 1399

67-0899 SHEET 2 OF 2

Rev. 3 - 8/01

PARTSLIST
MODEL 1400 VACUUMPUMP

ITEM	QUAN	PC. NO.	A *	B *	DESCRIPTION	ITEM	QUAN	PC. NO.	A *	B *	DESCRIPTION
1	1	2-01-9306			Soc Hd Set Screw 5/16 - 18x3/8	35	2	2-31-2521			Hex Nut 3/8x16
2	1	41-2191			Pulley include. Set Screw , Item 1	36	1	61-8675			Intake Ring
3	1	41-3696			Shaft Seal	37	1	41-1041			Intake Rotor
4	1	41-0643			Shaft Seal Gasket	38	2	41-1063	2	2	Spring Holder
5	1	41-0624	1	1	Pulley Key	39	4	41-1304	4	4	Vane Spring
6	1	41-1060			Shaft	40	4	41-1059	4		Vane (Metal)
7	1	41-1150	1	1	Retaining Ring	41	5	2-01-0112			Hex Hd Screw 1/4 - 20x3/4
8	2	41-0613	2	2	Woodruff Key	42	1	41-1042			Exhaust Ring
10	2	41-1049			Leg	43	3	2-00-6712			Soc Hd Screw 10-32x3/4
11	6	41-1138			Washer, Copper, 7/16 OD	44	1	41-0578	1	1	Seal
12	1	41-3753			Oil Sight	45	1	61-8102A			Flange for G.B. Valve
13	1	41-1742	1	1	O-Ring #011	46	1	61-8103	1	1	O-Ring, Fluoroseal
14	1	61-8540C			Oil Case*	47	2	61-8362			Soc Hd Screw 8 - 32x1
15	1	41-1345			Dust Cap	49	1	61-2278			Drain Valve
16	1	41-1052	1	1	Oil Case Gasket	50	1	2-01-0120			Hex Hd Screw 1/4 - 20x1-1/4
17	9	2-01-0332			Hex Hd Screw 5/16 - 18x2	51	1	41-1736			Vented Exhaust Valve
18	9	41-2363			Washer	52	4	2-01-0308			Hex Hd Screw .071 Thick x 3/8 ID
19	1	41-1045			Exhaust End Plate	53	2	2-61-0571			Steel Washer .071 Thick x 3/8 ID
20	1	41-1040			Exhaust Rotor	54	1	61-2159A			O-Ring, #116, Fluoroseal
21	1	41-1239	1	1	Exhaust Valve	55	1	41-1069	1	1	Baffle Stud
22	2	2-71-0040	2	2	Brass Washer #10	56	1	61-8347B			Exhaust Baffle
23	8	41-1056			Aluminum Washer	57	1	61-8100A			Valve Adapter
24	1	41-1039			Vented Exhaust Plug	58	1	61-8101A			Connector
25	1	61-8679			Center Plate	59	1	41-2757			Locknut
26	1	41-1285			Steel Washer	60	1	61-8665	1	1	O-Ring, M2.5x86, Fluoroseal
27	1	41-0890	1	1	Air Filter	61	1	2-00-2704			Fil Hd Screw 10-32x1/4
28	1	41-0383	1	1	Gasket	62	1	61-9378	1	1	O-Ring, #152, Fluoroseal
29	1	41-1048			Intake Chamber**	63	1	66-0183	1	1	O-Ring, #120, Fluoroseal
30	1	61-8467A			Nipple			1-99-5282	1	1	Sealant 6 cc
31	2	2-01-0524			Hex Hd Screw 3/8 - 16x1-1/2			1401E	1	1	Mechanical Seal Option***
32	1	61-8702			Intake End Plate						
33	1	61-8673			End Cap						
34	5	2-00-2706			Hex Hd Screw 10 - 32x3/8						

* Oil Case Assembly PT #61-8540C includes Legs item 10, Oil Sight, item 12, oil case, Item 14, Screws, Item 52 & Drain Valve, item 49
 ** Intake Chamber Assembly PT #41-1048 includes intake chamber, item 29, nipple, Item 30 & O- ring, item 54.
 A*: Major Repair Kit #1400K-04
 B*: Minor Repair Kit #1400K-03
 *** 1401E is mechanical seal kit, it includes mechanical seal, gasket, and 3 screws

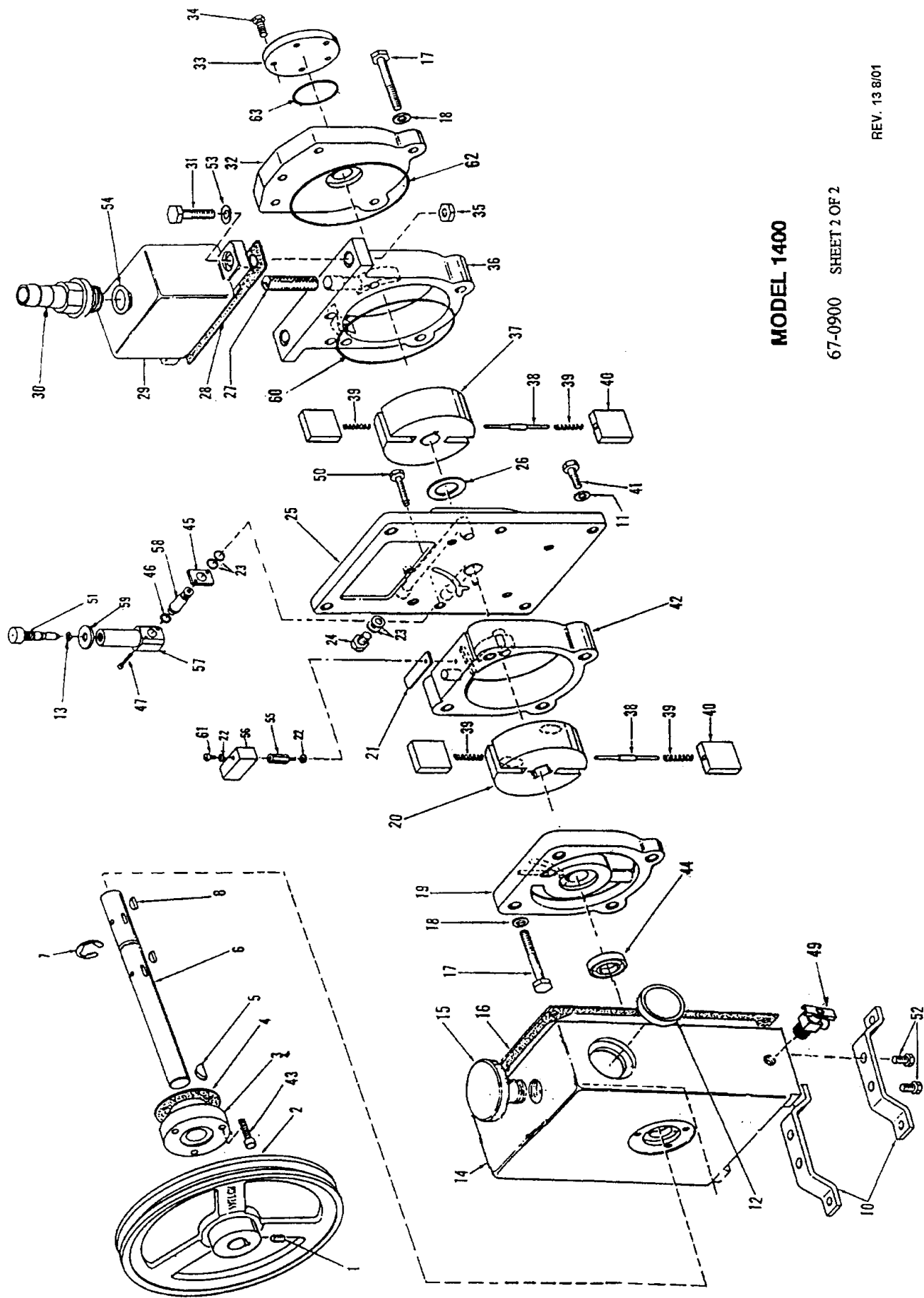

MODEL 1400

67-0900 SHEET 2 OF 2

REV. 13 8/01

PARTS LIST
MODEL 1402 VACUUM PUMP

ITEM	QTY	PC.NO.	A	B	DESCRIPTION	ITEM	QTY	PC.NO.	A	B	DESCRIPTION
01	1	61-8113C			Intake Ring	42	1	41-0234	1	1	Intake Chamber Cover Gasket
02	3	2-61-0000			Steel Washer 3/16 size	43	1	61-8329A			Air Filter Bracket
03	3	2-31-0112			Hex Steel Nut	44	6	2-01-0316			Hex Head Cap Screw 5/16-18x1
04	1	41-2159	1	1	Valve Block Spacer	45	1	41-0612			Dust Cap
05	2	61-8314A	2	2	Valve	46	1	61-8468A			Intake Nipple
06	2	41-2158	2	2	Valve Spring	47	1	61-9284A	1	1	O-Ring, Fluoroelast. #214
07	1	2-01-8128			Headless Steel Setscrew	48	1	41-0403	1	1	Oil Case Gasket
08	1	41-2156			Valve Block	49	2	61-2231	2	2	O-Ring, Fluoroelast. #127
09	1	41-1742	1	1	O-Ring, Fluoroelast. #011	50	1	61-8102A			Flange For GB. Valve
10	1	41-2160			Baffle Plate	51	1	41-1736			Gas Ballast Valve
11	1	2-36-9900			Nut, Lock 1/4-20	52	2	61-8362			Socket Head Screw 8-32x1
12	3	2-00-2706			Fil. Head Screw 10-32x3/8	53	1	61-8101			Oil Case Assy, incl. 49,56,59,76 ,77
14	1	41-2175			Headless Steel Setscrew	54	1	41-2757			Lock Nut
15	1	41-2092			Intake Rotor	55	1	61-8103	1	1	O-Ring, Fluoroelast. #905-75
17	1	61-8250C			Center Plate	56	2	61-2229A			Window Glass
19	2	2-01-6320			Socket Head Screw 5/16-18x1-1/4	57	1	61-8100A			Gas Ballast Valve Adapter
20	1	41-2154	1	1	Lower Exhaust Valve	58	1	61-8101A			Gas Ballast Valve Connector
21	1	61-8310A			Pressure Release Tube, Part 2	59	1	61-2278			Drain Valve
22	1	41-0992			Pressure Release Valve	60	6	61-8456A	6	6	Washer Copper 5/16
23	6	41-2363			Washer	61	2	41-1056			Washer
24	6	2-01-0356			Hex Head Screw 5/16-18x3-1/2	62	2	41-0613	2	2	Woodruff Key
25	3	62-0259			Self Tap Screw #6x1/4 Type "A"	63	1	41-2093			Shaft
26	1	61-8309B			Pressure Release Tube Part 1	64	2	41-0624	2	2	Woodruff Key
27	1	41-0672			End Cap	65	1	41-0508	1	1	Thrust washer
28	1	4-40-1200	1	1	Steel Ball 3/8	66	1	61-8668			Large End Plate
29	1	41-2045			Small End Plate	67	10	2-63-0193			Split Lock Washer
30	1	61-8108D			Exhaust Ring	68	10	2-01-0114			Hex Head Cap Screw 1/4-20x3/4
31	1	41-1518			Exhaust Rotor	69	1	41-0660	1	1	Air Filter
32	6	41-1304	6	6	Vane Spring	70	1	41-0643			Seal Gasket
33	2	41-1487	2	2	Small Vane	71	1	61-8378A			Shaft Lip Seal Assy.
35	2	41-0959	2	2	Large Vane	72	3	41-1685	3	3	Spring Holder - Intake
36	1	41-2074			Pulley inc. setscrew, Item 37	73	3	41-1766	3	3	Thrust Disc
37	1	2-01-9306			Socket Head Set Screw	74	1	4-06-0754	1	1	Truarc Ring
38	1	61-8671			Large End Plate Cover	75	3	2-00-6712			Socket Head Screw 10-32x3/4
39	1	41-2153	1	1	Upper Exhaust Valve	76	2	61-2370			Cover, Oil Window
40	1	2-01-5106			Rd. Head Steel Screw 1/4-20x 3/8	77	4	62-1037			Fl. Head Screw 8-32x7/16
41	4	2-01-6112			Socket Screw 1/4-20x3/4			1-99-5282	1	1	Sealant, 6 cc
								1401D	1	1	Mechanical Seal option**

A*: MAJOR REPAIR KIT CAT # 1402K-06

B*: MINOR REPAIR KIT CAT # 1402K-05

** 1401D is mechanical seal kit includes mechanical seal, gasket and 3 screws

67-0905

Sheet 1 of 2

Rev. 6 11/02

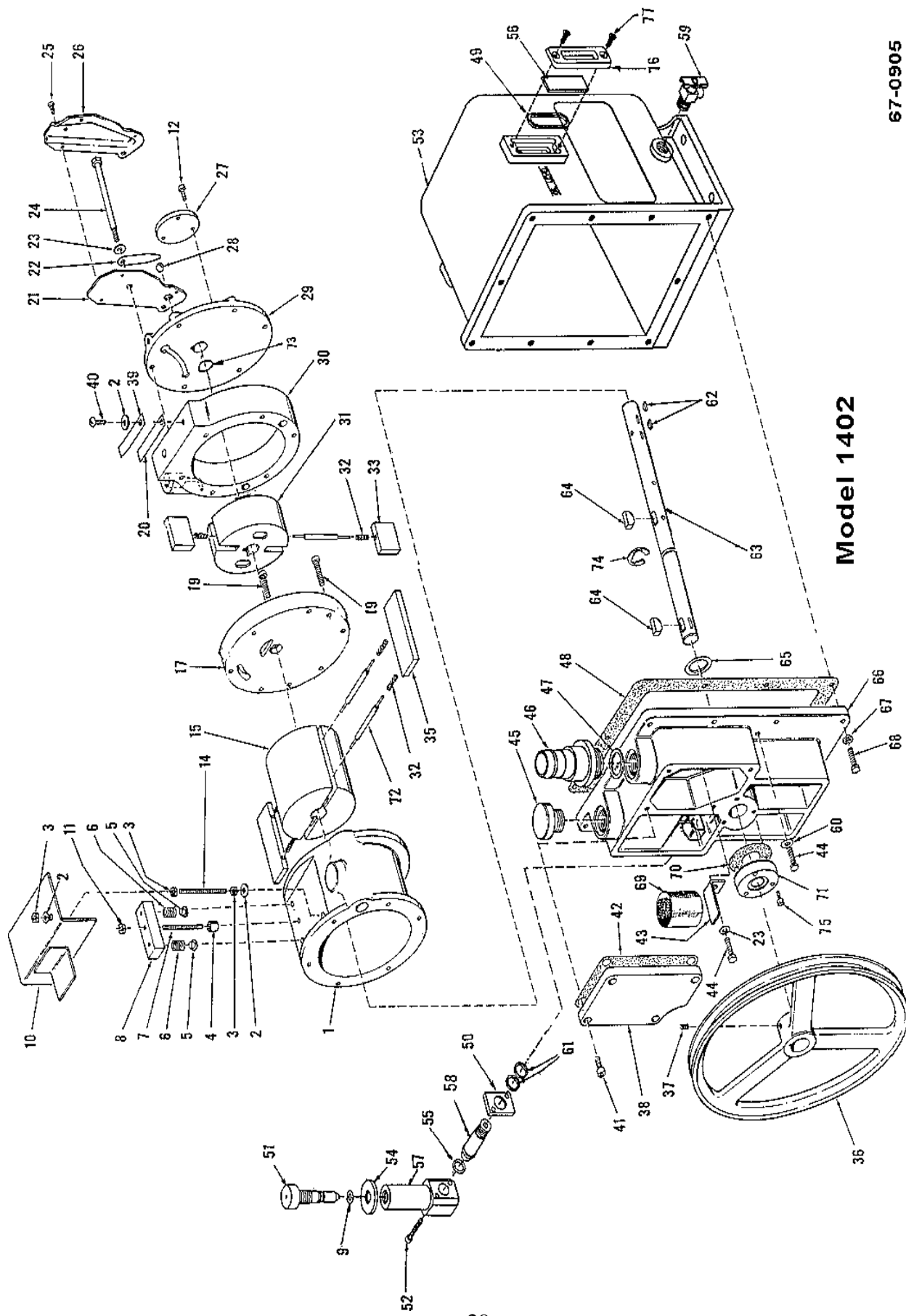

Model 1402

PARTS LIST
MODEL 1405 VACUUM PUMP

ITEM	QUAN	PC. NO.	A*	B*	DESCRIPTION	ITEM	QUAN	PC. NO.	A*	B*	DESCRIPTION
1	1	61-8651			Intake Ring	46	1	61-8641			Intake Nipple, (7/16 Hose I.D.)
2	3	2-61-0000			Steel Washer 3/16 size	47	1	61-9284A	1	1	O-ring, #214
3	3	2-31-0112			Hex. Steel Nut	48	1	41-0403	1	1	Oil Case Gasket
4	1	41-2159	1	1	Valve Block Spacer	49	2	61-2231	1	1	O-ring Tetr. #127
5	2	41-2157	2	2	Valve	50	1	61-8102A			Flange For G.B. Valve
6	2	41-2158	2	2	Valve Spring	51	1	41-1736			Gas Ballast Valve
7	1	2-01-8128			Headless Steel Set Screw	52	2	61-8362			Soc. Hd Screw 8-32x1
8	1	41-2156			Valve Block	53	1	61-8101			Oil Case Assy. incl. Items 49,56,59,76 ,77
9	1	41-1742	1	1	O-Ring #011	54	1	41-2757			Lock Nut
10	1	41-2160			Baffle Plate	55	1	61-8103	1	1	O-ring
11	1	2-36-9900			Nut, Lock 1/4-20	56	2	61-2229A			Window Glass
12	3	2-00-2706			Fl. Hd. Screw 10-32x3/8	57	1	61-8100A			Gas Ballast Valve Adapter
14	1	41-2175			Headless Steel Set Screw	58	1	61-8101A			Gas Ballast Valve Connector
15	1	41-2092			Intake Rotor	59	1	61-2278			Drain Valve
17	1	61-8250C			Center Plate	60	6	61-8456A	6	6	Washer Copper 5/16
19	2	2-01-6320			Socket Hd. Screw 5/16-18x1-1/4	61	2	41-1056			Washer
20	1	41-2154	1	1	Lower Exhaust Valve	62	2	41-0613	2	2	Woodruff Key
21	1	41-1005			Pressure Release Tube, Part 2	63	1	41-2093			Shaft
22	1	41-0992	1	1	Pressure Release Valve	64	2	41-0624	1	1	Woodruff Key
23	6	41-2363			Washer	65	1	41-0508			Thrust washer
24	6	2-01-0356			Hex. Hd Screw 5/16-18x3-1/2	66	1	61-8668			Large End Plate
25	3	62-0259			Self Tap Screw #6x1/4 Type "A"	67	10	2-63-0193			Split Lock Washer
26	1	41-0986			Pressure Release Tube Part 1	68	10	2-01-0114			Hex Head Cap Screw 1/4-20x3/4
27	1	41-0672			End Cap	69	1	41-0660	1	1	Air Filter
28	1	4-40-1200			1Steel Ball 3/8	70	1	41-0643			Seal Gasket
29	1	41-2045			Small End Plate	71	1	61-8378A			Shaft Lip Seal Assy..
30	1	61-8108D			Exhaust Ring	72	2	41-1685	2	2	Spring Holder - Intake
31	1	41-1518			Exhaust Rotor	73	3	41-1766	3	3	Thrust Disc
32	6	41-1304	2	2	Vane Spring	74	1	4-06-0754	1	1	Truarc Ring
33	2	41-1487	2	2	Small Vane	75	3	2-00-6712			Soc Hd Screw 10-32x3/4
34	1	41-0696	1	1	Vane Spring Holder-Exhaust	76	2	61-2228A			Cover, Oil Window
35	2	41-0959	2	2	Large Vane	77	4	61-2232			Fl Hd Screw 8-32x1/2
36	1	41-2074			Pulley inc. Set Screw, Item 37			1-99-5282	1	1	Sealant, 6 cc
37	1	2-01-9306			Socket Head Set Screw			1401D	1	1	Mechanical Seal Kit option **
38	1	61-8671			Large End Plate Cover			MAJOR REPAIR KIT			
39	1	41-2153	1	1	Upper Exhaust Valve			CAT # 1402K-06			
40	1	2-01-5106			Rd. Hd. Steel Screw 1/4-20x 3/8			MINOR REPAIR KIT			
41	4	2-01-6112			Socket Screw 1/4-20x3/4			CAT # 1402K-05			
42	1	41-0234	1	1	Intake Chamber Cover Gasket			1401D is mechanical seal kit includes mechanical seal, gasket and 3 screws.			
43	1	41-0663			Air Filter Bracket			67-0906			Sheet 1 of 2
44	6	2-01-0316			Hex Head Cap Screw 5/16-18x1						Rev. 7-98
45	1	41-0612			Dust Cap						

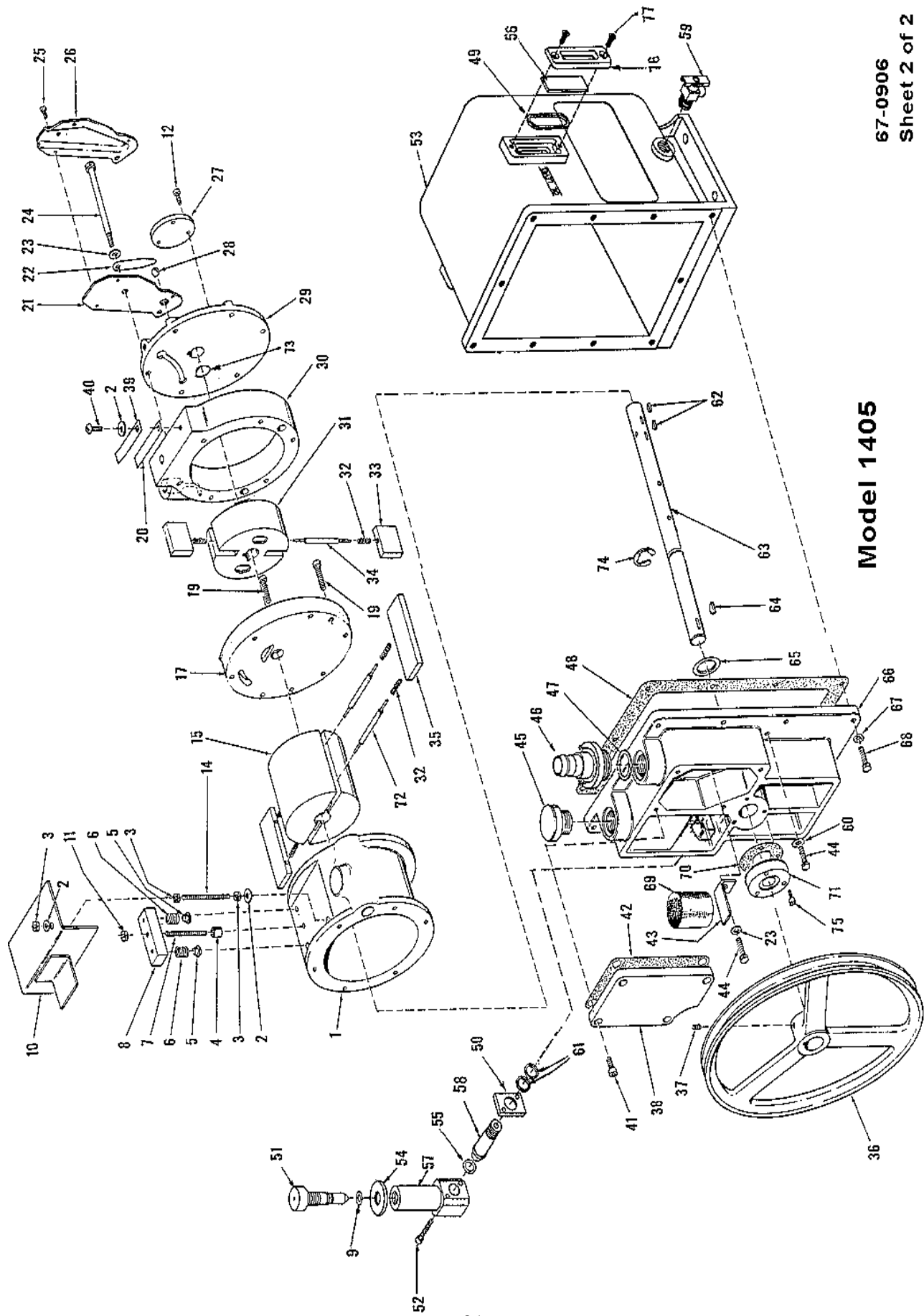

Model 1405

67-0906
 Sheet 2 of 2
 Rev. 5 11/02

Section 9: ACCESSORY SECTION

Exhaust Filters

- Filters oil mist from pump exhaust
- Filters to 0.3 micron particle size
- Easy replacement of element
- Reduces pump noise

Standard Exhaust Filters				
	Dimensions		Catalog Number	
Use with Pump Model	Diameter	Height	Filter	Replacement Element
1392, 1399, 1400	2.5	2.5	1417	1417L
1376, 1380, 1402, 1405	5.0	6.25	1417P-10	1417G
1397, 1374	5.0	9.0	1417P-20	1417H-01

Directional Exhaust Filters

- Large, high capacity
- 360° Swivel outlet with tubing connector
- Screw-in type

Directional Exhaust Filters					
	Dimensions			Catalog Number	
Use with Pump Model	Diameter	Height	Outlet Tube O.D.	Filter	Element
1376, 1380, 1402, 1405	5.0	7.5	1.0	1417A	1417G
1374, 1397	6.5	10.0	2.0	1417B	1417H
1373	5.0	7.5	1.0	1417T	1417G

Exhaust Mist Eliminator

Exhaust oil recyclers capture oil mist expelled from the pump, separate air from oil, and return collected oil to the pump via a line connected to the gas ballast inlet. This process effectively reduces oil consumption and minimizes maintenance requirements by extending the time between oil changes.

Catalog No.	Duoseal Model No.
1416H-01	1400
1416C-01	1405, 1376, 1380, 1402

- Requires gas ballast connection kit: Cat. No. 141601 - for models 1400, 1405, 1376, 1380, 1402

Coaxial Traps

- Reduces oil back streaming
- Stainless steel construction
- Easy replacement of elements

ISO Size	Capacity	Diameter	Height	A ²	Cat. No. ¹
NW16	To 4 CFM (140 L/min)	3.75	5.25	8.25	541001
NW 25	To 12 CFM (340 L/min)	5.50	5.25	8.25	541002
Copper Element for ISO NW 16 Trap ¹					541911
Stainless Steel Element for ISO NW 16 Trap ¹					541921
Copper Element for ISO NW 25 and NW 40 Traps ¹					541912
Stainless Steel Element for ISO NW 25 and NW 40 Traps ¹					541922

1. Element must be ordered with trap.
2. Distance between ISO NW inlet and outlet connections.

Modular Sieve Traps

- Blocks backstreaming by absorbing hydrocarbons.
- Regenerates charge using built-in heater.
- Removes trace amounts of water vapor.

ISO Size	Capacity	Diameter	Height	A ²	Cat. No. ¹
NW16	To 8 CFM (140 L/min)	4.50	6.38	9.00	543001
NW 25	To 8 CFM (226 L/min)	4.50	6.38	9.00	543002
NW40	To 17 CFM (481 L/min)	4.50	9.00	9.00	543003
Synthetic Zeolite Charge ¹					543950
Activated Alumina Charge ¹					543960

1. Element must be ordered with trap.
2. Distance between ISO NW inlet and outlet connections.

Dry Ice Cold Traps

- Removable 3 quarter center well for dry ice/alcohol slurry (do not use acetone)
- Visible trapping surface
- Cold temperature up to 12 hours depending on vapor load
- Available with straight tube connections

ISO Size	Diameter	Height	A ¹	I/O Offset	Cat. No.	Repl. Seal Cat.
NW 16	10	8.25	11.06	3.5	545001	545200
NW 25	10	8.25	11.06	3.5	545002	545200
Straight Tube						
½ O.D.	10	8.25	10.75	3.5	1420H-14	545200

1. Distance between ISO NW inlet and outlet connections.

Liquid Nitrogen Cold Traps

- A highly efficient method of trapping condensable vapors
- Produces a lower mechanical vacuum pump base pressure
- Allows quick clean-up of the trapping surface with the two-piece clamped body design

ISO Size	Capacity	Diameter	Height	A ¹	Cat. No.
NW 16	0.75 Liter	5.5	11.00	7.0	546001
NW 25	0.75 Liter	5.5	11.00	7.0	546002

1. Distance between ISO NW inlet and outlet connections.



MATERIAL SAFETY DATA SHEET

HMIS Rating: Health: 0 Flammability: 1 Reactivity: 0 Special: X

SECTION 1 - IDENTIFICATION

Chemical Name: Highly-Refined Petroleum Lubricant Oils

Synonyms: 1407K DUOSEAL Vacuum Pump Oil

Formula: N/A

Manufacturer's Name: Welch Rietschle Thomas
7301 North Central Ave.
Skokie, IL 60077

Date Prepared: November 11, 2003

Telephone Number for
General Information: (847) 676-8800

SECTION 2 - COMPOSITION

Exposure Limits in Air

<u>Component</u>	<u>CAS No.</u>	<u>OSHA PEL</u>	<u>ACGIH TVL</u>
Highly-Refined Petroleum Lubricant Oils	64741-88-4	NO	NO

To the best of our knowledge, the above listed component is not hazardous according to OSHA (1910.1200) or one or more state right-to-know lists.

SECTION 3 - HAZARDS IDENTIFICATION

Major Route of Entry: Skin contact

Signs and Symptoms of Acute Exposure

Inhalation: No significant adverse health effects are expected to occur upon short-term exposure to this product. Aspiration of liquid into the lungs can cause severe lung damage or death.

Eye Contact: Minimal eye irritation may result from short term contact with liquid, mist, and/or vapor.

Skin Contact: This material can cause mild skin irritation from prolonged or repeated skin contact. Injection

under the skin, in muscle, or into the blood stream can cause irritation, inflammation, swelling, fever, and systemic effects and mild central nervous system depression. Injection of pressurized hydrocarbons can cause severe, permanent tissue damage. Initial symptoms may be minor. Injection of petroleum hydrocarbons requires immediate medical attention.

Ingestion: If swallowed, large volumes of material can cause generalized depression, headache, drowsiness, nausea, vomiting and diarrhea. Smaller doses can cause a laxative effect. If aspirated into the lungs, liquid can cause lung damage.

Chronic Health Effects Summary:

Contains a petroleum-based mineral oil. Prolonged or repeated skin contact can cause mild irritation and inflammation characterized by drying, cracking, (dermatitis) or oil acne. Inhalation of petroleum-based mineral oils can cause respiratory irritation or other pulmonary effects after repeated or prolonged inhalation of oil mists at concentrations above applicable workplace exposure levels.

THE INFORMATION HEREIN IS GIVEN IN GOOD FAITH, BUT NO WARRANTY, EXPRESS OR IMPLIED, IS MADE.

Revision Date: 11/11/03

Rev. 4

P/N: 67-0254 1 of 6

Chemtech Scientific provides access to this content as a courtesy.
We do not own the content contained in this document.
All rights and credit go directly to its rightful owners.
www.chemtechsci.com
Call us at: 484-424-9415



Conditions Aggravated

by Exposure: Personnel with pre-existing disorders should avoid repeated or prolonged contact with this product.
Target Organs: Skin
Carcinogenic Potential: This product does not contain any components at concentrations above 0.1% which are considered carcinogenic by OSHA, IARC, or NTP.

SECTION 4 - FIRST AID MEASURES

Take proper precautions to ensure your own health and safety before attempting rescue or providing first aid. For more specific information, refer to Exposure Controls and Personal Protection in Section 8 of this MSDS.

Inhalation: Vaporization is not expected at ambient temperatures. This material is not expected to cause inhalation-related disorders under anticipated conditions of use. In case of overexposure, move the person to fresh air.

Eye Contact: Check for and remove contact lenses. Flush eyes with cool, clean, low-pressure water while occasionally lifting and lowering eyelids. Seek medical attention if excessive tearing, redness, or pain persists.

Skin Contact: Remove contaminated shoes and clothing. Wipe off excess material. Wash exposed skin with soap and water. Seek medical attention if tissue appears damaged or if irritation persists. Thoroughly clean contaminated clothing before reuse. Discard contaminated leather goods. If material is injected under the skin, into muscle, or into the blood stream, seek medical attention immediately.

Ingestion: Do not induce vomiting unless directed to by a physician. Do not give anything to drink unless directed to by a physician. Never give anything by mouth to a person who is not fully conscious. If large amounts are swallowed or irritation or discomfort occurs, seek medical attention immediately.

Notes to Physician: The viscosity range of the product(s) represented by this MSDS is 100 to 400 SUS at 100°F. Accordingly, upon ingestion there is a low to moderate risk of aspiration. Careful gastric lavage may be considered to evacuate large quantities of material. Subcutaneous or intramuscular injections requires prompt surgical debridement.

SECTION 5 - FIRE FIGHTING MEASURES

NFPA Flammability

Classification: OSHA/NFPA Class-IIIB combustible liquid. Slightly combustible!

Flash Point/Method: CLOSED CUP: 210°C(410°F). (Pensky-Martens (ASTM D-93)) OPEN CUP: 238°C(460°F) (Cleveland.).

Lower Flammable Limit: No data

Upper Flammable Limit: No data

Auto-Ignition Temp.: Not available

Hazardous Combustion Products: Carbon Dioxide, carbon monoxide, smoke fumes, unburned hydrocarbons and trace oxides of Sulfur and/or nitrogen.

Special Properties: When heated above its flash point temperature, this material will release vapors which, if exposed to an ignition source, can ignite. In enclosed spaces vapors can ignite with explosive force. Mists or sprays may burn at temperatures below the flash point.

Extinguishing Media: Use dry chemical, foam, Carbon Dioxide or water fog.

Fire Fighting Protective Clothing: Firefighters must use full bunker gear including NIOSH-approved positive pressure self-contained breathing apparatus to protect against potential hazardous combustion or decomposition products and oxygen deficiencies

THE INFORMATION HEREIN IS GIVEN IN GOOD FAITH, BUT NO WARRANTY, EXPRESS OR IMPLIED, IS MADE.

Revision Date: 11/11/03

Rev. 4

P/N: 67-0254 2 of 6



SECTION 6 - ACCIDENTAL RELEASE MEASURES

Take proper precautions to ensure your own health and safety before attempting spill control or clean-up. For more specific information, refer to Emergency Overview on Page 1, Exposure Controls and Personal Protection in Section 8, and Disposal Considerations in Section 13 of this MSDS.

Do not touch damaged containers or spilled material unless wearing appropriate protective equipment. Slipping hazard; do not walk through spilled material. Stop leak if you can do so without risk. For small spills, absorb or cover with dry earth, sand, or other inert non-combustible absorbent material and place into waste containers for later disposal. Contain large spills to maximize product recovery or disposal. Prevent entry into waterways or sewers. In urban area, cleanup spill as soon as possible. In natural environments, seek cleanup advice from specialists to minimize physical habitat damage. This material will float on water. Absorbent pads and similar materials can be used. Comply with all laws and regulations.

SECTION 7 - HANDLING AND STORAGE

Handling: Avoid water contamination and extreme temperatures to minimize product degradation. Empty containers may contain product residues that can ignite with explosive force. Do not pressurize, cut, weld, brase solder, drill, grind or expose containers to flames, sparks, heat or other potential ignition sources. Consult appropriate federal, state and local authorities before reusing, reconditioning, reclaiming, recycling or disposing of empty containers and/or waste residues of this product.

Storage: Keep container closed. Do not store with strong oxidizing agents. Do not store at temperatures above 120°F or in direct sunlight for extended periods of time. Consult appropriate federal, state, and local authorities before reusing, reconditioning, reclaiming, recycling or disposing of empty containers or waste residues of this product.

SECTION 8 - EXPOSURE CONTROLS AND PERSONAL PROTECTION

Engineering Controls: Provide exhaust ventilation or other engineering controls to keep the airborne concentrations of mists and/or vapors below the recommended exposure limits (see below). An eye wash station and safety shower should be located near the work-station.

Personal Protective Equipment: Personal protective equipment should be selected based upon the conditions under which this material is used. A hazard assessment of the work area for PPE requirements should be conducted by a qualified professional pursuant to OSHA regulations. For certain operations, additional PPE may be required.

Eye Protection: Safety glasses equipped with side shields should be adequate protection under most conditions of use. Wear goggles and/or face shield if splashing or spraying is likely, especially if material is heated above 125°F (or 51°C). Have suitable eye wash water available.

Hand Protection: Use gloves constructed of chemical resistant materials such as neoprene or heavy nitrile rubber if frequent or prolonged contact is expected. Use heat-protective gloves when handling product at elevated temperatures.

Body Protection: Use clean and impervious protective clothing (e.g., neoprene or Tyvek®) if splashing or spraying conditions are present. Protective clothing may include long-sleeve outer garment, apron, or lab coat. If significant contact occurs, remove oil-contaminated clothing as soon as possible and promptly shower. Launder contaminated before reuse or discard. Wear heat protective boots and protective clothing when handling material at elevated temperatures.

Respiratory Protection: Vaporization or misting is not expected at ambient temperatures. Therefore, the need for Respiratory protection is not anticipated under normal use conditions and with adequate ventilation. If elevated airborne concentrations above applicable workplace exposure levels are anticipated, a NIOSH-approved organic vapor respirator equipped with a dust/mist

THE INFORMATION HEREIN IS GIVEN IN GOOD FAITH, BUT NO WARRANTY, EXPRESS OR IMPLIED, IS MADE.

Revision Date: 11/11/03

Rev. 4

P/N: 67-0254 3 of 6

Chemtech Scientific provides access to this content as a courtesy.
We do not own the content contained in this document.
All rights and credit go directly to its rightful owners.
www.chemtechsci.com
Call us at: 484-424-9415



General Comments:

prefilter should be used. Protection factors vary depending upon the type of respirator used. Respirators should be used in accordance with OSHA requirements (29 CFR 1910.134). Use good personal hygiene practices. Wash hands and other exposed skin areas with plenty of mild soap and water before eating, drinking, smoking, use of toilet facilities, or leaving work. DO NOT use gasoline, kerosene, solvents, or harsh abrasive skin cleaners. Since specific exposure standards/control limits have not been established for this product, the "Oil Mist, Mineral" exposure limits shown below are suggested as minimum control guidelines.

Occupational Exposure

Guidelines Substance: Oil mist, mineral

Applicable Workplace

Exposure Levels: TWA: 5 (mg/M³) from ACGIH (United States)
STEL: 10 (mg/M³) ACGIH (United States)
TWA: 5 (mg/M³) from OSHA (United States)

SECTION 9 – PHYSICAL AND CHEMICAL PROPERTIES

Physical State: Liquid	Color: Light Amber to Amber
Odor: Mild Petroleum Odor	Specific Gravity: 0.88(Water = 1)
pH: N/A	Vapor Density: GT 1 (Air = 1)
Boiling Point/Range: N/A	Melting/Freezing Point: N/A
Vapor Pressure: 0.01mm of Hg (20°C)	Viscosity (cSt @ 40°C): 65
Density: 7.30 Lbs/gal.	Solubility in Water: Insoluble in cold water
Viscosity (ASTM D2161) = 339 SUS @ 100°F	Volatile Characteristics: Negligible volatility
Additional Properties: Gravity, API (ASTM D287) = 30.0 @ 60°F	

SECTION 10 – STABILITY AND REACTIVITY

Chemical Stability: Stable

Hazardous Polymerization: Not expected to occur.

Conditions to Avoid: Keep away from extreme heat, sparks, open flame and strong oxidizing conditions.

Materials Incompatibility: Strong oxidizers

Hazardous Decomposition Products: No additional hazardous decomposition products were identified other than the combustion products identified in section 5 of this MSDS.

SECTION 11 – TOXICOLOGICAL INFORMATION

For other health-related information, refer to the Emergency Overview on Page 1, and the Hazards identification in Section 3 of this MSDS.

Toxicity Data:	Distillates, petroleum, solvent-refined heavy paraffinic:
ORAL (LD50):	Acute: >5000 mg/kg [Rat].
DERMAL (LD50):	Acute: >2000 mg/kg [Rabbit].

Distillates, petroleum, solvent-refined heavy paraffinic:

Mineral oil mists derived from highly refined oils are reported to have low acute and sub-acute toxicities in animals. Effects from single and short-term repeated exposures to high concentrations of mineral oil mists well above applicable workplace exposure levels include lung inflammatory reaction, lipid granuloma formation and lipid pneumonia. In acute and sub-acute studies involving exposures to lower concentrations of mineral oil mists at or near current workplace exposure levels produced no significant toxicological effects. In long term studies (up to two years) no carcinogenic effects have been reported in any animal species tested. Analyses conducted by method IP346 indicate that the polycyclic aromatic concentration of this mineral oil is below 3.0 weight percent.

THE INFORMATION HEREIN IS GIVEN IN GOOD FAITH, BUT NO WARRANTY, EXPRESS OR IMPLIED, IS MADE.

Revision Date: 11/11/03

Rev. 4

P/N: 67-0254 4 of 6

Chemtech Scientific provides access to this content as a courtesy.
We do not own the content contained in this document.
All rights and credit go directly to its rightful owners.
www.chemtechsci.com
Call us at: 484-424-9415



SECTION 12 – ECOLOGICAL INFORMATION

- Eco-toxicity:** Analysis for ecological effects has not been conducted on this product. However, if spilled, this product and any contaminated soil or water may be harmful to human, animal, and aquatic life. Also, the coating action associated with petroleum and petroleum products can be harmful or fatal to aquatic life and waterfowl.
- Environmental Fate:** An environmental fate analysis has not been conducted on this specific product. However, plants and animals may experience harmful or fatal effects when coated with petroleum-based products. Petroleum-based (mineral) lube oils will normally float on water. In stagnant or slow-flowing waterways, an oil layer can cover a large surface area. As a result, this oil layer might limit or eliminate natural atmospheric oxygen transport into the water. With time, if not removed, oxygen depletion in the waterway might be enough to cause a fish kill or create an anaerobic environment.

SECTION 13 – DISPOSAL CONSIDERATIONS

Hazard characteristic and regulatory waste stream classification can change product use. Accordingly, it is the responsibility of the user to determine the proper storage, transportation, treatment and/or disposal methodologies for spent materials and residues at the time of disposition.

Conditions of use may cause this material to become a hazardous waste, as defined by Federal or State regulations. It is the responsibility of the user to determine if the material is a hazardous waste at the time of disposal. Transportation, treatment, storage and disposal of waste material must be conducted in accordance with RCRA regulations (see 40 CFR 260 through 40 CFR 271). State and/or local regulations may be more restrictive. Contact the RCRA/Superfund Hotline at (800) 424-9346 or your regional US EPA office for guidance concerning case specific disposal issues.

SECTION 14 – TRANSPORT INFORMATION

- DOT Status:** Not regulated by the U.S. Department of Transportation as a hazardous material.
- Proper Shipping Name:** Not regulated
- Hazard Class:** Not regulated
- Packing Group(s):** Not applicable
- UN/NA ID:** Not regulated
- Reportable Quantity:** A Reportable Quantity (RQ) has not been established for any components of this material.
- Placards:** Not applicable.
- Emergency Response Guide No.:** Not applicable.
- HAZMAT STCC No.:** 2911990
- MARPOL III Status:** Not a DOT “Marine Pollutant” per 49 CFR 171.8

SECTION 15 – REGULATORY INFORMATION

- TSCA Inventory:** This product and/or its components are listed on the Toxic Substance Control Act (TSCA) Inventory.
- SARA 302/304:** The Superfund Amendments and Reauthorization Act of 1986 (SARA) Title III requires Facilities subject to Subparts 302 and 304 to submit emergency planning and notification information based on Threshold Planning Quantities (TPQs) and Reportable Quantities (RQs) for “Extremely Hazardous Substances” listed in 40 CFR 302.4 and 40 CFR 355. No components were identified.
- SARA 311/312:** The Superfund Amendments and Reauthorization Act of 1989 (SARA) Title III Requires

THE INFORMATION HEREIN IS GIVEN IN GOOD FAITH, BUT NO WARRANTY, EXPRESS OR IMPLIED, IS MADE.

Revision Date: 11/11/03

Rev. 4

P/N: 67-0254 5 of 6



facilities subject to this subpart to submit aggregate information on chemicals by "Hazard Category" as defined in 40 CFR 370.2. This material would be classified under the following hazard categories: No SARA 311/312 Hazard categories identified.

SARA 313:

This product contains the following components in concentrations above de minimis levels that are listed as toxic chemicals in 40 CFR Part 372 pursuant to the requirements of Section 313 of SARA: No components were identified.

CERCLA:

The Comprehensive Environmental Response, Compensation, and Liability Act of 1980 (CERCLA) requires notification of the National Response Center concerning release of quantities of "hazardous substances" equal to or greater than the reportable quantities (RQs) listed in 40 CFR 302.4. As defined by CERCLA, the term "hazardous substance" does not include petroleum, including crude oil or any fraction thereof which is not otherwise specifically designated in 40 CFR 302.4. This product or refinery stream is not known to contain chemical substances subject to this statute. However, it is recommended that you contact state and local authorities to determine if there are any other reporting requirements in the event of a spill.

CWA:

This material is classified as an oil under Section 311 of the Clean Air Act (CWA) and the Oil Pollution Act of 1990 (OPA). Discharges or spills which produce a visible sheen on waters of the United States, their adjoining shorelines, or into conduits leading to surface waters must be reported to the EPA's National Response Center at (800) 424-8802.

California

Proposition 65:

This material may contain the following components which are known to the State of California to cause cancer, birth defects or other reproductive harm, and may be subject to the requirements of California Proposition 65 (CA Health & Safety Code Section 25249.5):
Toluene: 0.0008%

New Jersey

Right-To-Know Label: Petroleum Oil

Additional Regulatory

Remarks: No additional regulatory remarks.

SECTION 16 – OTHER INFORMATION

Revision: 4

Revision Date: 11/11/03

ABBREVIATIONS :

AP= Approximately

EQ= Equal

GT= Grater Than

LT= Less Than

NA= Not Applicable

ND= No Data

NE= Not Established

ACGIH= American Conference of Governmental Industrial Hygienists

AIHA= American Ind. Hygiene Association IARC= Internal Agency for Research on Cancer

NTP= National Toxicology Program NIOSH= National Institute of Occupational Safety and Health

OSHA= Occupational Safety and Health Administration

NPCA= National Paint and Coating Manufactures Association

HMIS= hazardous Materials Information System

NFPA= National Fire Protection Association EPA= Environmental Protection Agency

All statements, information, and data provided in this Material Safety Data Sheet are believed to be accurate and reliable, but are presented without guarantee, warranty, or responsibility of any kind, expressed or implied on our part. Users should make their own investigations to determine the suitability of the information of products for their particular purpose.

Welch and DUOSEAL is a registered trademark of Welch Rietschle Thomas.

THE INFORMATION HEREIN IS GIVEN IN GOOD FAITH, BUT NO WARRANTY, EXPRESS OR IMPLIED, IS MADE.

Revision Date: 11/11/03

Rev. 4

P/N: 67-0254 6 of 6

WARRANTY

UNPACKING

Inspect the pump carefully. If any damage has occurred, file claim with the carrier immediately. Save the shipping container for carrier to inspect.

OPERATING PUMP

Refer to the enclosed Instruction/Operation Manual for all information to properly operate and maintain the pump.

WARRANTY

This Welch Vacuum product is warranted to be free from defects in material and workmanship. The liability of Welch Rietschle Thomas under this warranty is limited to servicing, adjusting, repairing or replacing any unit or component part which in the judgment of Welch Rietschle Thomas has not been misused, abused or altered in any way causing impaired performance or rendering it inoperative. No other warranties are expressed or implied. The method of executing this warranty: servicing, adjusting, repairing or replacing shall be at the discretion of Welch Rietschle Thomas. Vacuum pumps that have been used for any period, however short, will be repaired under this warranty rather than replaced.

The warranty is effective for one year from the date of original purchase when:

1. The warranty card has been completed and returned.
2. The product is returned to the factory or other designated service centers, freight prepaid.
3. The product in our judgment is defective through no action or fault of the user.

If the product has become defective through misuse, abuse, or alteration, repairs will be billed regardless of the age of the product. In this event, an estimate of the repair costs will be submitted and authorization of these charges will be required before the product is repaired and returned.

To reduce additional charges and delays either within or outside of the warranty period, contact Welch Rietschle Thomas @847-676-8800 for a return authorization number. Products without a return authorization number will be refused by our receiving department. Before shipping, properly pack the pump, insure it against loss or damage, and on the outside of the pump packaging and the packing slip write in the return authorization number. Pumps damaged due to improper packaging are the customer's responsibility.