

Chemtech Scientific provides access to this content as a courtesy.
We do not own the content contained in this document.
All rights and credit go directly to its rightful owners.
www.chemtechsci.com
Call us at: 484-424-9415

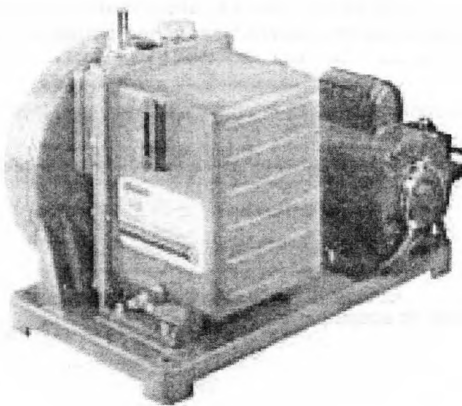

OWNER'S MANUAL FOR GEM® DIRECT-DRIVE VACUUM PUMP MODEL 8890



WARNING

Never Block the Exhaust Port. If the exhaust is blocked, pressure will build-up in the pump with the potential of the pump body bursting and causing possible injury to personnel in the area.

**Part No. 61-1172AR1.7
Printed in U.S.A.**

PLEASE READ BEFORE OPERATION

While reading your manual, please pay close attention to areas labeled **WARNING AND CAUTIONS**. The description of each is found below.

WARNING

Warnings are given where failure to observe instruction could result in injury or death to people

CAUTION

Cautions are found where failure to observe the instruction should result in damage to the equipment, associated equipment and process.

These units conform to the SI International system of units of measurement.

The following symbols (with recommendations of IEC1010) of warning will be found on the pump.

Caution - refer to accompanying documents



Caution - risk of electrical shock



Caution - hot surface



WARNING

Motor includes a self resetting thermal cut-out and the pump could restart without actuation under fault condition.

TABLE OF CONTENTS

Warranty	4
Section 1 – Installation	5
Section 2 – Pump Features and Principles of Operation	8
Section 3 – Specifications	13
Section 4 – Parts List and Exploded Pump View	16
Section 5 – Operation	18
Section 6 – Maintenance and Troubleshooting	19
Section 7 – Repair Service	22
Section 8 – Accessories & MSDS for Directorr Premium Oil	23

WARRANTY

This Welch Rietschle Thomas product is warranted to be free from defects in material and workmanship. This liability of Welch Rietschle Thomas under this warranty is limited to servicing, adjusting, repairing or replacing any unit or component part which in the judgment of Welch Rietschle Thomas has not been misused, abused or altered in any way or damaged by ingestion of foreign material causing impaired performance or rendering it inoperative. Foreign material includes solids, liquids, corrosive gases and recondensed water or solvent vapor. No other warranties are expressed or implied. The method of executing this warranty: servicing, adjusting, repairing or replacing shall be at the discretion of Welch Rietschle Thomas. Vacuum pumps that have been operated within a vacuum system, or other system, for any period, however short, will be repaired under this warranty rather than replaced.

The warranty is effective for one year from the date of original purchase when:

1. The warranty card has been completed and returned.
2. The product is returned to the factory or other designated service centers, freight prepaid.
3. The product in our judgment is defective through no action or fault of the user.

If the product has become defective through misuse, abuse, alteration or ingestion of foreign materials, repairs will be billed regardless of the age of the product. In this event, an estimate of the repair costs will be submitted and authorization of these charges will be required before the product is repaired and returned.

Section 1: INSTALLATION

1.1 Introduction

The tradename of this pump is GEM®, because of its suitability for the following laboratory applications:

Evaporators, such as the rotary type
Manifolds for vacuum

This pump also is well suited for use in gas analyzers, continuous gas-flow lasers, general-purpose drying, and similar uses where a middle-range vacuum level is required. It is a good replacement for diaphragm (membrane) and water aspirator pumps.

Its unique, patented technology permits pumping at any pressure range from 0.1 mm Hg (100 microns) to atmospheric. At these higher pressures, the pump uses the gas it is pumping to remove heat. Rotary-vane pumps typically run hotter at these pressures, due to greater frictional forces.

This manual has been written for the care and maintenance of the Model 8890 Vacuum Pump. Take time to read it carefully, and keep it for future reference. One of the most important aspects of any pump installation is the precautions taken to prevent condensable vapors from collecting in the pump. Pay particular attention to Section 1-10 for ways to effectively pump condensable vapors.

1.2 Unpacking

Carefully remove the pump from the shipping carton. Keep all paperwork and inspection tags for future reference. If shipping damage has occurred, a claim must be filed with the carrier immediately; keep the shipping container for inspection by the carrier.

1.3 Pump Mounting

Rubber bumpers are supplied with the pump base. They isolate noise and eliminate creeping. For more rigid mounting requirements the pump base can be the bumper holes to put the mounting bolts through. Refer to Section 3 – Specifications for mounting hold location dimensions.

1.4 Pump Location

The pump should be located in a clean and well-ventilated area and adequate space should be provided wherever possible for routine maintenance such as oil changes. For best performance, the pump should be located as closely as possible to its system. Determining factors for pump locations should include length and size of connections, the number of bends, and the type of exhaust connections.

1.5 Exhaust Provisions

Exhaust connections will be determined by the type of system to be exhausted and desired cleanliness of the air surrounding the pump. Under normal pumping conditions nothing more than the optional exhaust filter will be necessary. Refer to Section 9 – Accessories for various exhaust filters available. Where extreme exhaust conditions are encountered, it is best to pipe the filter exhaust out of the building. The pump's exhaust connection is a threaded port, 3/4-20, located opposite the inlet port on top of the oil reservoir. It will accept the Model 1417 Exhaust Filter, which is furnished with the pump, or can be used with the Model 1396J Hose Nipple, for 7/16 in. ID hose.



WARNING

Never block or impede air flow from the exhaust port. High pressure can build up within the oil reservoir if the exhaust flow is blocked. Check frequently, especially if exhaust is piped out of the building.

1.6 Electric Power

Compare the pump motor rating, printed on a label on the side of the motor, to the power source, to be sure they agree in voltage, phase, and frequency. Pump installation must comply with local electrical codes which dictate appropriate protection devices such as fuses or circuit breakers. We strongly suggest that you learn the location and operation of the circuit breaker or fuse protecting the electrical outlet for the pump so that you can react quickly in the event of an emergency.

The vacuum pump motor is factory wired to for 115 V for models which operate from 60 Hz, and 220 V for models which operate from 50 Hz. The motor wiring can easily be changed for operation at a voltage different than that set at the factory. Follow the motor wiring schematic diagrams in Section 3-2 – Motor Power Specifications and Special Features.

Identification Symbols:

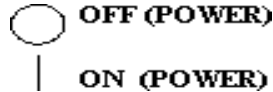

CAUTION

Only a qualified technician should attempt motor rewiring. Motor lead wires can be accessed by removing the four screws on the top lid of the motor junction box.

1.7 Vacuum Connections

The pump inlet is equipped with a hose barb nipple for connection of 3/8 in. ID hose. It is located next to the pump handle.

The choice of connections and fittings can have a very marked effect on the pumping speed at the vacuum chamber. Any connection placed between the pump and the chamber creates an impedance to the flow of gas. This is particularly true at low pressures in the millitorr range where the gas flow is substantially molecular in character. The gas flow is then dependent upon the kinetic activity of the molecules to bring it to the pump intake.

The conductance of a tube is proportional to the cube of its diameter and inversely proportional to its length. Therefore, connecting lines should be as large in diameter and as short in length as practical. For best results the connection tube should be at least as large as the diameter of the pump intake. To avoid a large reduction in pumping speed at the vacuum chamber, the conductance of the line must be considerably greater than the speed of the pump.

1.8 Vacuum Gauges

The type of vacuum gauge to be used in a system is determined largely by the pressure range to be measured. A thermocouple gauge or a dial-type gauge, is recommended for measuring pressures in the range produced by this pump. See Section 9 – Accessories.

1.9 Vacuum Pump Oil



CAUTION

The vacuum pump is shipped without oil inside to prevent possible spillage during shipment. Oil must be added prior to use.

Remove the fill plug located on the top of the oil case and add the oil supplied in a bottle packaged with each pump. Both the fill and drain plugs have knurled edge and a center slot for easy turning either by hand or with a screwdriver.

Be sure the pump is filled with oil to the level indicated on the oil fill window. When additional oil is required, use only DIRECTORR® Premium Vacuum Pump Oil; pump performance is not guaranteed with other brands of oil. Do not overfill the pump, and be sure to replace the oil fill plug.

After the pump has been running for at least 15 minutes, check the oil level again. The oil level should be maintained between the “add” mark and the “full” mark on the oil level window while the pump is operating. Do not overfill; excess oil tends to be splashed out the pump exhaust. The ideal level is four “ribs” down from the top of the oil case, or about ½ in. below the “full” mark.

1.10 Pumping Condensable Vapors

Liquids can collect in a vacuum pump by either being ingested or sucked directly into the pump, or by its vapors condensing in the pump.

If the application requires pumping directly on a liquid, or on samples whose surface contain large amounts of liquid, the initial pumping may draw some of this liquid directly into the pump. The use of a liquid trap is recommended. A plastic flask of sufficient size is often adequate. Place it nearest the source of the liquid being pumped. Inlet and outlet connections should be made at or near the top to prevent any of the trapped liquid from being drawn out by the pump.

To prevent condensable vapors from condensing in the vacuum pump, several measures should be taken. These include:

- A. Control of the pressure in the vacuum system. Not all vacuum systems need to, or should be, operated at the lowest pressure possible for the pump. Rotary evaporators, for example, depend on a pressure setpoint high enough to prevent the distillate collected from reevaporating. If reevaporized, it can easily recondense in the pump.
Use of a bleed valve and pressure gauge is recommended.
Use the Cat. No. 1423 Vacuum Manifold Valve/Gauge Kit.
- B. Trap condensable vapors in a cold trap. If the pressure of the system must be set at or near the ultimate pressure of the pump, or if the vapor load is high, use a cold trap is recommended. It should be placed away from sources of heat, such as the pump, for maximum efficiency.

Several types of cold traps are available. They include:

- 1) Dry Ice/Alcohol Slurry Traps which maintain a temperature of about -75 C .
- 2) Liquid Nitrogen Traps which maintain a temperature of about -100 C .
- 3) Refrigerated Traps which typically maintain temperatures between about -25 to -80 C .

See Section 9 – Accessories for a selection of these traps. Consult a handbook for the melting temperatures of the liquids being pumped. Some very heavy vapor loads may require these of two traps in series. Once the trap is installed and charged, wait for it to reach its minimum temperature before turning on the vacuum pump. The condensed vapor must be removed from the trap on a frequent basis to prevent reevaporation via sublimation, and to allow the trap to work at its peak efficiency.

Section 2: PUMP FEATURES AND PRINCIPLES OF OPERATION

2.1 General Description

The Model 8890 Vacuum Pump is a two-stage, direct-drive gerotor pump featuring:

- a. Capacity of 28 Liters/Minute (1 CFM).
- b. Ultimate pressure of 0.1 mm Hg (100 microns)
- c. Intake isolation valve available on certain models
- d. Continuous operation at intake pressures from 100 microns too atmospheric.

For clarity, the modular vacuum pump assembly is referred to as the pump in this section.

2.2 Principles of Vacuum Pump Operation

The main purpose of a vacuum pump is to reduce the pressure in a vessel or a closed system. The degree of pressure reduction is dependent upon the requirements of the application and the type of vacuum pump employed. Mechanical, rotary, oil-sealed pump operation is described in this section because of its similarities to the pumping action of this gerotor gear pump.

Pressure reduction in a closed system is accomplished by repeatedly removing a portion of the original volume of gas contained in the system. Removal is performed by the action of the rotating elements of the pump which cause a given space to be successively enlarged and diminished. Figure 2-1 illustrates a section through a typical stage of a rotary vane pump. Note that this figure is not intended to illustrate the internal components of a gerotor pump such as the Model 8890; its purpose is to illustrate the general operating principles of vacuum pumps.

The rotary action of the pump creates a hollow space or chamber (1) which expands as the pump rotates. As the chamber expands, the pressure in the chamber decreases. As a result, gas is drawn into the chamber due to the difference in pressure between the chamber and the inlet (4) to the chamber. (The inlet is the only place where gas can flow into the chamber.)

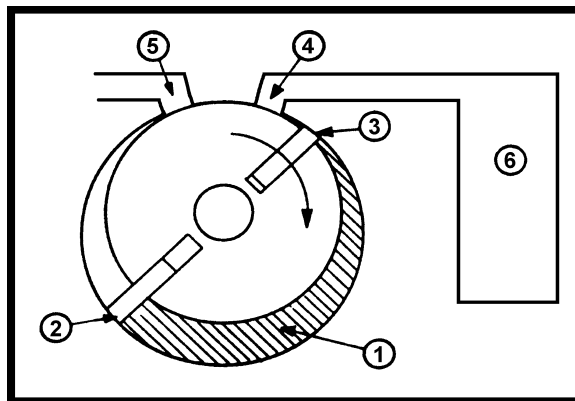

Figure 2.1
Typical Rotary Vane Pump,
Schematic Diagram

Once the vane (3) moves past the inlet (4), it seals the inlet against the chamber (1), and the gas becomes trapped between the vanes (2 and 3). The chamber (1) formed by the enclosed space between the vanes then begins to decrease in volume as the rotor revolves, compressing the gas. The pressure of the compressed gas becomes greater than atmospheric pressure. When the vane (2) moves past the exhaust port (5) the compressed gas in the chamber is forced out through the exhaust port.

This expansion/compression cycle constitutes one complete cycle of pump operation. This cycle is repeated as the vane (2) passes the intake port and seals it against the atmosphere. Therefore, two pump cycles are performed during each revolution of the pump rotor.

2.3 Effects of Continued Pressure Reduction

The quantity of gas in the vessel (6) is reduced with each evacuation cycle. The gas remaining in the vessel expands to fill the vessel and consequently with each cycle the pressure in the vessel is reduced. This is a manifestation of Boyle's law which states that for a constant temperature, the volume of a body of gas is inversely proportional to its pressure, i.e. if the volume is enlarged the pressure must be reduced.

As the amount of gas in the vessel is steadily diminished, its pressure is correspondingly reduced. The action of the pump must therefore compress a successively smaller quantity of gas with each cycle to something greater than atmospheric pressure in order to expel it from the pump.

At the beginning of an evacuation sequence, the compression ration is very small. In the first cycle of operation the pump draws in a volume of gas at atmospheric pressure and expels it at approximately atmospheric pressure. In contrast, at ultimate pressure, a pump draws in gas at (for example) 100 millitorr and must compress it to more than 760,000 millitorr (atmospheric pressure) in order to expel it from the pump. Since the exhaust valve is generally spring loaded to provide a good seal, the pressure required to open it is somewhat greater than atmospheric pressure. Therefore, at an ultimate pressure of 100 millitorr (1×10^{-3} Torr) the compression ration performed by the pump is approximately 10,000 to 1.

2.4 Ultimate Pressure

As described previously, a quantity of gas is removed from the system with each cycle of the pump. Therefore, the pressure of the gas remaining in the system is reduced with each pump cycle. Since the pump can remove only a small portion of the gas with each pump cycle, it is obvious that this method of evacuation can never completely remove all the gas in the vessel. In addition, all the components of the system contain minute sources of gas leakage which are impossible to seal completely against atmospheric pressure. Outgassing of materials within the system provide additional sources of gas.

As a result, after prolonged pumping, a state of equilibrium is reached in which the gas introduced from all the leakage sources is balanced by the ability of the pump to remove gas from the system. This state of equilibrium is referred to as the ultimate pressure, or blankoff pressure, of the pump and its system. No matter how much additional pumping time is provided, no further reduction in system pressure will be accomplished once ultimate pressure is attained.

2.5 The Gerotor Vacuum Pump

The Model 8890 Vacuum Pump uses patented technology, (U.S Patent No. 4,519,755) developed by Welch Vacuum, employing two gerotor stages to pump gases. Each gerotor stage consists of an inner rotor and an outer rotor. Figure 2-2 is a cutaway view of a single gerotor pump showing the inner and outer rotors. There is a one-tooth differential between the two rotors; the inner rotor has one less tooth than the outer rotor. The inside diameter of the outer rotor is somewhat larger than the outside diameter of the inner rotor.

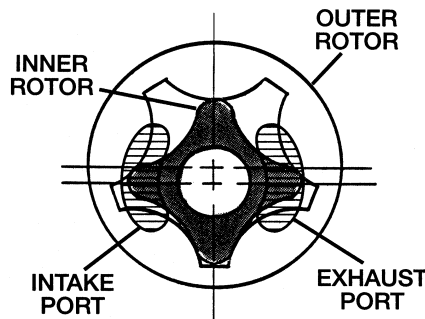

Figure 2.2
Gerotor Pump Chamber,
Schematic Diagram

The outer rotor is held in place by a housing and is free to rotate within the housing. The pump shaft drives the inner rotor, which in turn drives the outer rotor in the same direction, but at a slower speed.

In a gerotor pump, the pumping chamber is created between the inner and outer rotors. The boundaries of the chamber are defined by the two contact areas where the teeth of the inner rotor meet the teeth of the outer rotor. As the two rotors revolve, the resulting speed differential between the inner and outer rotors creates a pumping chamber which is constantly moving. The chamber expands and contracts as the rotors turn. Inlet and outlet ports are placed to allow gas to enter and exit the pumping chamber at the proper points. These ports, in conjunction with the movement of the chamber, produce pumping action. A film of oil acts as a sealant and lubricant between the two rotors, allowing pumping down to relatively low pressure levels. Because the relative velocity between the inner and outer rotors is low, there is minimal wear of the rotating parts. As a result, the gerotor pump is very reliable.

2.6 Pump Mechanism Description

The Model 8890 Vacuum Pump incorporates two separate in-line gerotor stages with interconnecting ports. Relative to each other, the intake stage is at high pressure and the exhaust stage is at low pressure. Each stage contains a two piece gerotor assembly consisting of an inner drive rotor and an outer driven rotor; the two stages are enclosed in a common gerotor housing. The shaft turns the drive rotor which then drives the driven rotor. Each stage has an exhaust valve with a backer valve; the backer valve prevents excessive exhaust valve travel. The intake gerotor stage, which is the larger of the two stages, is closest to the driven end of the shaft. The intake gerotor is larger in volume and its size determines the pumping rate of the pump. See Figure 2-3.

Gas from the system being evacuated flows into the inlet of the intake gerotor and is compressed in the gerotor chamber. At the beginning of a pump down, the pressure of the compressed gas is sufficient to force the bypass valve open, so most of the compressed gas is forced out the bypass valve and is vented to the atmosphere. As the evacuation of the system continues, the pressure of the compressed gas eventually reaches a point where it is not sufficient to force the bypass valve open.

Figure 2.3
Two Stage Gerotor Pump,
Cutaway View

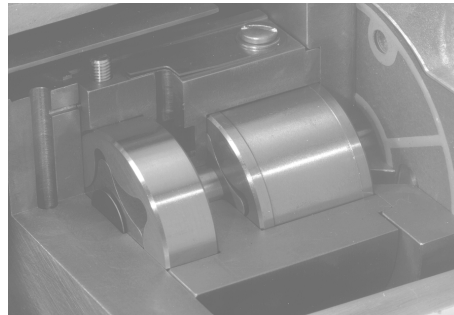

At this point, all of the compressed gas instead flows from the intake gerotor into the inlet of the exhaust gerotor, is compressed again, and with the help of the lubricating oil, pushes the exhaust valve open. From there, the compressed gas flows out the pump's exhaust port and is vented to the atmosphere. Both the bypass valve and the exhaust valve have backer valves to provide extra opening resistance.

A small orifice is located in the exhaust stage. The function of this orifice is to reduce the noise level of the pump. The orifice allows a small amount of air at atmospheric pressure to enter the gas being discharged from the exhaust stage. This reduces the pressure differential between the atmosphere and the gas leaving the pump, thereby reducing noise from the pump exhaust. When the pump motor is shut off while the pump is still connected to a vacuum, the orifice vents the pump, preventing oil suckback.

The pump is mounted inside an oil case which is a reservoir for the oil that lubricates the pump. The motor shaft drives the pump shaft via an electric motor coupling. There is a coupling body on the end of each shaft; a coupling spider between the two coupling bodies transfers the power from the motor shaft to the pump shaft.

2.7 Pump Lubrication

To ensure efficient operation and proper maintenance, and to minimize noise and oil vapors, it is important to use the correct type and quantity of oil. DIRECTORR® Premium Vacuum Pump Oil has been especially developed to have the proper viscosity, low vapor pressure, and chemical stability needed to produce peak pumping efficiency. The ultimate vacuum guarantee on this pump applies only when DIRECTORR® Premium oil is used. Each pump is supplied with a bottle of oil sufficient for filling. Additional oil is available. See Section 9 – Accessories for sizes available.

Oil is fed into the pumping chamber by the differential pressures created by the rotation of the pump. Oil metered into the pump through a narrow opening is sufficient to lubricate and seal the moving parts, permitting the pumping of gas at relatively low pressure levels.

2.8 Intake Isolation Valve Models

Cat. No. 8890A-55, 8890C-56 and 8890C-57 Vacuum Pumps have a solenoid-operated isolation valve in the pump intake. When power to the pump is turned off, this valve closes automatically, maintaining vacuum in the system being evacuated, and vents the inside of the pump to atmospheric pressure. The solenoid is wired to the pump's ON/OFF switch. When the pump is turned on, the spring-loaded solenoid plunger is pulled down, but the isolation valve remains held against the pump intake by the pressure differential between that of the pump and chamber. After a very short time, the pressure of the pump equals the pressure in the chamber, at which time the isolation valve drops due to its own weight, opening then take of the pump to allow gas to flow into the pump again. Figure 2.4 illustrates the components of the valve.

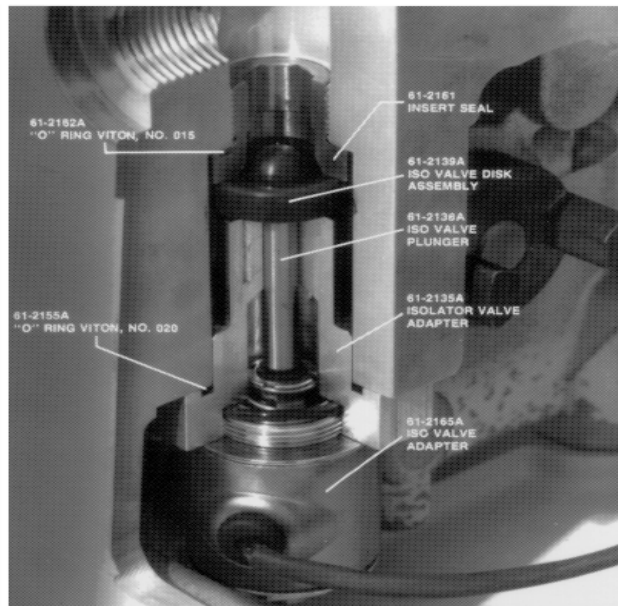

Figure 2.4
Intake Isolation Valve,
Cutaway View

2.9 Exhaust Filter

Any oil-sealed vacuum pump tends to discharge oil mist from its exhaust port when the pump operates under high flow conditions, such as when the pump's intake is at or near atmospheric pressure. Typically, oil mist in the form of a white puff of "smoke" can be seen from the exhaust port when no filter is used. Once the vacuum level and the corresponding air flow through the pump are reduced, very little, if any, oil mist will be emitted. An exhaust filter is recommended when the pump operates at relatively high intake pressure for any length of time. Oil droplets entrained in the pump's exhaust are removed by the exhaust filter element. Use of an exhaust filter typically reduces or baffles pump noise as well. Exhaust filters are sometimes referred to as Oil Mist Eliminators, or as Smoke Eliminators. A Model 8817 Exhaust Filter is furnished with each pump. See Section 10-Accessories for a selection of additional filters available.

Section 3: SPECIFICATIONS

Table 3.1 Pump Specifications

Model	8890
Number of Stages	2
Free Air Displacement CFM (L/min.) @60 Hz (L/min.)m ³ /h @50 Hz	1.1 (31) (26) 1.56
Guaranteed Ultimate Pressure * Torr (mbar)	1.0 x 10 ⁻¹ (1.3)
Sound Level dBA	58
Motor/Pump Speed rpm @60 Hz rpm @50 Hz	3450 2875
Motor Current Draw	3.0A @ 115V or 1.5A @ 230V
Motor Horsepower	1/4
Oil Capacity liters (quarts)	0.45 (0.48)
Intake Connection, 1/4 NPT threaded nipple	3/8" Hose Barb
Tubing I.D. Required	3/8"
Exhaust Connection	3/4-20 threaded
Pump Weight lbs. (Kg.)	24.5 (11.1)
Overall Dimension L inches (cm) W inches (cm) H inches (cm)	14.5 (36.8) 5.1 (13.0) 8.4 (21.3)
Shipping Weight lbs. (Kg.)	26 (11.8)
Shipping Carton Dimension L inches (cm) W inches (cm) H inches (cm)	15.5 (39.4) 7.0 (17.8) 10.0 (25.4)
Exhaust Filter Cat. No.	1417
Filter Replaceable Element Cat. No.	1417L
Repair Kit Cat. No.	8890K-02
Oil Type, DIRECTORR Premium Cat. No.	8995P-11 (1 Liter)

* Partial measurement based upon the American Vacuum Society Test Procedure No. AVS 5.1-1963 using a trapped McLeod Gauge.

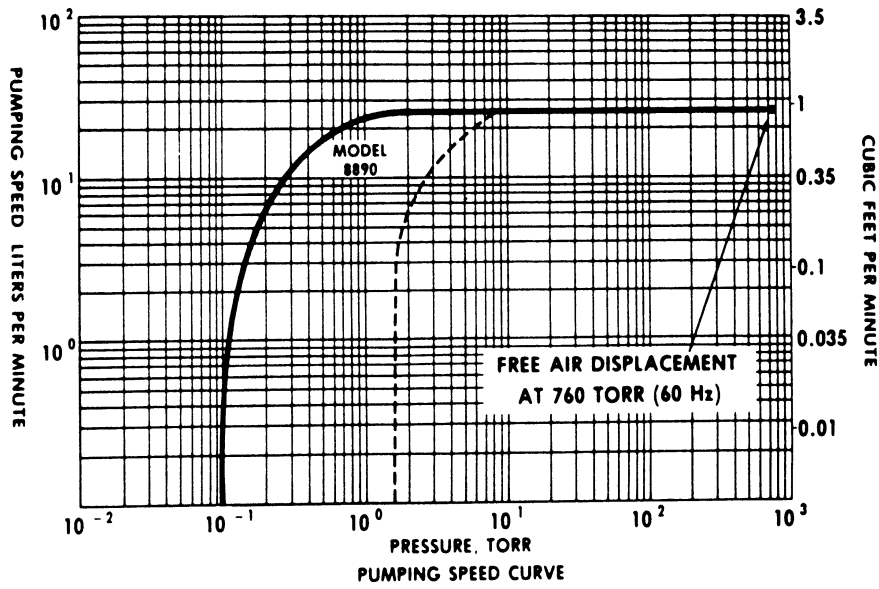

Figure 3.1 Pumping Speed Curve of Model 8890 Vacuum Pump

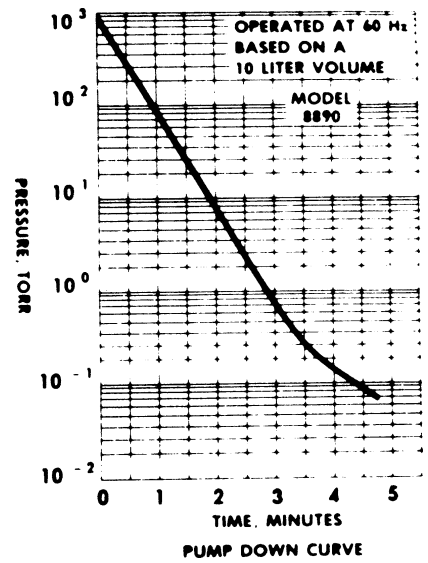

Figure 3.2 Pump Down Curve of Model 8890 Vacuum Pump

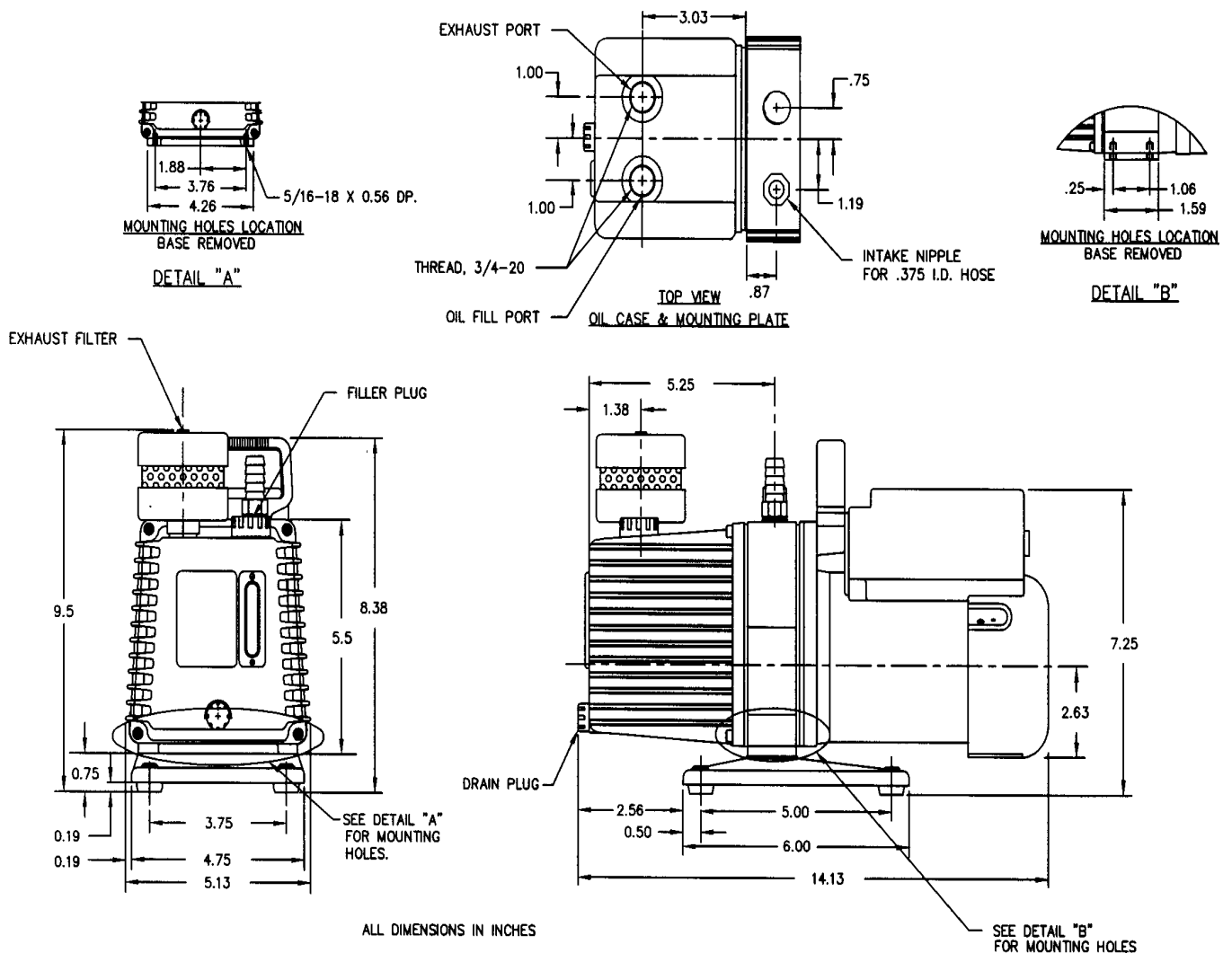

Figure 3.3 Dimensional Drawings, Model 8890 Vacuum Pump

Table 3.2 Motor Power Specifications and Special Features, Model 8890

Cat. No.	Voltage	Freq.	Phase	Factory Wired For	Special Feature
8890A	115/230	60	1	115 V	
8890A-55	115/230	60	1	115 V	Isolation Valve
8890A-85	115/230	60	1	115 V	Prepared for use with Fomblin YL-VAC-06/6, Isolation Valve
8890C-01	115/230	60	1	230 V	North American Plug
8890C-02	115/230	50	1	220 V	European Schuko Plug
8890C-56	115/230	60	1	230 V	N. American Plug, Iso. Valve
8890C-57	115/230	50	1	220 V	Euro. Plug, Iso. Valve

Models can be easily rewired to operate at either the low (115 V) or high (220-230V) voltage. When changing the factory wiring, replace the line cord plug with one suitable for the voltage connection which meets the local electrical codes. Figure 3-4 shows the electrical schematic for low voltage; Figure 3-5 shows it for high voltage. This applies to Franklin Electric Motors, Model No. 1603007401, and 1603007402, for both 50 and 60 Hz operation.

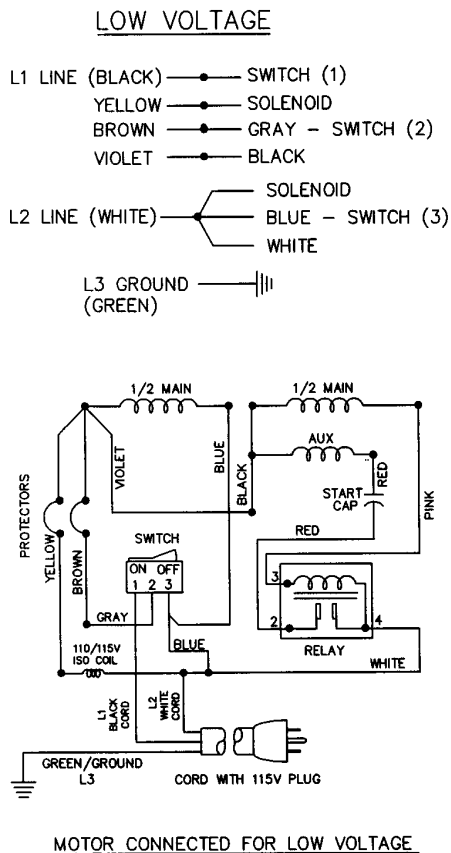

Figure 3.4 Electrical Wiring Wiring Diagram, Low Voltage

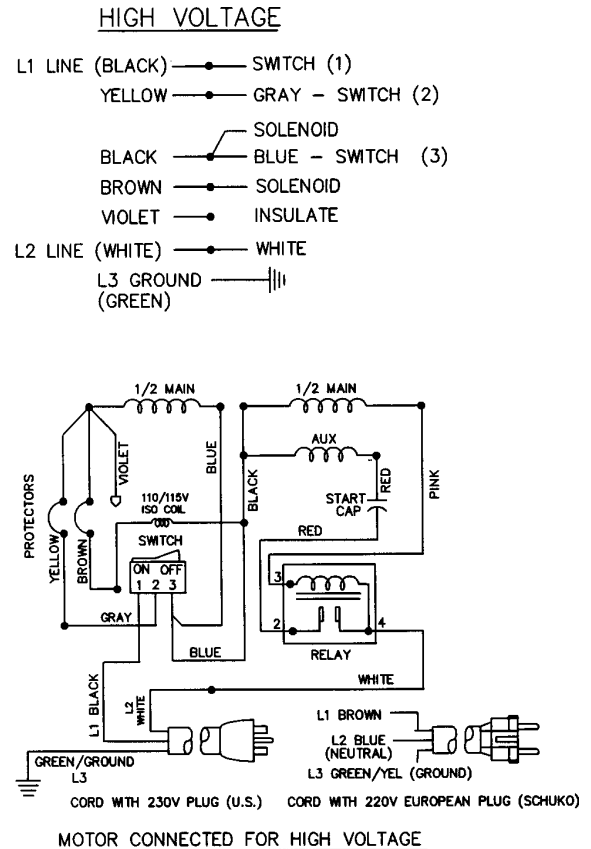
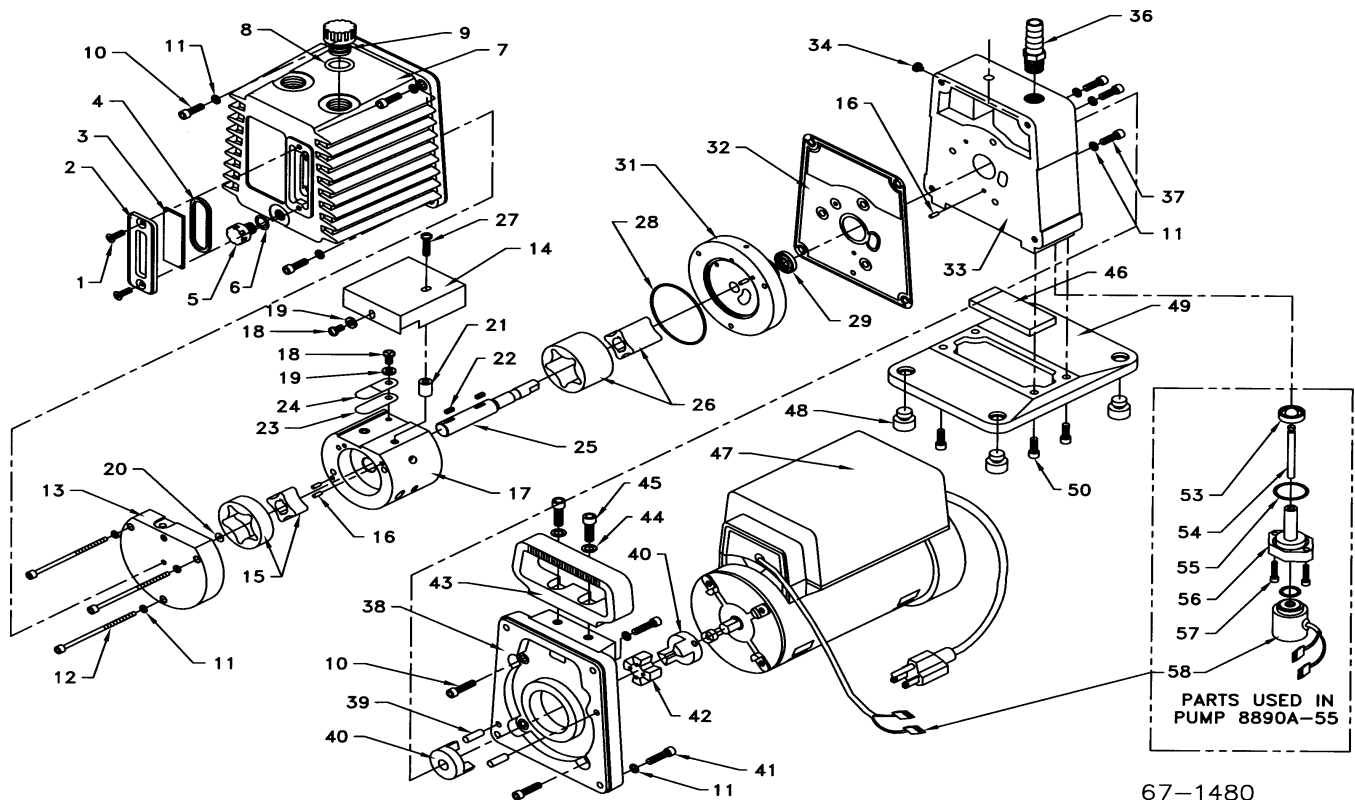

Figure 3.5 Electrical Wiring Schematic Diagram, High Voltage



Model 8890A

67-1480
Sheet 2 of 2
Rev. 2 6/04

PARTS LIST 8890A VACUUM PUMP

ITEM	QTY	PC.NO.	A*	B*	DESCRIPTION	ITEM	QTY	PC.NO.	A*	B*	DESCRIPTION
01	2	62-1037			Screw, Fillisterhead, #8-32x7/16	32	1	61-1119B	1		Gasket
02	1	61-2370			Window Holder	33	1	61-1318			Mounting Plate
03	1	61-2229A			Window Glass	33*	1	61-1321			Mounting Plate
04	1	66-0304	1		O-Ring, Fluoroelast. #127	34	1	61-9429			Screw, 10-32x3/16 with O-ring
05	1	61-2413			Drain Plug	36	1	61-2221A			Intake Nipple
06	1	61-2158A			O-Ring, Fluoroelast. #111	37	3	2-00-6708			Screw, Sockethead, #10-32x1/2
07	1	61-2230B			Oil Case	38	1	61-2313			Adapter Plate for Franklin Motor
08	1	61-2130A	1		O-Ring, Fluoroelast. #115	38	1	61-2314			Adapter Plate for Emerson Motor
09	1	61-2372			Filler Plug	39	2	4-21-5010			Dowel Pin, 3/16"x5/8"
10	8	2-00-6712			Screw, Sockethead, #10-32x3/4	40	2	41-2693			Coupling Body
11	14	2-62-0793			Lock Washer #10	41	4	2-00-6716			Screw, Sockethead, #10-32x1
12	3	62-0003			Screw, Sockethead, #10-32x3	42	1	41-2694		1	Coupling Rubber
13	1	61-1189B			End Plate	43	1	61-2377			Handle
14	1	61-1186B			Cover Baffle	44	2	2-61-1165			Washer 1/4
15	1	61-0007A			Exhaust Rotor Set	45	2	2-01-6112			Screw, Sockethead, 1/4-20x3/4
16	4	4-21-3006			Dowel Pin 1/8x3/8	46	1	61-9479A		1	Drip Pad
17	1	61-1182C			Gerotor Housing	47	1	61-2039C			Motor Assy 1/4 HP, 60Hz, Franklin
18	2	2-10-1604			Screw, Binderhead, #8-32x1/4	47	1	61-2040C			Motor Assy 1/4 HP, 50Hz, Franklin
19	2	2-68-5632			Washer #8	47	1	61-2007C			Motor Assy 1/4 HP, 60Hz, Emerson
20	1	61-1120A			Thrust Disk	47	1	61-2025C			Motor Assy 1/4 HP, 50Hz, Emerson
21	1	61-9398A			Valve Cover Spacer	48	4	61-2123A		4	Rubber Bumper
22	2	61-1121A			Key	49	1	61-2120C			Pump Base
23	1	61-1123A	1		Intake Valve	50	4	2-00-6812			Screw, Sockethead, #10-32x5/8
24	1	61-1128A	2		Backer Valve	53*	1	61-2139A			Disk Assembly, Isolator Valve
25	1	61-1124B			Shaft	54*	1	61-2216A			Plunger
26	1	61-0006A			Intake Rotor Set	55*	1	61-2155A		1	O-Ring, Fluoroelast. #020
27	1	2-10-5607			Screw, Roundhead, #8-32x7/16	56*	1	61-2212A			Adapter, Isolator Valve
28	1	61-1179A	1		O-Ring, Fluoroelast. #034	57*	2	2-00-6410			Screw, Sockethead, #6-32x5/8
29	1	41-2962	1		Lip Seal, 3/8"	58*	1	61-2308			ISO Operator Assembly w/O-Ring
31	1	61-1184C			Wear Plate	**	1	1417			Exhaust Filter

A*: MAJOR REPAIR KIT CAT # N/A
 B*: MINOR REPAIR KIT CAT # 8890K-02
 * Parts used in 8890A-55 Pump only
 ** Part supplied with the Pump but not shown

Section 5: OPERATION

5.1 Starting Procedure

Before using the pump for the first time, it is a good idea to spend a few minutes inspecting the pump and its electrical and vacuum connections. Review Section 1 – Installation as required. Check the AZ power outlet to be sure that it is the same voltage and phase as the pump motor. Connect the pump's power cord to the power outlet. Check the pump's oil level to be sure it is correct.

Close off the pump intake and run the pump at blankoff for a few minutes. The gurgling noise should go away after a few seconds of running; it is caused by the high volume of air that flows through the pump is first turned on. If the gurgling noise does not stop, check the oil level to see if it is low, and check the pump intake fitting to be sure that it is tight. Once proper pump operation has been verified, the pump intake can be opened to the vacuum system.

After running the pump for a few minutes, check the oil level again. If the level is too high or too low, stop the pump and add or remove oil as needed. Stop the pump and vent it to the atmosphere before adjusting the pump fluid level.

Before starting the pump when connected to the vacuum system, check all vacuum connections.

5.2 High Pressure Operation

The Model 8890 pump is designed to be most efficient when operated at or near its ultimate blankoff pressure. When operated at elevated pressures, the exhaust filter provided should be used. When operated at high pressures for long periods of time, this filter will saturate quickly, and puffs of “smoke” will be seen around it. Replace the filter with a new one, or replace with the Model 1417 Filter with replaceable cartridge. See Section 10 – Accessories.

5.3 Shutdown Procedures

A few simple precautions are necessary before performing a pump shutdown. If a gauge is connected to the system, first isolate the gauge, then turn off the power to the pump and open the system to the atmosphere.

NOTE

The intake isolation valve, in models equipped with this feature, will automatically close when power to the pump is turned off. This will maintain vacuum in the system (if the pump remains connected to the rest of the system) and will vent the pump to atmosphere.

If the pump is disconnected from the system for any length of time, cover the pump intake with a rubber stopper or other suitable cover to protect the pump against contamination and loose particles. If the exhaust port is open, that should be covered also. If the pump oil is contaminated and the pump is going to be stored for a prolonged period, the oil should be changed before the pump is stored. Even if a pump is stored for a long period with oil initially in good condition, check the oil when the pump is restarted, and change the oil if necessary.

Section 6: MAINTENANCE AND TROUBLESHOOTING

6.1 Vacuum Problems

Inability to attain sufficient vacuum in a system is usually due to leakage, contamination, or unusual outgassing. A system must be thoroughly clean and free from leaks to operate efficiently. If the system is found to be clean and leak-free, but vacuum problems still exist, the pump should be checked. A simple way to test the pump is to measure its ultimate pressure capability. This can be done by disconnecting the pump from the rest of the system and connecting a pressure gauge directly to the pump intake. (Be sure to seal the pump intake from the atmosphere.) The gauge can be any type that is suitable for the pressure levels expected. Run the pump until the gauge indicates no further reduction in pressure, and compare the pressure reading to the pump's ultimate pressure rating.

If the pump meets its ultimate pressure specifications only when disconnected from the rest of the system, the fault must be elsewhere in the system. If the pump's ultimate pressure is unusually high, the pump may be badly contaminated, low on oil, or mechanically defective. However, if the pressure is only slightly higher than the pump's guaranteed pressure, an oil change may be all that is needed to bring performance up to specifications. Be sure to use only DIRECTORR® Premium Oil in the Model 8905 Vacuum Pump; the ultimate pressure guarantee does not apply if other types of oil are used.

The most common cause of efficiency loss in a vacuum pump is contamination of the oil, which is usually caused by foreign particles and/or condensed vapors. The condensate emulsifies with the oil, and when the oil is recirculated, the condensate evaporates. The resulting vapor then reduces the ultimate vacuum attainable in the system.

Some foreign particles and vapors from sludges with the oil. The presence of sludge in the oil impair its sealing and lubricating properties, and eventually could cause pump seizure. Therefore, periodic oil changes are necessary to maintain efficient operation of the system. The interval at which oil changes are required is different for each system; experience will help you determine the proper interval for your system and process.

6.2 Oil Change

The best time to change the oil is when the pump is warm and the oil is less viscous. Before attempting an oil change, the pump must be disconnected from the power outlet.



WARNING

The drain oil is hot and can cause burns. Operating temperature of the oil is typically 140 degrees Fahrenheit or higher. Avoid skin contact with the oil.

Oil Removal: Drain the oil into a container by removing the black plastic drain plug located below and to the left of the oil sight glass. The container should hold at least one quart of oil. The pump may be tilted to remove residual oil out of the oil reservoir.

Oil fill: Replace the oil drain plug, remove the black plastic oil fill plug located on the top of the oil reservoir. Fill the pump with vacuum oil until the level reaches the Full mark as seen from the oil sight glass. Do not overfill the pump. The excess oil tends to splash out of the exhaust. Replace the oil fill plug. Check the oil level again after the pump warms up to its normal operating temperature. Add or remove oil as needed. It is normal for the oil level to change upon initial start up.

NOTE

When filling the pump with oil, be sure to use only DIRECTORR® Premium Oil. The ultimate pressure guarantee applies only if this oil is used.

6.3 Shaft Seal Replacement

When the shaft seal in the mounting plate shows signs of excessive oil leakage, it should be replaced. Before attempting replacement of the seal, the pump must be disconnected from the vacuum system and from the power outlet. New lip seal (P/N 41-2962) and new gasket (61-1119B) or seal replacement kit (Cat. No. 8890K-03) should be available before attempting repair.

1. **Drain Oil** by opening the drain plug. The pump may be tilted to remove residual oil out of the oil case.
2. **Separate Base** from the pump by removing four socket head screws 10-32 x 5/8.
3. **Separate the Pump from the Motor Assembly** by removing four socket head screws 10-32x1 from the motor adapter plate. For 8890A-55, the isolator valve coil should be slipped off by removing nut, name plate and large washer from valve projecting from the inside of the mounting plate. Set aside the motor assembly with isolator coil placed next to it.
4. **Remove Oil Case** from the pump by placing it on its mounting plate side and unscrew four socket head screws 10-32x3/4.
5. **Remove Coupling** from the pump shaft by loosening the setscrew. Separate pump module from the mounting plate by unscrewing three socket head screws 10-32x1/2 and three split lock washers. Discard the gasket.
6. **Push out Lip Seal** out of the wear plate with a blunt edge of a screw-driver blade. Discard the lip seal. Older models will have lip seal installed in the mounting plate.
7. **Install New Shaft Seal** with flat side of the seal toward the motor. Use a little oil on the lip seal outside periphery. The seal is located 0.09 from the coupling end inside the bore. Seal assembly tool 61-2172A used to install it.
8. **Place the Pump Module** on a table with shaft up. Slide shaft insertion tool 61-2170A over the shaft end and place the new gasket over the modular assembly.
9. **Moisten the Lip Seal**, shaft and the tool with oil prior to the assembly. Slip the mounting plate over the shaft of the modular pump.
10. **Adjust Gasket** in proper angular location and then tighten gradually 3 screws 10-32x1/2 with lock washers.
11. **Assemble Coupling Body** to pump shaft all the way to the shaft shoulder and tighten the setscrew.
12. **Attach Oil Case** to the mounting plate using four socket head screws 10-32x3/4 with 4 lock washers. Tighten screws gradually.
13. Insert two dowel pins to the mounting plate and put the coupling spider in place.
14. **Attach Motor Assembly** to the mounting plate using four socket head screws 10-32x1 with lock washers. For Model 8890A-55, watch for wires from the isolator valve coil to be placed in groove of motor adapter plate during assembly. After carefully fitting all parts together cross tighten the four screws gradually, then attach the coil to the isolator valve mechanism by first slipping on the coil houlder and then the coil with name plate. Tighten the coil nut (name plate should turn freely).
15. Attach Base to the mounting plate by means of four socket head screws 10-32x5/8 long.
16. Finally pump is filled with **DIRECTORR® Premium Oil** and is ready to be inspected for its performance.

TROUBLESHOOTING

6.4 Trouble Shooting Guide

Table 6.1 Troubleshooting Guide for the Model 8890 Vacuum Pump

CONDITION	PROBABLE CAUSE	RECOMMENDED CORRECTIVE ACTION
Pump will not start	<ol style="list-style-type: none"> 1. Power off 2. Coupling damaged (8804) or coupling set-screw loose 3. Room is too cold 4. Pump mechanism is seized 	<p>Check switches and fuses. Check coupling.</p> <p>Drain and refill pump with warm DIRECTORR® Premium Oil. Try to start with intake open to atmosphere Pump to be repaired.</p>
Pump does not reach ultimate pressure	<ol style="list-style-type: none"> 1. Pump oil is contaminated. 2. Pump is not filled with oil, or has low oil level 3. Pump has wrong oil in it. 4. Leak in vacuum system. 5. Dirty foreline trap. 	<p>Flush and change pump oil. Use a foreline trap. Add recommended pump oil.</p> <p>Flush and refill with recommended oil. Locate and eliminate leak source. Clean out cold traps and replacement elements in coaxial and molecular sieve traps.</p>
Excessively noisy pump.	<ol style="list-style-type: none"> 1. Intake or exhaust lines are restricted. 2. Coupling damaged (8804). 3. Inside mechanism damaged 	<p>Clear and straighten out lines Check oil level. Examine coupling/replace. Pump to be repaired.</p>
Pump generates excessive smoke or oil mist from exhaust port.	<ol style="list-style-type: none"> 1. Pump overfilled with oil 2. Pump operating continuously above its maximum operating pressure 3. Exhaust filter is saturated with oil 	<p>Drain excess pump oil Use a larger capacity pump or modify your vacuum system.</p> <p>Replace filter element using 1417L element.</p>
Pump oil is dark has an unusual color, or is dirty.	<ol style="list-style-type: none"> 1. Pump oil contaminated by process gases, or other foreign material ingested by pump 2. Pump oil has degraded. 	<p>Flush and change oil. Use a foreline trap in future. Consider using an oil filtration system or inert pump oils</p> <p>Pump was run too low on oil. The recommended oil was not used.</p>
Pump does not achieve its rated pumping speed	<ol style="list-style-type: none"> 1. Pump is running too cold. 2. Exhaust or intake line is too narrow. 3. Pump oil is contaminated. 4. Very dirty intake line. 	<p>Allow pump to run until it warms up to its operating temperature. Install larger inner diameter tubing.</p> <p>Flush and change pump oil. Use a foreline trap in future. Clean or replace vacuum piping.</p>

Section 7: REPAIR SERVICE

7.1 Repair Kits

Minor repairs to the pump can usually be performed in the field. Minor repair kits contain those parts which can be easily replaced, are most likely to wear, and involve only minor repair. Parts constituting the internal mechanism of the pump which would require complete pump disassembly for replacement are not included.

7.2 Major Factory Repair

With proper care, this pump will give many years of service. The basic working parts of vacuum pumps are machined to close tolerances and require assembly on fixtures, with special tools, by mechanics who are highly skilled at this work. Should major repairs involving the pump mechanism become necessary, we strongly recommend that the pump be returned to the factory for repair.

Welch Rietschle Thomas maintains complete repair facilities in the United States. These facilities are well equipped and staffed with experts to insure prompt reconditioning of all returned pumps. Broken, worn, scored or corroded parts are replaced with new parts, and the pump is thoroughly evaluated and tested to determine that it meets the performance requirements.

7.3 Minor Repair Kit For Model 8890 Vacuum Pumps

A minor repair kit, Cat. No. 8890K-02, is available for the Model 8890 Vacuum Pump. This kit contains a group of parts that can be replaced in the field. Table 7-1 lists the contents of the minor repair kit. Refer to Figure 4-1 Exploded View Diagram. This should be used as a guide for disassembly and assembly.

Table 7.1 Minor Repair Kit for Model 8890 Vacuum Pump, Parts List

Part No.	Description	Quantity	Where Used
61-2158A	O-Ring, #110	1	Oil Drain Plug
61-1123A	Intake Valve	1	Pump Module
61-1128A	Backer Valve	2	Pump Module
61-1122A	Exhaust Valve	1	Older Models
61-1178A	Silencer	1	Older Models
61-1119B	Oil Case Gasket	1	Mounting Plate
61-2130A	Bumper Rubber	4	Base
41-2694	Coupling Spider	1	Motor/Pump
41-2962	Lip Seal	1	Wear Plate
61-2130A	O-Ring, #115	1	Oil Fill & Intake Older Models
61-2162A	O-Ring, #015 (iso. valve models)	1	Isolation Valve
61-2155A	O-Ring, #020 (iso. valve models)	1	Isolation Valve
67-0729	Instruction Manual	1	—
61-1174A	Installation Tool	1	Lip Seal
61-1175A	Insertion Tool	1	Lip Seal
61-2231	Tetraseal, #127 (New S/N 1025 & Up)	1	Sight Glass Window
61-1179A	O-ring, #034	1	Gas Ballast
61-9479A	Drip Pad	1	Pump

Section 8: ACCESSORIES

DIRECTORR® Premium Vacuum Pump Oil is the oil furnished with each new pump. The vacuum guarantee for this pump applies only when the recommended oil is used. Use of other types of oil in this pump can cause inferior performance, both in pumping speed and ultimate vacuum attained, and may eventually cause permanent pump damage. The oil is available in the sizes listed below.

Ordering Information for DIRECTORR® Premium Oil

Cat. No.	Container Size	Quantity	Cat. No.	Container Size	Quantity
8995P-11	1 Liter	1 Each	8995P-20	5 Gallon	1 Each
8995P-15	1 Gallon	1 Each	8995P-25	55 Gallon	1 Each

DIRECTORR® Gold Vacuum Pump Oil is also available. It is a specially formulated mineral oil for direct-drive pumps. It has an exceptionally low oil vapor, which results in a lower ultimate total pressure, less backstreaming and faster system pumpdown. It is resistant to oil breakdown, especially at high temperatures. As a result less frequent oil changes are required. The pump will give better vacuum stability over long periods of time. This oil can be used in mildly corrosive applications in direct-drive pumps where a hydrocarbon oil is not recommended.

Ordering Information for DIRECTORR® Gold Oil

Cat. No.	Container Size	Quantity	Cat. No.	Container Size	Quantity
8995G-11	1 Liter	1 Each	8995G-20	5 Gallon	1 Each
8995G-15	1 Gallon	1 Each	8995G-25	55 Gallon	1 Each

Exhaust Filters

One 1417 Exhaust Filter is furnished with each pump.

Ordering Information for Exhaust Filters

Cat. No.	Description
1417	Exhaust Filter, Standard (Cat. No. 1417L Replacement Element)
1417B	Exhaust Filter with oil return line (use when operating pump continuously at 1 Torr or above)

Coaxial Trap

A coaxial trap with ISO NW 16 flange fittings is available to reduce oil backstreaming. The trap is constructed entirely of 304 stainless steel, and has a two-piece clamped body design to allow easy element replacement. Three different types of replaceable elements are available for the trap. Requires an ISO NW 16 to Hose Nipple Adapter Kit, Cat. No. 1419H-16.

Ordering Information for Coaxial Trap

Cat. No.	Description
541001	Coaxial Trap (requires an element--see below)
541911	Copper Element for Coaxial Trap
541921	Stainless Steel Element for Coaxial Trap

Vacuum Gauge

This solid-state gauge, Cat. No. 1515, provides an accurate and inexpensive means of measuring vacuum levels from 0 to 5000 millitorr. The gauge is portable, and is supplied with one permanently-attached probe cable, one gauge tube, and a carrying handle. This gauge should NOT be used to measure the pressure of flammable or explosive gases or vapors. The gauge operates on 110/115 volts AC, 50/60 Hz.

Ordering Information for Vacuum Gauge

Cat. No.	Description
1515	Vacuum Gauge, Thermocouple, Single Station
1515A	Replacement Gauge Tube
506111	Female 1/8 in. NPT to ISO NW 16 Flange

Molecular Sieve Trap

A molecular sieve trap with ISO NW 16 flange fittings is available to both reduce oil backstreaming and to remove trace amounts of water vapor. Sieve charge can be regenerated using a built-in heater. Two different types of sieve charges are available for the trap. Requires an ISO NW 16 to Hose Nipple Adapter Kit, Cat. No. 1419H-16.

Ordering Information for Molecular Sieve Trap

Cat. No.	Description
543001	Molecular Sieve Trap, ISO NW 16 (requires a sieve charge - see below.)
543950	Synthetic Zeolite
543960	Activated Alumina

Dry-Ice Cold Trap

A dry ice cold trap is a convenient low cost way to trap excess condensable vapors that could enter the vacuum pump. Dry ice and alcohol slurry (do not use acetone) is placed in the removable 3 quart center well. Slurry will stay cold for up to 12 hours depending on vapor load. Trapping surface is visible during operation.

Ordering Information for Dry-Ice Cold Trap

Cat. No.	Description
1420H-14	Dry-Ice Cold Trap, 1/2 in. Inlet and Outlet

ISO NW 16 Fittings and Adapters

Various fittings and adapters for use with ISO NW 16 connectors are available.

Ordering Information for ISO NW 16 Fittings and Adapters

Catalog No.	Description
1419H-16	Hose Adapter Kit, ISO NW 16 (includes hose nipple adapter, centering ring assembly and hinged clamp)
302201	Hinged Clamp, ISO NW 16
303101	Centering Ring Assembly, ISO NW 16

MATERIAL SAFETY DATA SHEET

Welch 8995P Series DIRECTORR® Premium Vacuum Pump Oil MSDS Welch P/N 67-0278A, Revision 4

HMIS Rating: Health: 0 Flammability: 1 Reactivity: 0 Special: X

SECTION 1 - IDENTIFICATION

Chemical Name: Severely Hydrotreated Paraffinic Oil

Synonyms: DIRECTORR® 8995P Premium Vacuum Pump Oil

Formula: NA (Product is refined naturally occurring mixture)

CAS No./DOT Classification: 72623-87-1 (60%)
72623-85-9 (40%)

Manufacturer's Name: Welch Vacuum Technology, Inc.
7300 North Linder Ave. P.O. 183
Skokie, IL 60076-0183

Date Prepared: January 1, 2000

Telephone Number for
General Information: (847) 676-8800

SECTION 2 - HAZARDOUS INGREDIENTS/IDENTITY

Component	OSHA PEL	Exposure Limits in Air	
		ACGIH TVL	Other Limits Recommended %(Optional)
Severely Hydrotreated 100% Paraffinic Oil	NO	NO	————

To the best of our knowledge, the above listed component is not hazardous according to OSHA (1910.1200) or one or more state right-to-know lists.

SECTION 3 - PHYSICAL AND CHEMICAL CHARACTERISTICS

Boiling Point: 445°F (ASTM D-86 Method) Vapor Pressure, mm Hg: 3×10^{-6} @ 25°C

Melting Point: N/A Vapor Density (Air = 1): N/D

Specific Gravity (Water = 1): 0.87 @ 22°C (72°F) Water Solubility: NIL

Evaporation Rate (butyl acetate = 1): N/D

Appearance and Odor: Clear and Odorless

FIRST AID MEASURES

If Inhaled:	Remove to fresh air. If victim has stopped breathing, give artificial respiration. Seek medical attention.
In Case of Eye Contact:	Immediately flush eyes with plenty of cool water for 15 minutes. Do not let victim rub eyes.
In Case of Skin Contact:	Wash affected area thoroughly.
If Swallowed:	Do not induce vomiting. If victim is conscious and able to swallow, give water to dilute, do not give sodium bicarbonate, fruit juices, or vinegar. See medical attention.

SECTION 7 - PRECAUTIONS FOR SAFE HANDLING AND USE

Storage and Handling Precautions:	No special precautions necessary.
Waste Disposal Method:	Under RCRA, it is the responsibility to the user of products to determine at the time of disposal whether product meets RCRA criteria for hazardous waste. This is because product uses, transformations, mixture, processes, etc. may render the resulting material hazardous.
Action to Take for Spills or Leaks:	Wear appropriate respiratory protection and protective clothing as described below. Contain spilled material. Transfer to secured containers. Collect using absorbent media. In the event of an uncontrolled release of this material, user should determine if release is reportable under applicable laws and regulations under RCRA.

SECTION 8 - CONTROL MEASURES

Ventilation:	Normal.
Respiratory Protection:	Respirators should be selected based on the form and concentration of contaminant in the air and in accordance with OSHA (1910.134).
Eye Protection:	Safety goggles meeting ANSI Z 87.2 Standard.
Protective Clothing:	Impervious gloves when prolonged contact cannot be avoided.
Other Protective Measures:	Wear impervious clothing for the duration of anticipated exposure.
Work/Hygienic Practices:	Employees should exercise reasonable personal cleanliness.

All statements, information, and data provided in this Material Safety Data Sheet are believed to be accurate and reliable, but are presented without guarantee, warranty, or responsibility of any kind, expressed or implied on our part. Users should make their own investigations to determine the suitability of the information of products for their particular purpose.

ATTENTION: Misuse of empty containers can be hazardous. Empty containers can be hazardous if used to store toxic, flammable or reactive materials. Cutting or welding of empty containers might cause fire, explosion, or toxic fumes from residues. Do not pressurize or expose to open flame or heat. Keep containers closed and drum bung in place.

